



Replaceable SSQ/SST with Integral Clips

SSQCD0303



These fuse/clip assemblies can efficiently placed in a single pass. Once reflowed, fuse replacement requires no resoldering.

Electrical Specifications

Maximum Recommended Fuse Current Rating 8 Amperes, 125 Volts.

Environmental Specifications

Soldering Techniques & Compatibility

Reflow: Industrial standard: 240°C peak

Operating Temperature

-55°C to 125°C

Shock

MIL-STD-202, Method 213, Test Condition I
(100 G's peak for 6 milliseconds).

Vibration

MIL-STD-202, Method 201
(10-55 Hz, 0.06 inch, total excursion).

Insulation Resistance

MIL-STD-202, Method 302, Test Condition A
(After Opening) 10,000 ohms minimum.

Solderability

MIL-STD-202, Method 208

Thermal Shock

MIL-STD-202, Method 107, Test Condition B
(-65°C to +125°C)

Physical Specification

Materials

Clip Terminals: Tin Plated Inconel Alloy

Packaging

2,000 fuses in 13 inches dia. reel, 16mm wide tape, 8mm pitch, per EIA standard 481

SSQ Square Ceramic Surface Mount Quick Action Fuse	
Catalog Number	Ampere Rating
SSQC 250	250mA
SSQC 375	375mA
SSQC 500	500mA
SSQC 750	750mA
SSQC 1	1A
SSQC 1.25	1.25A
SSQC 1.5	1.5A
SSQC 2	2A
SSQC 2.5	2.5A
SSQC 3	3A
SSQC 3.5	3.5A
SSQC 4	4A
SSQC 5	5A
SSQC 6.3	6.3A
SSQC 7	7A
SSQC 8	8A

SST Square Ceramic Surface Mount Slow Blow Fuse	
Catalog Number	Ampere Rating
SSTC 375	375mA
SSTC 500	500mA
SSTC 625	625mA
SSTC 750	750mA
SSTC 1	1A
SSTC 1.5	1.5A
SSTC 2	2A
SSTC 2.5	2.5A
SSTC 3	3A
SSTC 3.5	3.5A
SSTC 4	4A
SSTC 5	5A
SSTC 7	7A

Consult manufacturer for other ratings

Mechanical Dimensions

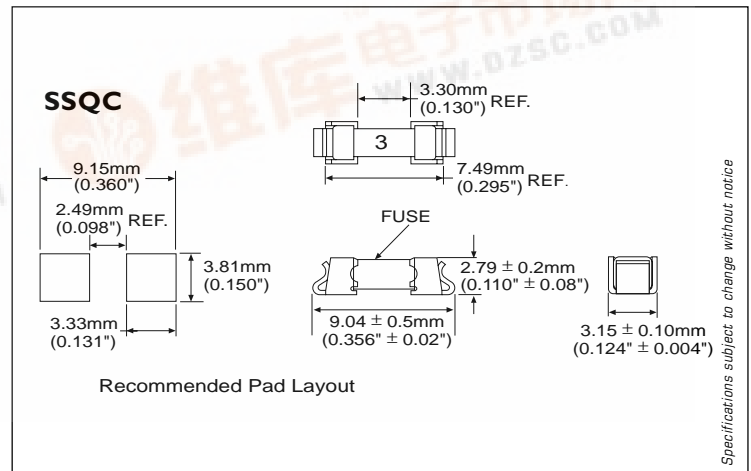

Specifications subject to change without notice

ORDERING INFORMATION SEE PAGES 67 & 68



SMD Comparison

FUSE TYPE	MECHANICAL DIMENSIONS	PAD LAYOUT RECOMMENDED
SMP		
SSQ / SST		
SSQ / SST WITH INTEGRAL CLIP		
CIQ		
C2Q		

Specifications subject to change without notice

NOTE - see important information under "User Guide" on P.08

Corporate Office
Bel Fuse Inc.
 206 Van Vorst Street, Jersey City, NJ 07302
 Tel: 201-432-0463
 Fax: 201-432-9542
 E-Mail: belfuse@belfuse.com
 Website: www.belfuse.com

Far East Office
Bel Fuse Ltd.
 8F/8 Luk Hop Street
 San Po Kong
 Kowloon, Hong Kong
 Tel: 852-2328-5515
 Fax: 852-2352-3706

European Office
Bel Fuse Europe Ltd.
 Preston Technology Management Centre
 Marsh Lane, Preston PR1 8UD
 Lancashire, U.K
 Tel: 44-1772-556601
 Fax: 44-1772-888366