

PROTECTION PRODUCTS

Description

RailClamps are surge rated diode arrays designed to protect high speed data interfaces. The SR series has been specifically designed to protect sensitive components which are connected to data and transmission lines from overvoltage caused by **ESD** (electrostatic discharge), **EFT** (electrical fast transients), and **lightning**.

The unique design of the SRV08-4 integrates eight surge rated, low capacitance steering diodes with a TVS diode in a SOT23- 6L package. During transient conditions, the steering diodes direct the transient to either the positive side of the power supply line or to ground. The internal TVS diode prevents over-voltage on the power line, protecting any downstream components.

The low capacitance array configuration allows the user to protect four high-speed data or transmission lines. The low inductance construction minimizes voltage overshoot during high current surges.

Features

- ◆ ESD protection to **IEC 61000-4-2, Level 4**
- ◆ Array of surge rated diodes with internal TVS Diode
- ◆ Small package saves board space
- ◆ Protects four I/O lines
- ◆ Low capacitance (**<5pF**) for high-speed interfaces
- ◆ Low clamping voltage
- ◆ Low operating voltage: 5.0V
- ◆ Solid-state silicon-avalanche technology

Mechanical Characteristics

- ◆ JEDEC SOT-23 6L package
- ◆ Molding compound flammability rating: UL 94V-0
- ◆ Marking : V08
- ◆ Packaging : Tape and Reel per EIA 481

Applications

- ◆ USB Ports
- ◆ Video Graphics Cards
- ◆ Monitors and Flat Panel Displays
- ◆ Digital Video Interface (DVI)
- ◆ Cellular Handsets
- ◆ Notebook Computers
- ◆ Portable Electronics
- ◆ Microcontroller Input Protection

Circuit Diagram

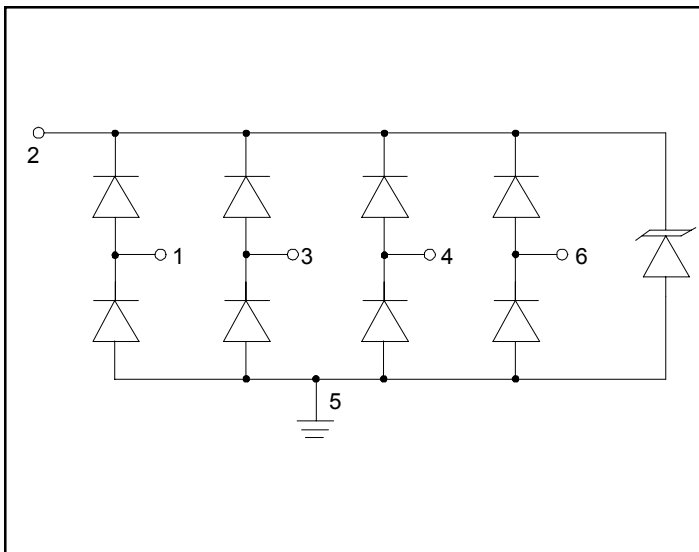

Schematic & PIN Configuration

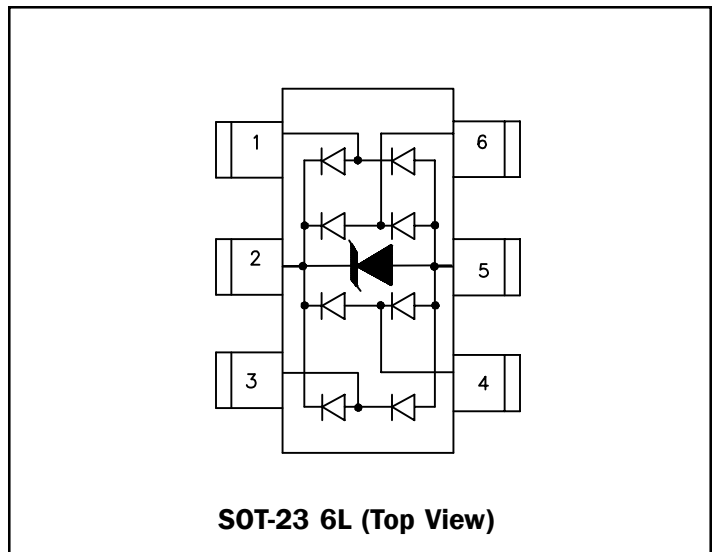

PROTECTION PRODUCTS
Absolute Maximum Rating

Rating	Symbol	Value	Units
Peak Pulse Power (tp = 8/20μs)	P_{pk}	150	Watts
Peak Pulse Current (tp = 8/20μs)	I_{pp}	6	A
Continuous Forward Current	I_F	200	mA
ESD per IEC 61000-4-2 (Air) ESD per IEC 61000-4-2 (Contact)	V_{ESD}	15 8	kV
Lead Soldering Temperature	T_L	260 (10 sec.)	°C
Operating Temperature	T_J	-55 to +125	°C
Storage Temperature	T_{STG}	-55 to +150	°C

Electrical Characteristics (T=25°C)

SRV08-4						
Parameter	Symbol	Conditions	Minimum	Typical	Maximum	Units
Reverse Stand-Off Voltage	V_{RWM}	Pin 2 to 5			5	V
Reverse Breakdown Voltage	V_{BR}	$I_t = 1mA$ Pin 2 to 5	6			V
Reverse Leakage Current	I_R	$V_{RWM} = 5V, T=25°C$ Pin 2 to 5			5	μA
Forward Voltage	V_f	$I_f = 15mA$			1.2	V
Clamping Voltage	V_C	$I_{pp} = 1A, tp = 8/20μs$ Any I/O pin to Ground			12.5	V
Clamping Voltage	V_C	$I_{pp} = 5A, tp = 8/20μs$ Any I/O pin to Ground			17.5	V
Junction Capacitance	C_j	$V_R = 0V, f = 1MHz$ Any I/O pin to Ground		3	5	pF
		$V_R = 0V, f = 1MHz$ Between I/O pins		1		pF

PROTECTION PRODUCTS

Typical Characteristics

Non-Repetitive Peak Forward Current vs. Pulse Time

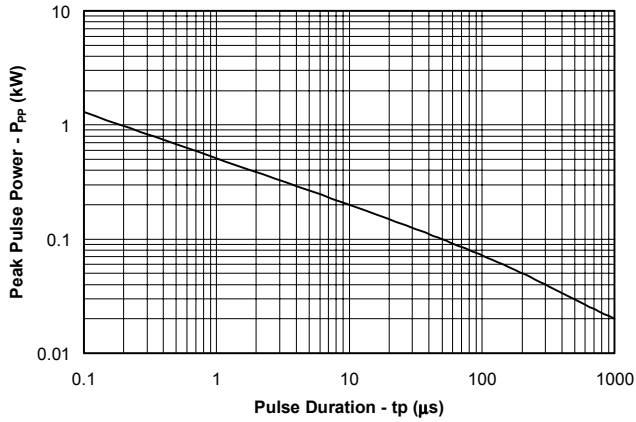

Power Derating Curve

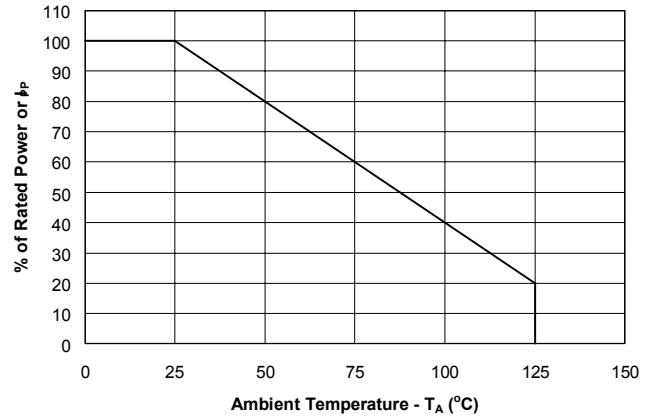

Pulse Waveform

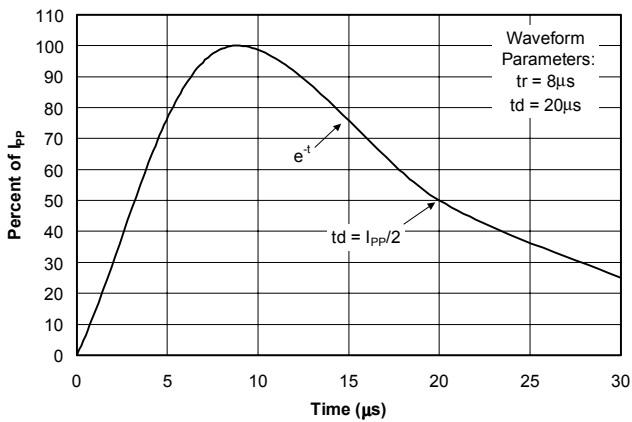

Forward Clamping Voltage vs. Peak Pulse Current Current

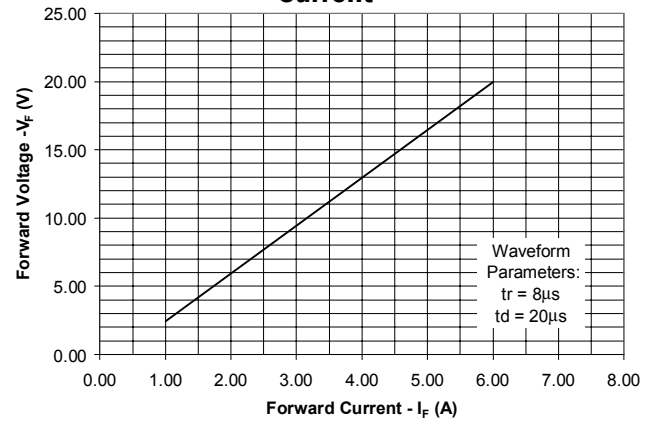

Variation of Capacitance vs. Reverse Voltage

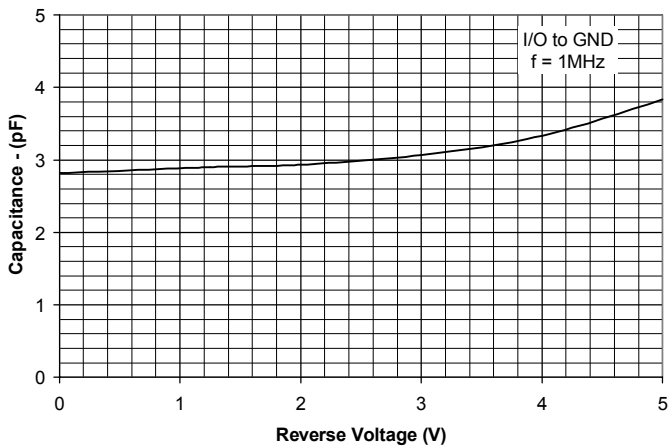

Insertion Loss S21

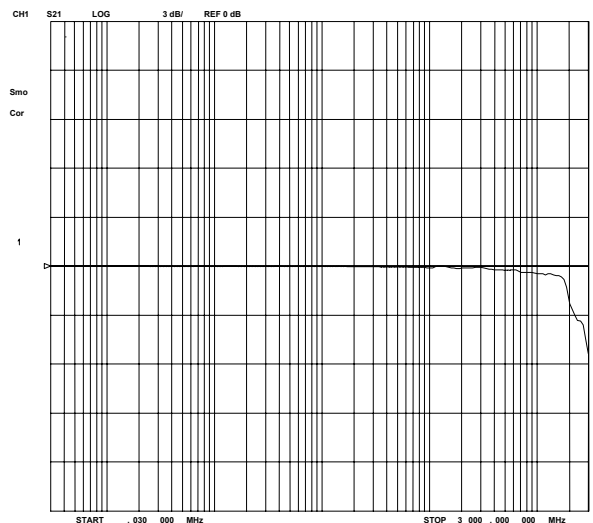

PROTECTION PRODUCTS

Applications Information

Device Connection Options for Protection of Four High-Speed Data Lines

The SRV08-4 TVS is designed to protect four data lines from transient over-voltages by clamping them to a fixed reference. When the voltage on the protected line exceeds the reference voltage (plus diode V_F) the steering diodes are forward biased, conducting the transient current away from the sensitive circuitry. Data lines are connected at pins 1, 3, 4 and 6. The negative reference is connected at pin 5. This pin should be connected directly to a ground plane on the board for best results. The path length is kept as short as possible to minimize parasitic inductance. The positive reference is connected at pin 2. In this configuration the data lines are referenced to the supply voltage.

Figure 1 - Data Line and Power Supply Protection Using Vcc as reference

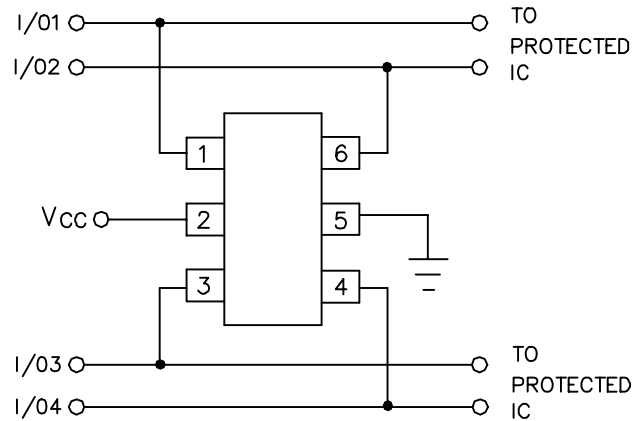

Video Interface Protection

Video interfaces are susceptible to transient voltages resulting from electrostatic discharge (ESD) and “hot plugging” cables. If left unprotected, the video interface IC may be damaged or even destroyed. Protecting a high-speed video port presents some unique challenges. First, any added protection device must have extremely low capacitance and low leakage current so that the integrity of the video signal is not compromised. Second, the protection component must be able to absorb high voltage transients without damage or degradation. As a minimum, the device should be rated to handle ESD voltages per IEC 61000-4-2, level 4 (15kV air, 8kV contact). The clamping voltage of the device (when conducting high current ESD pulses) must be sufficiently low enough to protect the sensitive CMOS IC. If the clamping voltage is too high, the “protected” device may latch-up or be destroyed. Finally, the device must take up a relatively small amount of board space, particularly in portable applications such as notebooks and handhelds. The SRV08-4 is designed to meet or exceed all of the above criteria. A typical video interface protection circuit is shown in Figure 2. All exposed lines are protected including R, G, B, H-Sync, V-Sync, and the ID lines for plug and play monitors.

Figure 2 - Video Interface Protection

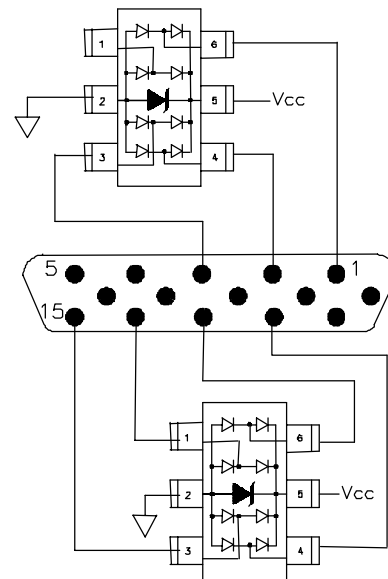

ESD Protection With RailClamps

RailClamps are optimized for ESD protection using the rail-to-rail topology. Along with good board layout,

PROTECTION PRODUCTS

Applications Information (continued)

these devices virtually eliminate the disadvantages of using discrete components to implement this topology. Consider the situation shown in Figure 3 where discrete diodes or diode arrays are configured for rail-to-rail protection on a high speed line. During positive duration ESD events, the top diode will be forward biased when the voltage on the protected line exceeds the reference voltage plus the V_F drop of the diode. For negative events, the bottom diode will be biased when the voltage exceeds the V_F of the diode. At first approximation, the clamping voltage due to the characteristics of the protection diodes is given by:

$$V_C = V_{CC} + V_F \quad (\text{for positive duration pulses})$$

$$V_C = -V_F \quad (\text{for negative duration pulses})$$

However, for fast rise time transient events, the effects of parasitic inductance must also be considered as shown in Figure 4. Therefore, the actual clamping voltage seen by the protected circuit will be:

$$V_C = V_{CC} + V_F + L_P di_{ESD}/dt \quad (\text{for positive duration pulses})$$

$$V_C = -V_F - L_G di_{ESD}/dt \quad (\text{for negative duration pulses})$$

ESD current reaches a peak amplitude of 30A in 1ns for a level 4 ESD contact discharge per IEC 61000-4-2. Therefore, the voltage overshoot due to 1nH of series inductance is:

$$V = L_P di_{ESD}/dt = 1 \times 10^{-9} (30 / 1 \times 10^{-9}) = 30V$$

Example:

Consider a $V_{CC} = 5V$, a typical V_F of 30V (at 30A) for the steering diode and a series trace inductance of 10nH. The clamping voltage seen by the protected IC for a positive 8kV (30A) ESD pulse will be:

$$V_C = 5V + 30V + (10nH \times 30V/nH) = 335V$$

Note that it is not uncommon for the V_F of discrete diodes to exceed the damage threshold of the protected IC. This is due to the relatively small junction area of typical discrete components. It is also possible that the power dissipation capability of the discrete diode will be exceeded, thus destroying the device.

The RailClamp is designed to overcome the inherent disadvantages of using discrete signal diodes for ESD suppression.

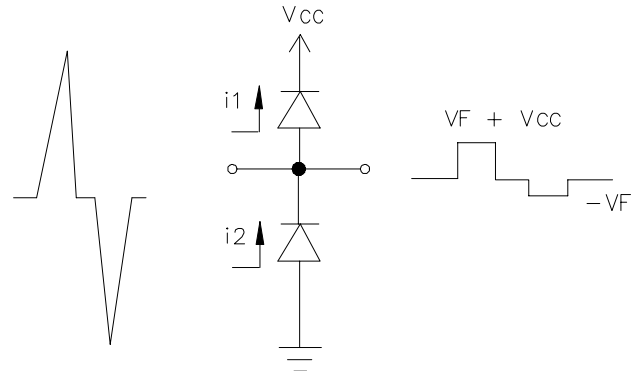

Figure 3 - "Rail-To-Rail" Protection Topology (First Approximation)

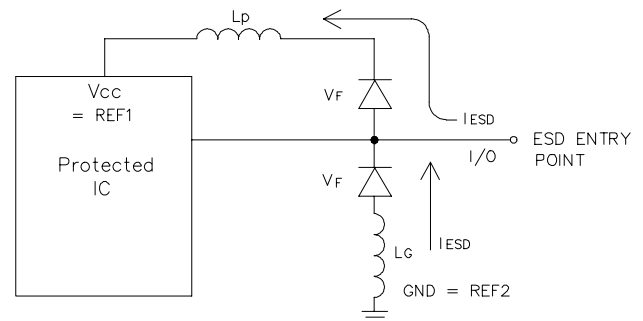

Figure 4 - The Effects of Parasitic Inductance When Using Discrete Components to Implement Rail-To-Rail Protection

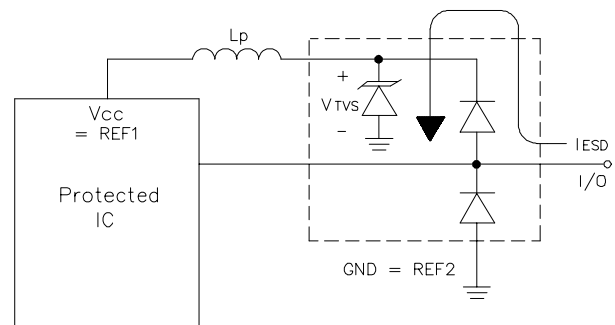
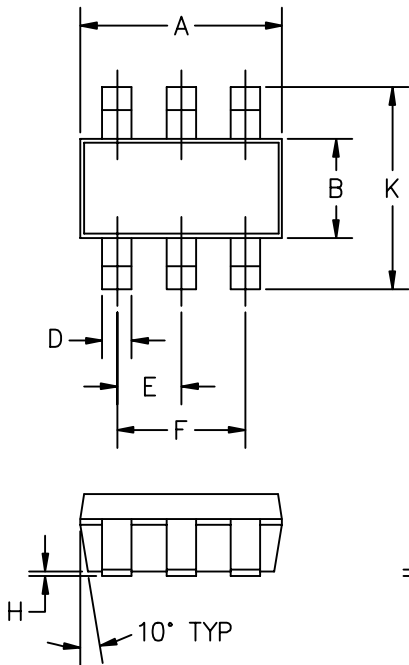

Figure 5 - Rail-To-Rail Protection Using RailClamp TVS Arrays

PROTECTION PRODUCTS

Outline Drawing



DIM ^N	DIMENSIONS ^①				NOTE
	INCHES		MM		
A	.110	.120	2.80	3.05	—
B	.059	.070	1.50	1.75	—
C	.036	.051	.90	1.30	—
D	.014	.020	.35	.50	—
E	.033	.040	.85	1.05	—
F	.067	.083	1.7	2.1	—
H	.0004	.006	.010	.150	—
J	.0035	.008	.090	.20	—
K	.102	.118	2.6	3.00	—

- ② PACKAGE OUTLINE EXCLUSIVE OF MOLD FLASH AND METAL BURR.
- ① CONTROLLING DIMENSIONS: MILLIMETERS.

Land Pattern

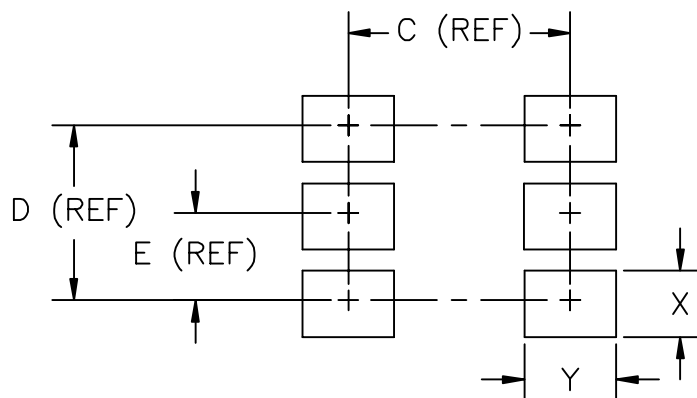

DIM ^N	DIMENSIONS		NOTE
	INCHES	MM	
C	.094	2.4	—
D	.074	1.9	—
E	.037	.95	—
X	.028	.7	—
Y	.039	1.0	—

PROTECTION PRODUCTS

Marking Codes

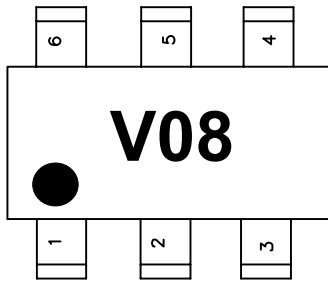

Part Number	Marking Code
SRV08-4	V08

Ordering Information

Part Number	Working Voltage	Qty per Reel	Reel Size
SRV08-4.TC	5.8V	3,000	7 Inch
SRV08-4.TG	5.8V	10,000	13 Inch

Contact Information

Semtech Corporation
 Protection Products Division
 200 Flynn Road, Camarillo, CA 93012
 Phone: (805)498-2111 FAX (805)498-3804