

SRV Series

SRAM Memory Card 256KB through 8MB

General Description

The WEDC SRAM Series (SRV) memory cards offer a high performance nonvolatile storage solution for code and data storage, disk caching, and write intensive mobile and embedded applications.

Packaged in PCMCIA type I or type II housing (type II for cards with extended battery backup time and 8MB cards), the WEDC SRAM SRV series is based on 1 or 4Mbit SRAM memories, providing densities from 256 Kilobytes to 8 Megabytes.

The SRV series of SRAM memory cards is a universal 3V/ 5V power supply and operates at speeds as high as 150ns. The cards are based on advanced CMOS technology providing very low power and reliable data retention characteristics. WEDC's SRAM cards contain a rechargeable lithium battery and recharge circuitry, eliminating the need for replaceable batteries found in many SRAM cards.

WEDC's standard cards are shipped with WEDC's SRAM Logo. Cards are also available with blank housings (no Logo). The blank housings are available in both a recessed (for label) and flat housing. Please contact WEDC sales representative for further information on Custom artwork.

Features

- High Performance SRAM memory Card
- Universal 3.3 to 5 Volt Supply allows for wider compatibility between systems.
- Fast Access times: 150ns @ 5V
250ns @ 3.3V
- x8/x16 PCMCIA standard interface
- Low Power CMOS technology provides very low power and reliable data retention characteristics
- standby current < 100µA typical
- Rechargeable Lithium battery with recharge circuitry
- eliminates the need for replaceable batteries
- standby current during recharge typically < 2mA
- battery backup time
• 7 months - type I card
• 18 months - type II card
typical based on 4MB (lower densities will have greater storage times)
- Unlimited write cycles, no endurance issues
- Optional Features:
 - 2KB EEPROM attribute memory containing CIS
 - Optional Hardware Write Protect switch
- PC Card Standard Type I or Type II Form Factor

Block Diagram

4MB SRAM Card Shown

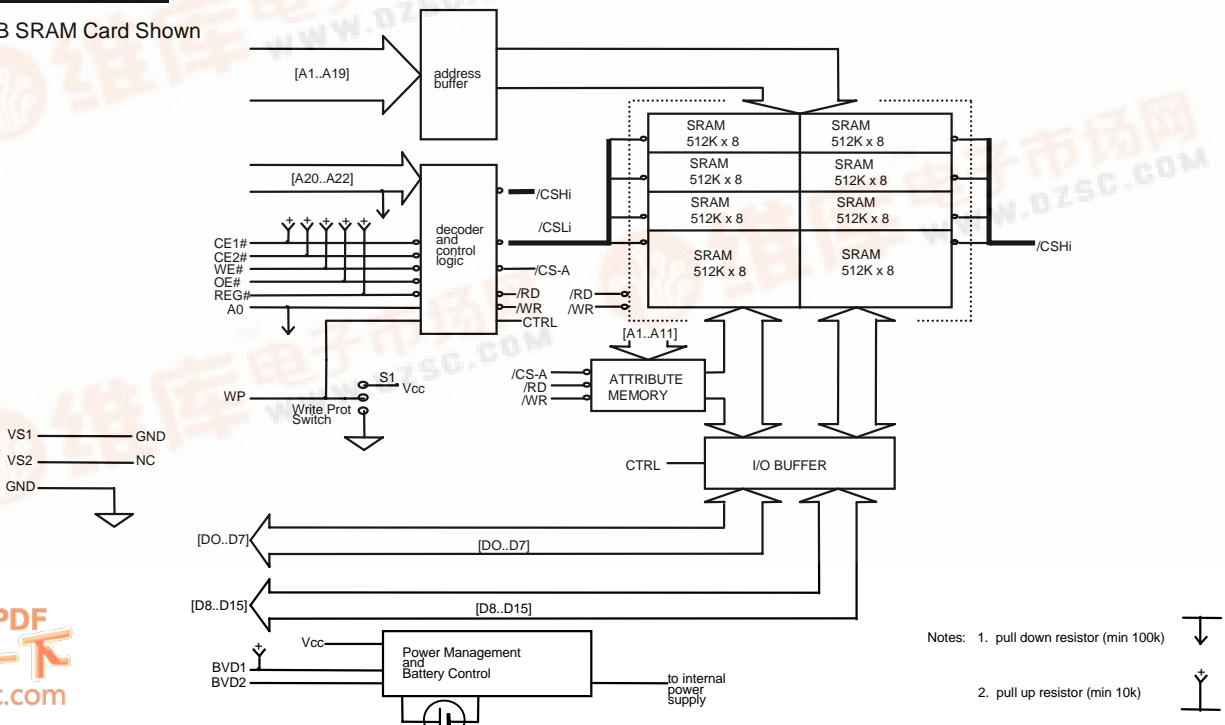

Notes: 1. pull down resistor (min 100k)
2. pull up resistor (min 10k)

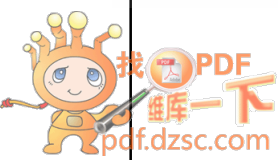

Pinout

Pin	Signal name	I/O	Function	Active
1	GND		Ground	
2	DQ3	I/O	Data bit 3	
3	DQ4	I/O	Data bit 4	
4	DQ5	I/O	Data bit 5	
5	DQ6	I/O	Data bit 6	
6	DQ7	I/O	Data bit 7	
7	CE1#	I	Card enable 1	LOW
8	A10	I	Address bit 10	
9	OE#	I	Output enable	LOW
10	A11	I	Address bit 11	
11	A9	I	Address bit 9	
12	A8	I	Address bit 8	
13	A13	I	Address bit 13	
14	A14	I	Address bit 14	
15	WE#	I	Write Enable	LOW
16	RDY/BSY#	O	Ready/Busy	N.C.
17	Vcc		Supply Voltage	
18	Vpp1		Prog. Voltage	N.C.
19	A16	I	Address bit 16	
20	A15	I	Address bit 15	
21	A12	I	Address bit 12	
22	A7	I	Address bit 7	
23	A6	I	Address bit 6	
24	A5	I	Address bit 5	
25	A4	I	Address bit 4	
26	A3	I	Address bit 3	
27	A2	I	Address bit 2	
28	A1	I	Address bit 1	
29	A0	I	Address bit 0	
30	DQ0	I/O	Data bit 0	
31	DQ1	I/O	Data bit 1	
32	DQ2	I/O	Data bit 2	
33	WP	O	Write Potect	HIGH
34	GND		Ground	

Pin	Signal name	I/O	Function	Active
35	GND		Ground	
36	CD1#	O	Card Detect 1	LOW
37	DQ11	I/O	Data bit 11	
38	DQ12	I/O	Data bit 12	
39	DQ13	I/O	Data bit 13	
40	DQ14	I/O	Data bit 14	
41	DQ15	I	Data bit 15	
42	CE2#	I	Card Enable 2	LOW
43	VS1	O	Voltage Sense 1	GND
44	N.C.			
45	N.C.			
46	A17	I	Address bit 17	256KB(2)
47	A18	I	Address bit 18	512KB(2)
48	A19	I	Address bit 19	1MB(2)
49	A20	I	Address bit 20	2MB(2)
50	A21	I	Address bit 21	4MB(2)
51	Vcc		Supply Voltage	
52	Vpp2		Prog. Voltage	N.C.
53	A22		Address bit 22	8MB(2,4)
54	A23		N.C.	
55	A24		N.C.	
56	A25		N.C.	
57	VS2	O	Voltage Sense 2	N.C.
58	N.C.			
59	Wait#	O	Extended Bus Cycle	Low
60	N.C.			
61	REG#	I	Attrib Mem Select	Low
62	BVD2	O	Bat. Volt. Detect 2	
63	BVD1	O	Bat. Volt. Detect 1	(3)
64	DQ8	I/O	Data bit 8	
65	DQ9	I/O	Data bit 9	
66	DQ10	O	Data bit 10	
67	CD2#	O	Card Detect 2	LOW
68	GND		Ground	

Notes:

1. CD1# and CD2# are grounded internal to PC Card.
2. Shows density for which specified address bit is MSB. Higher order address bits are no connects (ie 1MB A19 is MSB, A20 - A21 are NC).
3. BVD1 is an open drain output with a 10K ohm internal pull-up resistor.
4. The A22 Address line for 8MB capacities is also used for 6MB cards.



Mechanical

Type I

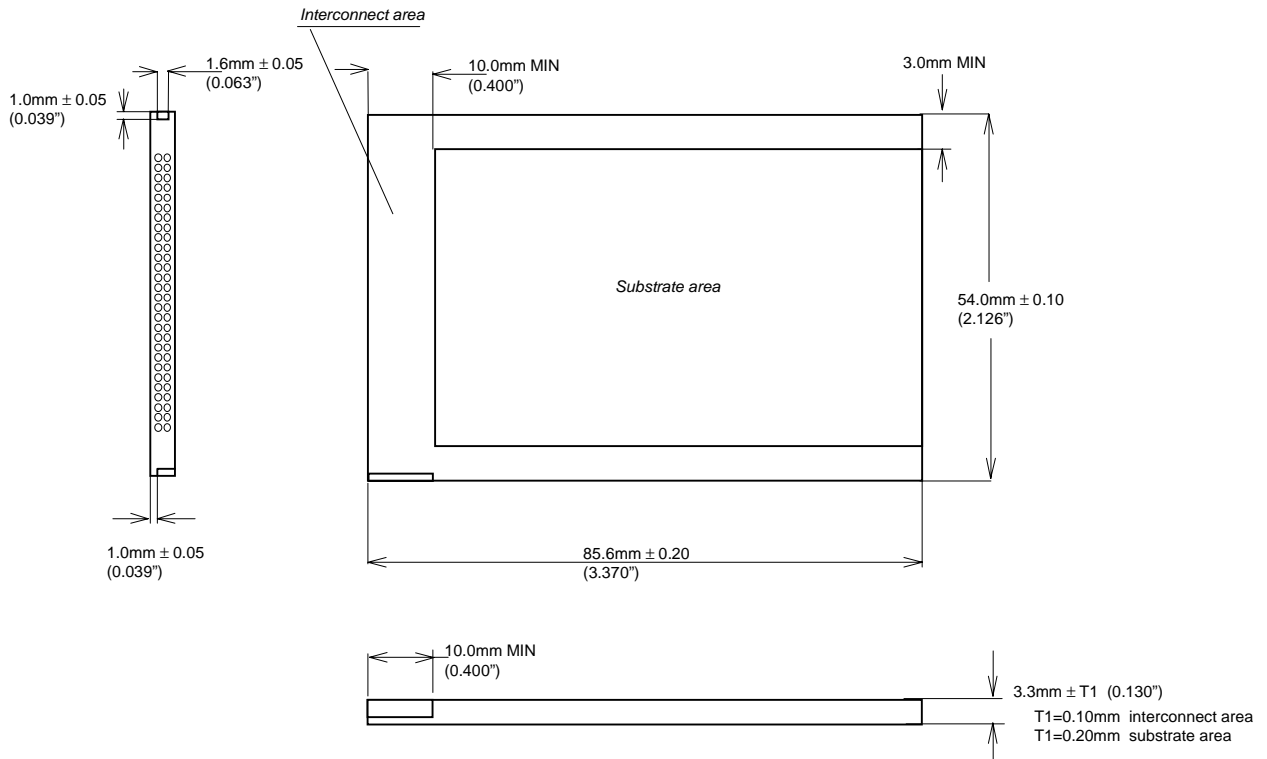

Type II

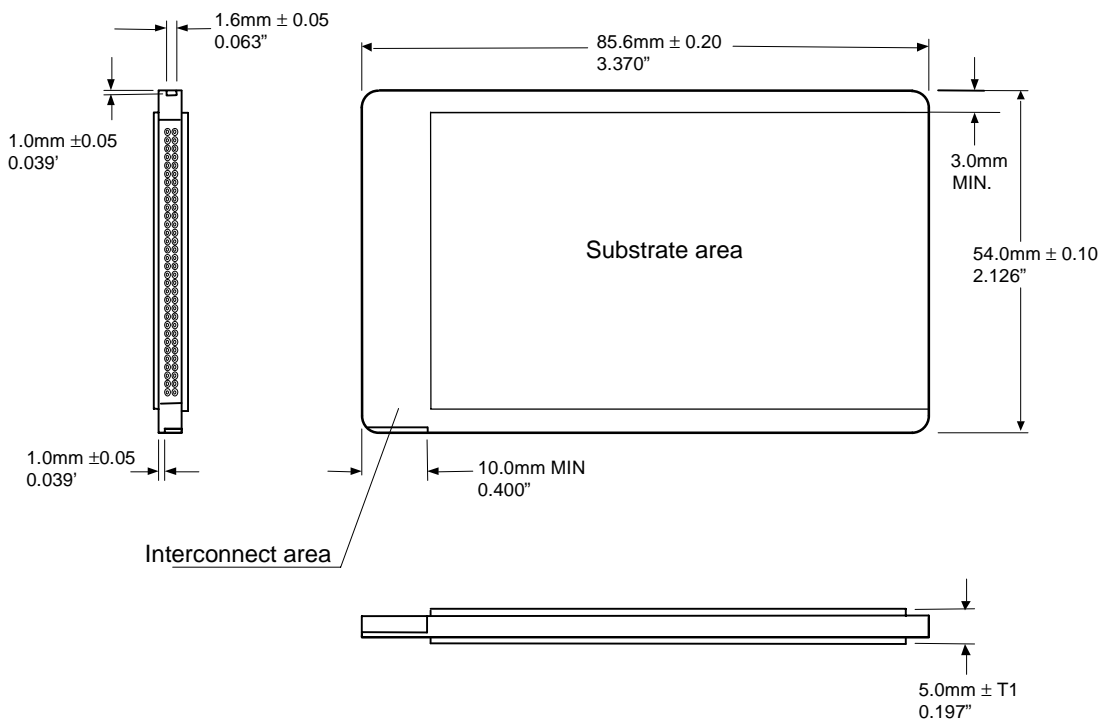

Card Signal Description

Symbol	Type	Name and Function
A0 - A25	INPUT	ADDRESS INPUTS: A0 through A25 enable direct addressing of up to 64MB of memory on the card. Signal A0 is not used in word access mode. A25 is the most significant bit. (address pins used are based on card density, see pinout for highest used address pin)
DQ0 - DQ15	INPUT/OUTPUT	DATA INPUT/OUTPUT: DQ0 THROUGH DQ15 constitute the bi-directional databus. DQ0 - DQ7 constitute the lower (even) byte and DQ8 - DQ15 the upper (odd) byte. DQ15 is the MSB.
CE1 #, CE2 #	INPUT	CARD ENABLE 1 AND 2: CE1 # enables even byte accesses, CE2 # enables odd byte accesses. Multiplexing A0, CE1 # and CE2 # allows 8-bit hosts to access all data on DQ0 - DQ7.
OE#	INPUT	OUTPUT ENABLE: Active low signal enabling read data from the memory card.
WE#	INPUT	WRITE ENABLE: Active low signal gating write data to the memory card.
RDY/BSY #	OUTPUT	READY/BUSY OUTPUT: Not used for SRAM cards
CD1 #, CD2 #	OUTPUT	CARD DETECT 1 and 2: Provide card insertion detection. These signals are connected to ground internally on the memory card. The host socket interface circuitry shall supply 10K-ohm or larger pull-up resistors on these signal pins.
WP	OUTPUT	WRITE PROTECT: Follows hardware Write Protect Switch. When Switch is placed in on position, signal is pulled high (10K ohm). When switch is off signal is pulled low.
VPP1, VPP2	N.C.	PROGRAM/ERASE POWER SUPPLY: Not used for SRAM cards.
VCC		CARD POWER SUPPLY: 3.3V / 5.0V for all internal circuitry.
GND		GROUND: for all internal circuitry.
REG #	INPUT	ATTRIBUTE MEMORY SELECT : only used with cards built with optional attribute memory.
RST	INPUT	RESET: Not used for SRAM cards
WAIT #	OUTPUT	WAIT: This signal is pulled high internally for compatibility. No wait states are generated.
BVD1, BVD2	OUTPUT	BATTERY VOLTAGE DETECT: Provides status of Battery voltage. BVD2 = BVD1 = Voh (battery voltage is guaranteed to retain data) BVD2 = Vol, BVD1 = Voh (data is valid, battery recharge required) BVD2 = BVD1 = Vol (data may no longer be valid, battery requires extended recharge)
VS1, VS2	OUTPUT	VOLTAGE SENSE: Notifies the host socket of the card's VCC requirements. VS1 is grounded and VS2 is open to indicate a 3.3V/5V 16 bit card, with a 5V key, has been inserted.
RFU		RESERVED FOR FUTURE USE
N.C.		NO INTERNAL CONNECTION TO CARD: pin may be driven or left floating

SRAM

FUNCTIONAL TRUTH TABLE

READ function

Function Mode						<i>Common Memory</i>			<i>Attribute Memory</i>		
	/CE2	/CE1	A0	/OE	/WE	/REG	D15-D8	D7-D0	/REG	D15-D8	D7-D0
Standby Mode	H	H	X	X	X	X	High-Z	High-Z	X	High-Z	High-Z
Byte Access (8 bits)	H	L	L	L	H	H	High-Z	Even-Byte	L	High-Z	Even-Byte
	H	L	H	L	H	H	High-Z	Odd-Byte	L	High-Z	Not Valid
Word Access (16 bits)	L	L	X	L	H	H	Odd-Byte	Even-Byte	L	Not Valid	Even-Byte
Odd-Byte Only Access	L	H	X	L	H	H	Odd-Byte	High-Z	L	Not Valid	High-Z

WRITE function

Standby Mode	H	H	X	X	X	X	X	X	X	X	X
Byte Access (8 bits)	H	L	L	H	L	H	X	Even-Byte	L	X	Even-Byte
	H	L	H	H	L	H	X	Odd-Byte	L	X	X

SRV Series

Absolute Maximum Ratings ⁽²⁾

Operating Temperature TA (ambient)	
Commercial	0°C to +60 °C
Industrial	-40°C to +85 °C
Storage Temperature	
Commercial	0°C to +60 °C
Industrial	-40°C to +85 °C
Voltage on any pin relative to VSS	-0.5V to +5.5V (1)
VCC supply Voltage relative to VSS	-0.5V to +7.0V

Notes:

(1) During transitions, inputs may undershoot to -2.0V or overshoot to VCC +2.0V for periods less than 20ns.

(2) Stress greater than those listed under "Absolute Maximum Ratings" may cause permanent damage to the device. This is a stress rating only and functional operation at these or any other conditions greater than those indicated in the operational sections of this specification is not implied. Exposure to absolute maximum rating conditions for extended periods may affect reliability.

DC Characteristics ⁽¹⁾

CMOS Test Conditions: VIL = VSS ± 0.2V, VIH = 5V ± 0.2V

Sym	Parameter	Density	Notes	Min	Typ ⁽³⁾	Max	Units	Test Conditions
ICC	VCC Active Current	64KB	1		90	180	mA	VCC = 5.25V tcycle = 150ns
		128KB		90	180			
		256KB		90	180			
		512KB		90	180			
		1MB to 8MB		110	190			
ICCS	VCC Standby Current	All	2,4	< 0.1	< 1	10	mA	VCC = 5.25V Control Signals = VCC
ILI	Input Leakage Current	All	5,6			±20	µA	VCC = VCCMAX Vin = VCC or VSS
ILO	Output Leakage Current	All	6			±20	µA	VCC = VCCMAX Vout = VCC or VSS
VIL	Input Low Voltage	All	6	0		0.8	V	
VIH	Input High Voltage	All	6	3.85		VCC +0.5	V	
VOL	Output Low Voltage	All	6			0.4	V	IOL = 3.2mA
VOH	Output High Voltage	All	6	VCC-0.4		VCC	V	IOH = -2.0mA

Notes:

- All currents are for x16 mode and are RMS values unless otherwise specified.
- Control Signals: CE₁#, CE₂#, OE#, WE#, REG#.
- Typical: VCC = 5V, T = +25C.
- ICCS includes battery recharge current. Value depends on battery discharge level. ICCS min is specified for fully charged battery. ICCS typical value is specified for battery discharge to 2.7V. ICCS max is specified for a fully discharged battery (0V). Battery will recharge to 1.5V in 20 sec.
- Values are the same for byte and word wide modes for all card densities.
- Exceptions: Leakage currents on CE1#, CE2#, OE#, REG# and WE# will be < 500 µA when VIN = GND due to internal pull-up resistors.

Battery Characteristics

Parameter	Density	Notes	SRV11-14	SRV01-04		Units	Conditions
			Type I	Type I	Type II		
Battery Life	All	(1)	min 10	min 10		years	Normal operation, T=25C
Battery Backup Time	256KB	(2)	-	24	60	months (typical)	T=25C Battery backup time is a calculated value and is not guaranteed. This should not be used to schedule battery recharging.
	512KB, 1MB		32	18	45		
	2MB		22	12	30		
	4MB		12	7	17		
	6MB		12	7	17		
	8MB		-	-	12		

Notes:

- Battery Life refers to functional lifetime of battery.



AC Characteristics

Read Timing Parameters

SYM (PCMCIA)	Parameter	5.0V		3.3V		Unit
		Min	Max	Min	Max	
t _{RC}	Read Cycle Time	150		250		ns
t _a (A)	Address Access Time		150		250	ns
t _a (CE)	Card Enable Access Time		150		250	ns
t _a (OE)	Output Enable Access Time		75		125	ns
t _{su} (A)	Address Setup Time	20		30		ns
t _{su} (CE)	Card Enable Setup Time	0		0		ns
t _h (A)	Address Hold Time	20		20		ns
t _h (CE)	Card Enable Hold Time	20		20		ns
t _v (A)	Output Hold from Address Change	0		0		ns
t _{dis} (CE)	Output Disable Time from CE#		75		100	ns
t _{dis} (OE)	Output Disable Time from OE#		75		100	ns
t _{dis} (CE)	Output Enable Time from CE#	5		5		ns
t _{dis} (OE)	Output Enable Time from OE#	5		5		ns

Note: AC timing diagrams and characteristics are guaranteed to meet or exceed PCMCIA 2.1 specifications.

Read Timing Diagram

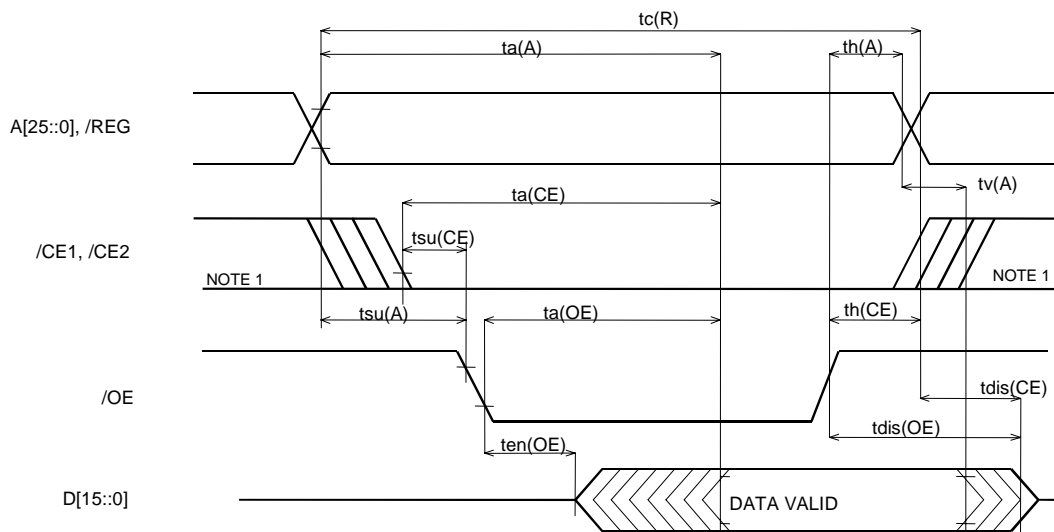

Note: Signal may be high or low in this area.

Write Timing Parameters

SYM (PCMCIA)	Parameter	5.0V		3.3V		Unit
		Min	Max	Min	Max	
t_{cW}	Write Cycle Time	150		250		ns
$t_w(WE)$	Write Pulse Width	80		150		ns
$t_{su}(A)$	Address Setup Time	20		30		ns
$t_{su}(A-WEH)$	Address Setup Time for WE#	100		180		ns
$t_{su}(CE-WEH)$	Card Enable Setup Time for WE#	100		180		ns
$t_{su}(D-WEH)$	Data Setup Time for WE#	50		80		ns
$t_h(D)$	Data Hold Time	20		30		ns
$t_{rec}(WE)$	Write Recover Time	20		30		ns
$t_{dis}(WE)$	Output Disable Time from WE#		75		100	ns
$t_{dis}(OE)$	Output Disable Time from OE#		75		100	ns
$t_{en}(WE)$	Output Enable Time from WE#	5		5		ns
$t_{dis}(OE)$	Output Enable Time from OE#	5		5		ns
$t_{su}(OE-WE)$	Output Enable Setup from WE#	10		10		ns
$t_h(OE-WE)$	Output Enable Hold from WE#	10		10		ns
$t_{su}(CE)$	Card Enable Setup Time from OE#	0		0		ns
$t_h(CE)$	Card Enable Hold Time	20		20		ns

Note: AC timing diagrams and characteristics are guaranteed to meet or exceed PCMCIA 2.1 specifications.

Write Timing Diagram

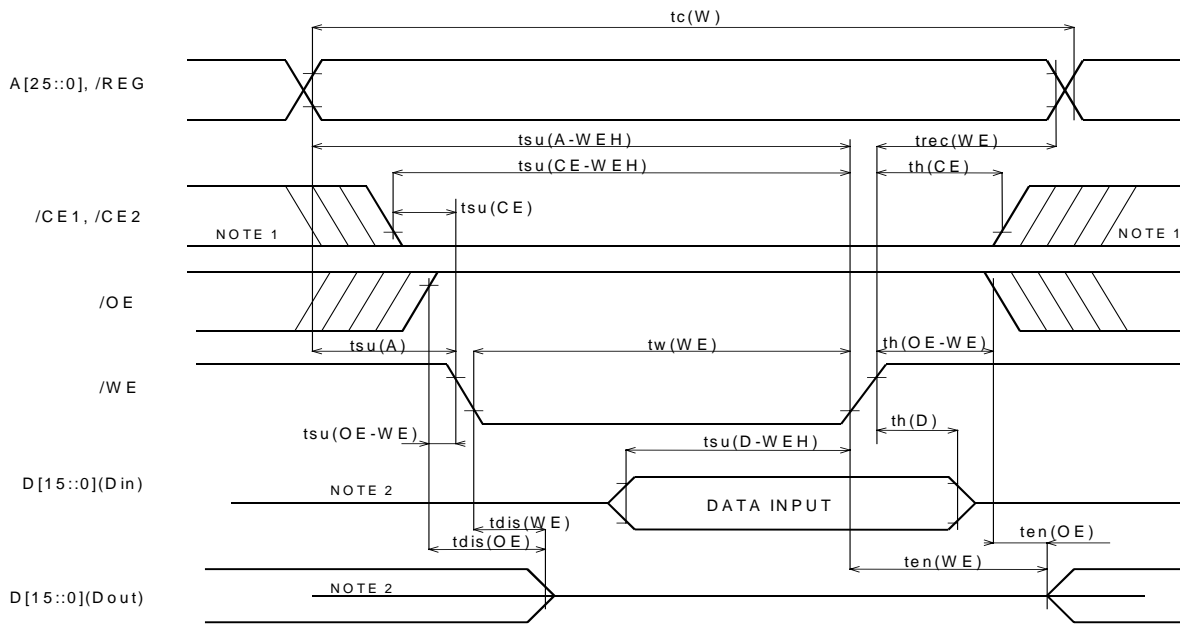

Notes:

- Signal may be high or low in this area.
- When the data I/O pins are in the output state, no signals shall be applied to the data pins (D15 - D0) by the host system.



PRODUCT MARKING

WED 8P512SRV0100C15 C995 9915

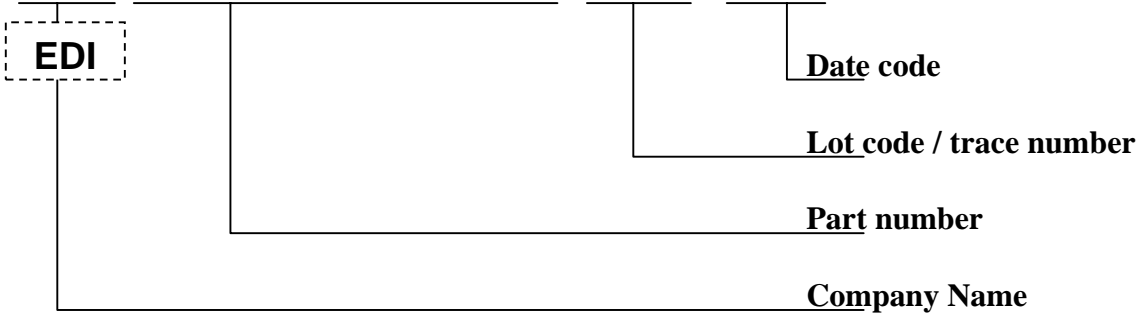

Note:

Some products are currently marked with our pre-merger company name/acronym (EDI). During our transition period, some products will also be marked with our new company name/acronym (WED). Starting October 2000 all PCMCIA products will be marked only with the WED prefix.

PART NUMBERING

8 P 512 SRV01 00 C 15

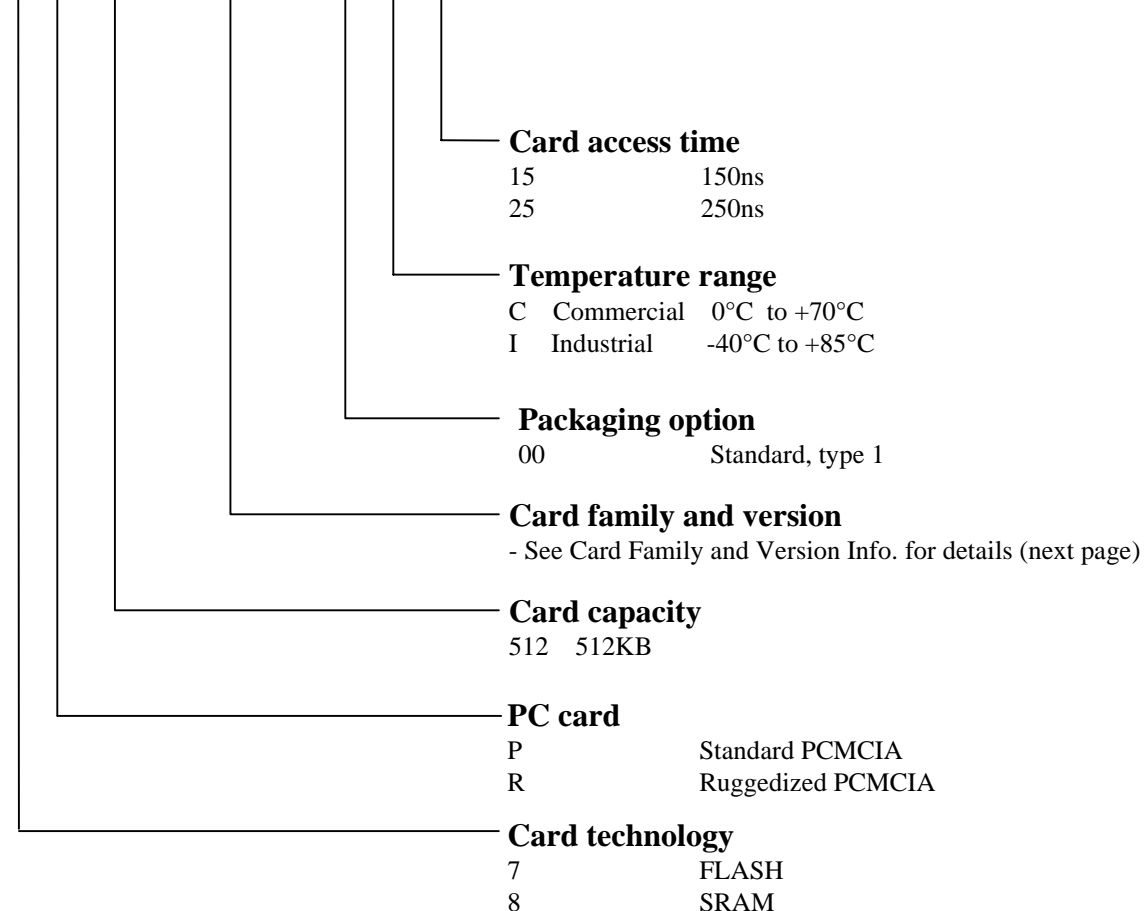



Ordering Information

8P XXX SRV YY SS T ZZ

where

XXX:	256*	256KB
	512*	512KB
	001	1MB
	002	2MB
	004	4MB
	006	6MB
	008*	8MB

*= Capacities available only in SRV01-SRV04

YY:	01	no attribute memory, no Write Protect Switch
	02	with attribute memory, no Write Protect Switch
	03	with Write Protect Switch, no attribute memory
	04	with attribute memory, with Write Protect Switch
	11	Extended Battery Backup Time, no attribute memory, no Write Protect Switch
	12	Extended Battery Backup Time, with attribute memory, no Write Protect Switch
	13	Extended Battery Backup Time, with Write Protect Switch, no attribute memory
	14	Extended Battery Backup Time, with attribute memory, with Write Protect Switch

SS:	00	WEDC SRAM Logo Type I
	01	Blank Housing, Type I
	02	Blank Housing, Type I Recessed
	03	WEDC SRAM Logo, Type II (8MB and extended battery backup time)
	04	Blank Housing, Type II (8MB and extended battery backup time)
	05	Blank Housing, Type II Recessed (8MB and extended battery backup time)

T:	C	Commercial
	I	Industrial

ZZ:	15	150ns
------------	-----------	--------------



REVISION HISTORY		
Date of revision	Version	Description
27-Sep-99	0	Initial release
2-Jun-00	1	Added Page 8, Added SRV11-14 to page 9, Changed Page Header

Filename: SRV Dsht Rev1.ppt

White Electronic Designs Corporation

One Research Drive, Westborough, MA 01581, USA

tel: (508) 366 5151

fax: (508) 836 4850

www.whiteedc.com



WHITE ELECTRONIC DESIGNS