



# SMD2920 Surface Mount PTC Devices

R.O.C. Patent#415624

- The SMD2920 Series, a polymer-based Positive Temperature Coefficient (PTC) device to protect electrical circuits against overcurrent conditions with resettable feature, is fully compatible with current industrial standards.
- The new designed SMD2920 Series provides surface mount overcurrent protection with superior performance.
- Application: The SMD2920 Series is ideal for computers and peripherals and can be applied to almost anywhere there is a low voltage power supply and a load to be protected.
- The solder plated termination is designed to meet or exceed solderability specifications and provide excellent solder joint inspectability.
- Agency Approval: UL File # E201431.  
CSA File # CA115375-1



## ELECTRICAL CHARACTERISTICS

Part Number	I <sub>hold</sub> (A)	I <sub>trip</sub> (A)	V <sub>max</sub> (Vdc)	I <sub>max</sub> (A)	P <sub>dmax</sub> (W)	Maximum Time To Trip		Resistance		Agency Approval
						Current (A)	Time (Sec.)	R <sub>min</sub> ( )	R <sub>1max</sub> ( )	
SMD2920P030TS	0.30	0.60	60	10	1.5	1.50	3.00	1.200	4.800	UL CSA TÜV
SMD2920P050TS	0.50	1.00	60	10	1.5	2.50	4.00	0.350	1.400	UL CSA TÜV
SMD2920P075TS	0.75	1.50	30	40	1.5	8.00	0.30	0.350	1.000	UL CSA TÜV
SMD2920P100TS	1.10	2.20	33	40	1.5	8.00	0.50	0.120	0.410	UL CSA TÜV
SMD2920P125TS	1.25	2.50	15	40	1.5	8.00	2.00	0.070	0.250	UL CSA TÜV
SMD2920P150TS	1.50	3.00	33	40	1.5	8.00	2.00	0.080	0.230	UL CSA TÜV
SMD2920P185TS	1.85	3.70	33	40	1.5	8.00	2.50	0.065	0.150	UL CSA TÜV
SMD2920P200TS	2.00	4.00	15	40	1.5	8.00	5.00	0.050	0.125	UL CSA TÜV
SMD2920P200TS/24	2.00	4.00	24	40	1.5	8.00	5.00	0.050	0.125	UL CSA TÜV
SMD2920P250TS	2.50	5.00	15	40	1.5	8.00	10.00	0.035	0.085	UL CSA TÜV
SMD2920P260TS	2.60	5.20	6	40	1.5	8.00	10.00	0.025	0.075	UL CSA TÜV
SMD2920P300TS	3.00	6.00	6	40	1.5	8.00	20.00	0.015	0.048	UL CSA TÜV
SMD2920P300TS/15	3.00	6.00	15	40	1.5	8.00	20.00	0.015	0.048	UL CSA TÜV

Note: I<sub>hold</sub> = Hold current: maximum current device will pass without tripping in 20 still air.

I<sub>trip</sub> = Trip current: minimum current at which the device will trip in 20 still air.

V<sub>max</sub> = Maximum voltage device can withstand without damage at rated current (I<sub>max</sub>)

I<sub>max</sub> = Maximum fault current device can withstand without damage at rated voltage (V<sub>max</sub>)

P<sub>d</sub> = Power dissipated from device when in the tripped state at 20 still air.

R<sub>min</sub> = Minimum resistance of device in initial (un-soldered) state.

R<sub>1max</sub> = Maximum resistance of device at 20 measured one hour after tripping or reflow soldering of 260 for 20 sec.

**Caution: Operation beyond the specified rating may result in damage and possible arcing and flame.**  
Specifications are subject to change without notice.



Polytronics Technology Corp  
REGISTERED TO ISO 9001  
FILE NO.A8727



### **How to Select a Polymer PTC fuse:**

- (1) Determine the following operating parameters for the circuits:
  - (A) Normal Operating Current (I hold)
  - (B) Maximum Circuit Voltage (V max)
  - (C) Maximum Interrupt Current (I max)
  - (D) Normal Operating Temperature (min /max )
- (2) Select the device form factor and dimension suitable for the application:
  - Surface Mount Device (SMD Series)
  - Radial Leaded Device (RLD Series)
  - Axial Leaded Strap Device (STD Series)
  - Other Custom-designed Device (Disc/Chip)
- (3) Compare the maximum ratings for V max and I max of the PTC device with the circuit in application and make sure that the circuit's requirement does not exceed the device ratings.
- (4) Check that the PTC device's trip time (time-to-trip) will protect the circuit.
- (5) Verify that the circuit operating temperatures are within the PTC device's normal operating temperature range.
- (6) Verify the performance and suitability of the chosen PTC device in the application.



# SMD2920 Surface Mount PTC Devices

R.O.C. Patent#415624

## THERMAL DERATING CURVE FOR SMD2920 SERIES

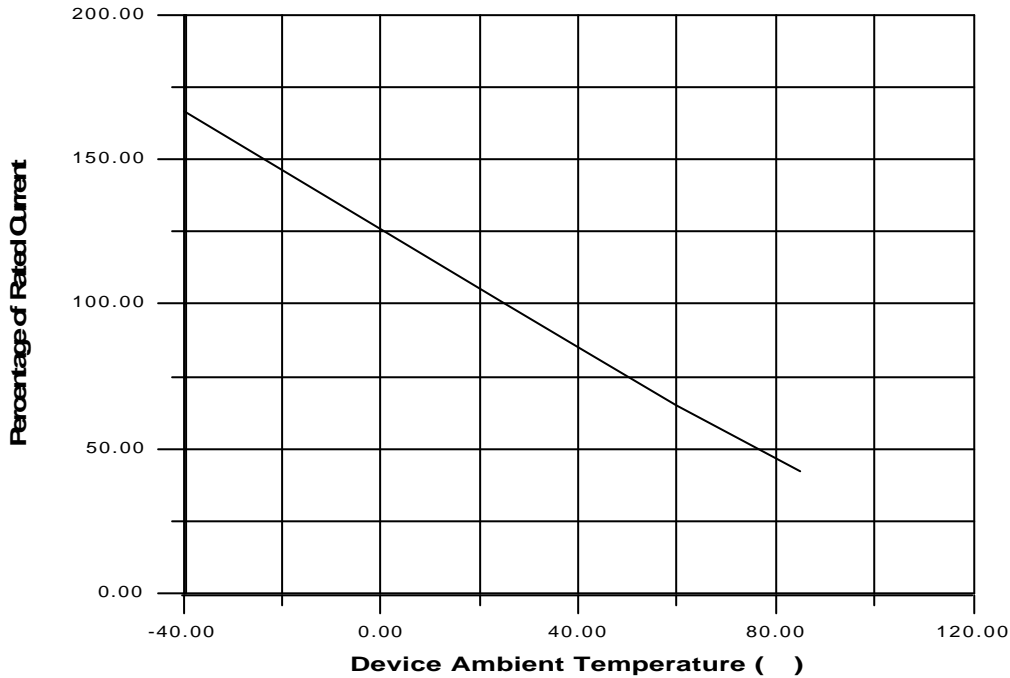

## THERMAL DERATING CHART FOR SMD2920 SERIES – I<sub>hold</sub> (Amps)

Model	Ambient Operation Temperature								
	-40	-20	0	23	40	50	60	70	85
SMD2920P030TS	0.45	0.40	0.35	0.30	0.25	0.23	0.20	0.17	0.14
SMD2920P050TS	0.76	0.67	0.59	0.50	0.42	0.38	0.33	0.29	0.23
SMD2920P075TS	1.13	1.01	0.88	0.75	0.62	0.56	0.50	0.44	0.34
SMD2920P100TS	1.66	1.47	1.29	1.10	0.91	0.83	0.73	0.64	0.50
SMD2920P125TS	1.89	1.68	1.46	1.25	1.04	0.94	0.83	0.73	0.56
SMD2920P150TS	2.27	2.01	1.76	1.50	1.25	1.13	1.00	0.87	0.74
SMD2920P185TS	2.80	2.47	2.17	1.85	1.54	1.39	1.22	1.07	0.85
SMD2920P200TS	3.02	2.68	2.34	2.00	1.66	1.50	1.32	1.16	0.90
SMD2920P200TS/24	3.02	2.68	2.34	2.00	1.66	1.50	1.32	1.16	0.90
SMD2920P250TS	3.78	3.35	2.93	2.50	2.08	1.88	1.65	1.45	1.13
SMD2920P260TS	3.64	3.25	2.91	2.60	2.26	2.08	1.95	1.74	1.48
SMD2920P300TS	4.53	4.02	3.51	3.00	2.52	2.26	1.99	1.75	1.34
SMD2920P300TS/15	4.53	4.02	3.51	3.00	2.52	2.26	1.99	1.75	1.34

## AVERAGE TIME-CURRENT CURVE FOR SMD2920 SERIES

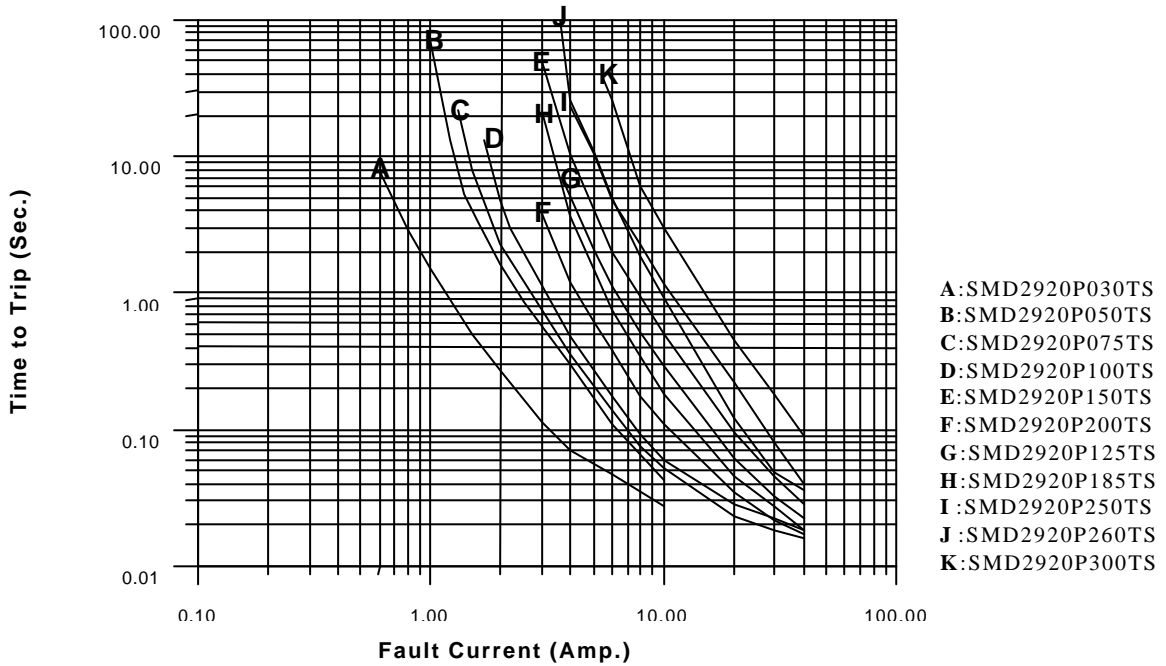

## SOLDER REFLOW

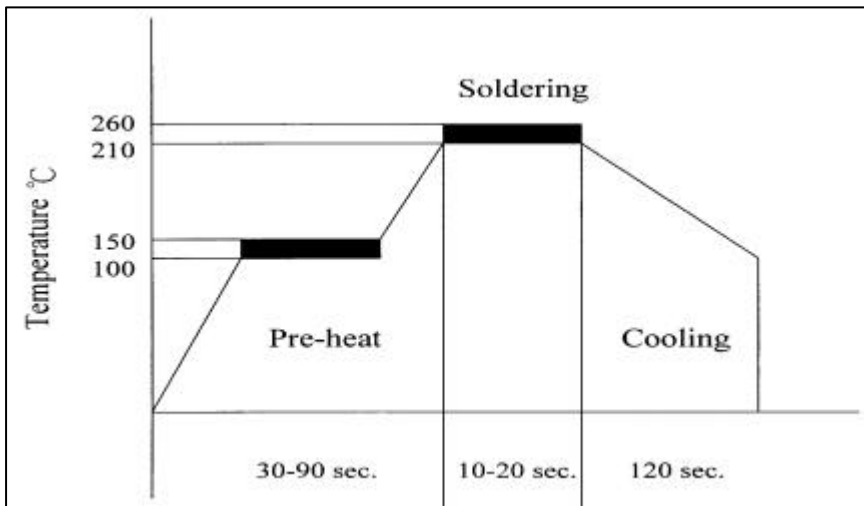

- Recommended reflow methods: IR, vapor phase oven, hot air oven
- Devices are not designed to be wave soldered to the bottom side of the board.
- Recommended maximum paste thickness is 0.25mm (0.010 inch)
- Devices can be cleaned using standard industry methods and solvents.

*Note: If reflow temperatures exceed the recommended profile, devices may not meet the performance requirements.*

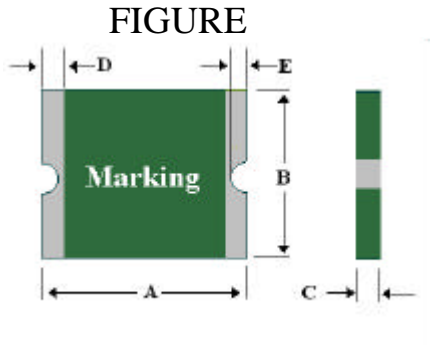

### SOLDER PAD LAYOUTS

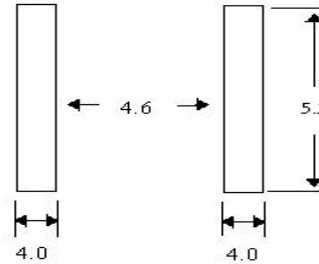

### PHYSICAL DIMENSIONS (mm)

Part Number	A		B		C		D		E
	Min.	Max.	Min.	Max.	Min.	Max.	Min.	Min.	Max.
SMD2920P030TS	6.73	7.98	4.80	5.44	0.75	1.25	0.30	0.25	2.00
SMD2920P050TS	6.73	7.98	4.80	5.44	0.75	1.25	0.30	0.25	2.00
SMD2920P075TS	6.73	7.98	4.80	5.44	0.75	1.25	0.30	0.25	2.00
SMD2920P100TS	6.73	7.98	4.80	5.44	0.55	1.00	0.30	0.25	2.00
SMD2920P125TS	6.73	7.98	4.80	5.44	0.55	1.00	0.30	0.25	2.00
SMD2920P150TS	6.73	7.98	4.80	5.44	0.75	1.25	0.30	0.25	2.00
SMD2920P185TS	6.73	7.98	4.80	5.44	0.75	1.25	0.30	0.25	2.00
SMD2920P200TS	6.73	7.98	4.80	5.44	0.75	1.25	0.30	0.25	2.00
SMD2920P250TS	6.73	7.98	4.80	5.44	0.75	1.25	0.30	0.25	2.00
SMD2920P260TS	6.73	7.98	4.80	5.44	0.55	1.00	0.30	0.25	2.00
SMD2920P300TS	6.73	7.98	4.80	5.44	0.75	1.25	0.30	0.25	2.00
SMD2920P300TS/15	6.73	7.98	4.80	5.44	0.75	1.25	0.30	0.25	2.00

### ENVIRONMENTAL SPECIFICATIONS

Operating/Storage Temperature	-40 to +85
Maximum Device Surface Temperature in Tripped State	125
Passive Aging	+85 , 1000 hours ±5% typical resistance change
Humidity Aging	+85 , 85%R.H. 1000 hours ±5% typical resistance change
Thermal Shock	MIL-STD-202 Method 107G +85 /-40 20 times -30% typical resistance change
Solvent Resistance	MIL-STD-202, Method 215 No change
Vibration	MIL-STD-883C, Method 2007.1, Condition A No change

### PHYSICAL SPECIFICATIONS

Terminal Material	Solder-Plated Copper (Solder Material: 63/37 SnPb)
Lead Solderability	Meets EIA Specification RS186-9E, ANSI/J-STD-002 Category 3.
Packaging	16 mm tape on 7 inch reel per EIA-481-1 (equivalent to IEC286, part 3) 2000 devices per reel for P100TS, P125TS & P260 others : 1500 devices per reel

Specifications are subject to change without notice.

## TAPE SPECIFICATIONS: EIA-481-1

	P030TS-P075TS	P100TS	P150TS-P185TS
	P050TS	P125TS	P200TS-P250TS
		P260TS	P300TS
W	16.0+/-0.30	16.0+/-0.30	16.0+/-0.30
F	7.5+/-0.05	7.5+/-0.05	7.5+/-0.05
E <sub>1</sub>	1.75+/-0.10	1.75+/-0.10	1.75+/-0.10
D <sub>0</sub>	1.55+/-0.05	1.55+/-0.05	1.55+/-0.05
D <sub>1</sub>	1.5+/-0.10	1.5+/-0.10	1.5+/-0.10
P <sub>0</sub>	4.0+/-0.10	4.0+/-0.10	4.0+/-0.10
P <sub>1</sub>	8.0+/-0.10	8.0+/-0.10	8.0+/-0.10
P <sub>2</sub>	2.0+/-0.05	2.0+/-0.05	2.0+/-0.05
A <sub>0</sub>	5.45+/-0.10	5.45+/-0.10	5.45+/-0.10
B <sub>0</sub>	7.65+/-0.10	7.65+/-0.10	7.65+/-0.10
T	0.25+/-0.10	0.25+/-0.10	0.25+/-0.10
K <sub>0</sub>	1.25+/-0.10	1.00+/-0.10	1.45+/-0.10
Leader min.	390	390	390
Trailer min.	160	160	160

(mm)

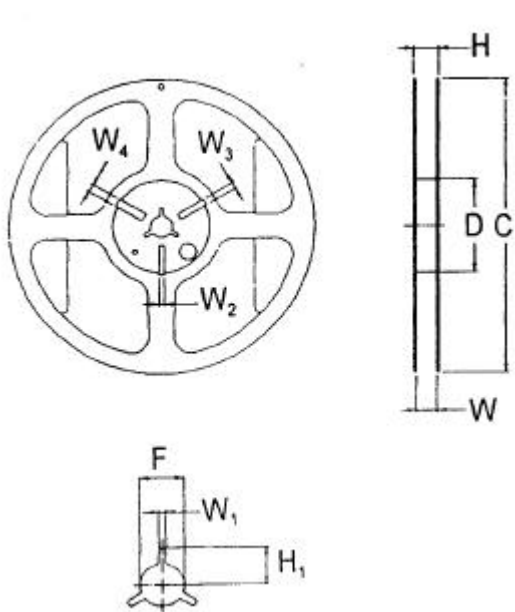
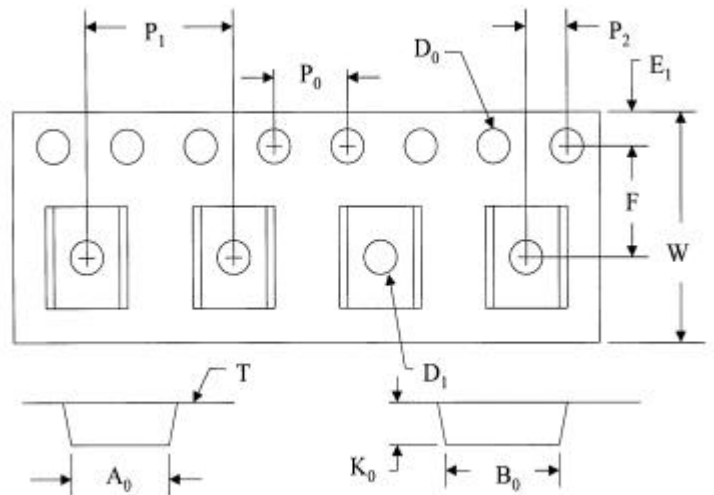

## REEL DIMENSIONS: EIA-481-1

H	12.0+/-0.15
W	9.0+/-0.5
D	60+/-0.5
F	13.0+/-0.2
C	178+/-1.0
H <sub>1</sub>	11+/-0.5
W <sub>1</sub>	2.5+/-0.5
W <sub>2</sub>	3.0+/-0.5
W <sub>3</sub>	4.0+/-0.5
W <sub>4</sub>	5.0+/-0.5

(mm)



# SMD2920 Surface Mount PTC Devices

R.O.C. Patent#415624

## PART NUMBERING SYSTEM

SMD 2920 P \_\_\_\_\_ TS

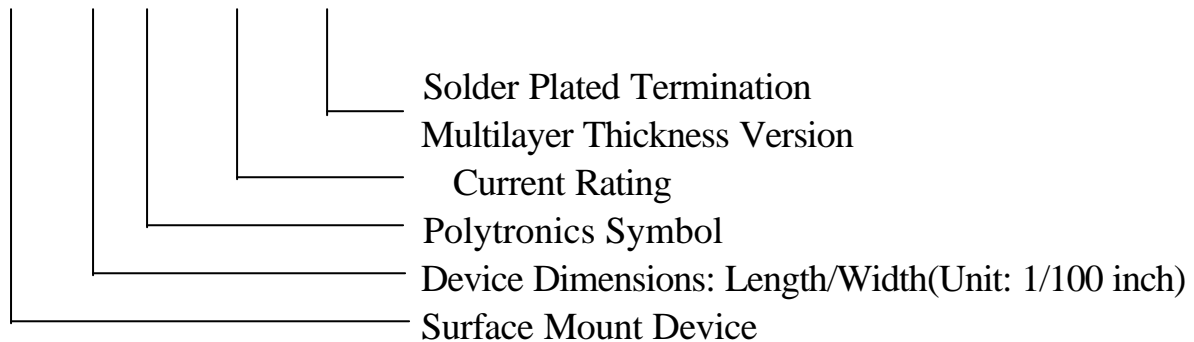

## CROSS REFERENCE

Polytronics/ EVERFUSE™	Cross Reference	
	Raychem/ PolySwitch®	Bourns/ Multifuse®
SMD2920P030TS	SMD030	MF-SM030
SMD2920P050TS	SMD050	MF-SM050(30Vdc)
SMD2920P075TS	SMD075	MF-SM075
SMD2920P100TS	SMD100/33	MF-SM100(30Vdc)
SMD2920P125TS	SMD125	MF-SM125
SMD2920P150TS	SMD150/33 (3425)	MF-SM150(15Vdc)
SMD2920P185TS	SMD185 (3425)	N/A
SMD2920P200TS	SMD200 (3425)	MF-SM200 (3425)
SMD2920P200TS/24	N/A	N/A
SMD2920P250TS	SMD250 (3425)	MF-SM250 (3425)
SMD2920P260TS	SMD260	MF-SM260
SMD2920P300TS	SMD300	N/A
SMD2920P300TS/15	N/A	N/A

“EVERFUSE” is a registered trademark of Polytronics Technology Corp.

“Multifuse” is a registered trademark of Bourns , Inc.

“PolySwitch” is a registered trademark of Raychem Corporation.

Specifications are subject to change without notice.



SMD2920 Surface Mount PTC Devices

R.O.C. Patent#415624

