



# SMB135

Advanced Information

## Programmable, USB/AC, Switch-Mode Battery Charger

### FEATURES & APPLICATIONS

- Programmable USB/AC Li-Ion battery charger
- High-efficiency current-mode PWM controller
  - 750kHz to 1.25MHz switching frequency
  - 0% to 100% duty-cycle
- 4.35 to 6.0V input voltage range
- Small 1.3 x 2.1 uCSP™-15 package (0.4mm pitch)
- High-accuracy output voltage regulation: 1%
- Low reverse leakage current
- Digital programming of all major parameters via I<sup>2</sup>C interface (with several addresses) and non-volatile memory
  - Battery voltage set point
  - Pre-charge, fast charge, termination current
  - Fast charge voltage threshold
  - Temperature limits
  - Automatic restart threshold
- Status indicator
- Stability with ceramic capacitors
- Wide range of protection features
  - Thermal monitor
  - Input/output over-voltage lockout

### Applications

- GSM Handsets
- UMTS Handsets
- Portable Media Players
- Digital camcorders/still cameras
- Handheld GPS/PDA's

### INTRODUCTION

The SMB135 is a programmable single-cell lithium-ion/lithium-polymer battery charger for a variety of portable applications. The device provides a simple and efficient way to charge high-capacity Li-Ion batteries via a USB port or an AC adapter. Unlike conventional devices, the SMB135's high-efficiency operation eliminates large internal temperature rise and localized hot spot in handheld equipment.

Charge control includes qualification, trickle-charge, pre-charge, constant current/constant voltage, and termination/safety settings that are fully programmable via a serial I2C/SMBus making the device truly a flexible solution. Fast charge current level (one or five unit loads) can be set via I2C or an input pin (USB500/100). An Enable (EN) pin is also provided for suspending USB charging and allowing the device to work in parallel with AC charger, which may already be integrated into a PMIC device. In this case, the SMB135 does not allow current to flow back to the USB port.

The SMB135 offers a wide variety of features that protect the battery pack as well as the charger and input circuitry: over-current, under/over-voltage and thermal protection. Ultra-precise, 1% accurate, Kelvin-sensed ADOC™ technology allows accurate control of battery float voltage and improves battery capacity utilization. Status can be monitored via the serial port for charge state and fault conditions. In addition, one LED driver output can be used to signal charge status. As a protection mechanism, when the junction temperature approaches approximately 145°C, the PWM switcher will start to cut back on the duty cycle, to reduce current.

The SMB135 is available in a space-saving 1.3mm x 2.1mm uCSP™ package with lead-free balls and is rated over the -30°C to +85°C temperature range.

### SIMPLIFIED APPLICATIONS DRAWING

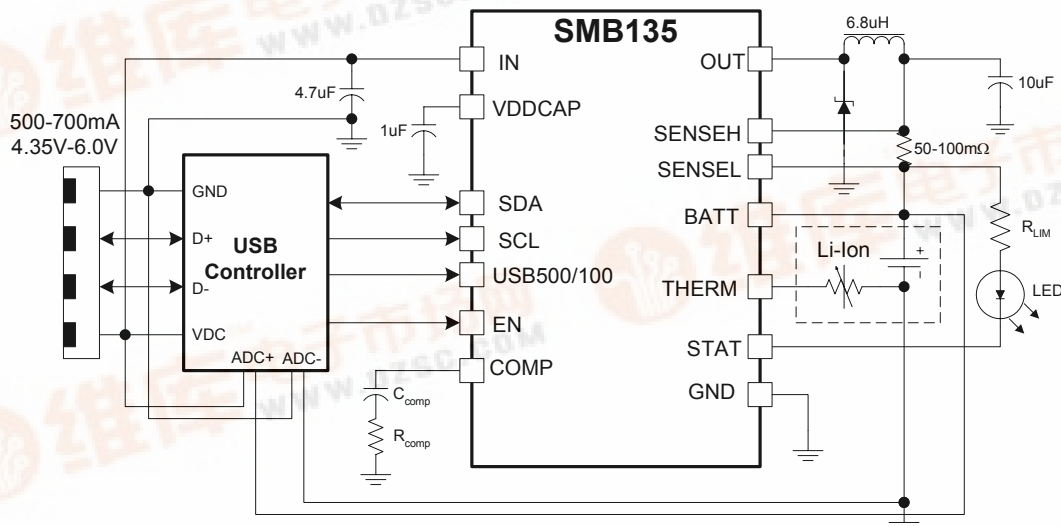

Figure 1 – Applications block diagram featuring the SMB135 programmable switch-mode battery charger.