

SKiiP 03NAC066V3

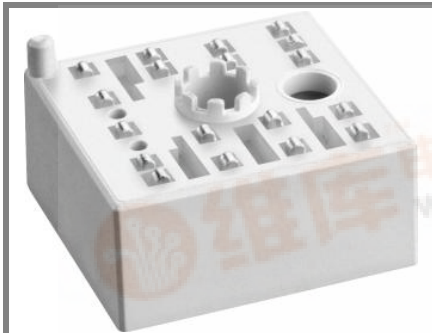

MiniSKiiP® 0

3-phase bridge rectifier +
3-phase bridge inverter

SKiiP 03NAC066V3

Target Data

Features

- Trench IGBTs
- Robust and soft freewheeling diodes in CAL technology
- Highly reliable spring contacts for electrical connections
- UL recognised file no. E63532

Typical Applications

- Inverter up to 5,6 kVA
- Typical motor power 3,0 kW

Remarks

- Case temperature limited to $T_C = 125^\circ\text{C}$ max.
- Product reliability results are valid for $T_j = 150^\circ\text{C}$
- SC data: $t_p \leq 6 \mu\text{s}$; $V_{GE} \leq 15 \text{ V}$; $T_j = 150^\circ\text{C}$; $V_{CC} = 360 \text{ V}$
- V_{CEsat} , $V_F =$ chip level value

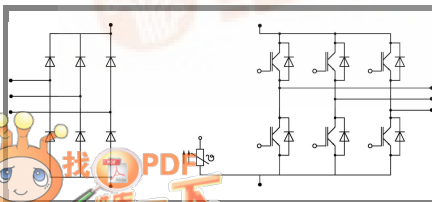

| Absolute Maximum Ratings | | $T_s = 25^\circ\text{C}$, unless otherwise specified | | |
|--------------------------|---|---|----------------------|--|
| Symbol | Conditions | Values | Units | |
| IGBT - Inverter | | | | |
| V_{CES} | | 600 | V | |
| I_C | $T_s = 25 (70)^\circ\text{C}$, $T_j = 150^\circ\text{C}$ | 24 (17) | A | |
| I_C | $T_s = 25 (70)^\circ\text{C}$, $T_j = 175^\circ\text{C}$ | 27 (20) | A | |
| I_{CRM} | $t_p = 1 \text{ ms}$ | 30 | A | |
| V_{GES} | | ± 20 | V | |
| Diode - Inverter | | | | |
| I_F | $T_s = 25 (70)^\circ\text{C}$, $T_j = 150^\circ\text{C}$ | 24 (16) | A | |
| I_F | $T_s = 25 (70)^\circ\text{C}$, $T_j = 175^\circ\text{C}$ | 28 (21) | A | |
| I_{FRM} | $t_p = 1 \text{ ms}$ | 30 | A | |
| Diode - Rectifier | | | | |
| V_{RRM} | | 800 | V | |
| I_F | $T_s = 70^\circ\text{C}$ | 35 | A | |
| I_{FSM} | $t_p = 10 \text{ ms}$, $\sin 180^\circ$, $T_j = 25^\circ\text{C}$ | 220 | A | |
| i^2t | $t_p = 10 \text{ ms}$, $\sin 180^\circ$, $T_j = 25^\circ\text{C}$ | 240 | A^2s | |
| I_{HRMS} | per power terminal (20 A / spring) | 20 | A | |
| T_j | IGBT, Diode | -40...+175 | $^\circ\text{C}$ | |
| T_{stg} | | -40...+125 | $^\circ\text{C}$ | |
| V_{isol} | AC, 1 min. | 2500 | V | |

| Characteristics | | $T_s = 25^\circ\text{C}$, unless otherwise specified | | | |
|---------------------------|--|---|-------------|-------------|------------------|
| Symbol | Conditions | min. | typ. | max. | Units |
| IGBT - Inverter | | | | | |
| $V_{CE(sat)}$ | $I_{Cnom} = 15 \text{ A}$, $T_j = 25 (150)^\circ\text{C}$ | 1,1 | 1,45 (1,65) | 1,85 (2,05) | V |
| $V_{GE(th)}$ | $V_{GE} = V_{CE}$, $I_C = 1 \text{ mA}$ | | 5,8 | | V |
| $V_{CE(TO)}$ | $T_j = 25 (150)^\circ\text{C}$ | | 0,9 (0,85) | 1 (0,9) | V |
| r_{CE} | $T_j = 25 (150)^\circ\text{C}$ | | 40 (57) | 60 (80) | $\text{m}\Omega$ |
| C_{ies} | $V_{CE} = 25 \text{ V}$, $V_{GE} = 0 \text{ V}$, $f = 1 \text{ MHz}$ | | 0,86 | | nF |
| C_{oes} | $V_{CE} = 25 \text{ V}$, $V_{GE} = 0 \text{ V}$, $f = 1 \text{ MHz}$ | | 0,18 | | nF |
| C_{res} | $V_{CE} = 25 \text{ V}$, $V_{GE} = 0 \text{ V}$, $f = 1 \text{ MHz}$ | | 0,12 | | nF |
| R_{CC+EE} | spring contact-chip $T_s = ()^\circ\text{C}$ | | | | $\text{m}\Omega$ |
| $R_{th(j-s)}$ | per IGBT | | 1,8 | | K/W |
| $t_{d(on)}$ | under following conditions | | 20 | | ns |
| t_r | $V_{CC} = 300 \text{ V}$, $V_{GE} = \pm 15 \text{ V}$ | | 30 | | ns |
| $t_{d(off)}$ | $I_{Cnom} = 15 \text{ A}$, $T_j = 150^\circ\text{C}$ | | 155 | | ns |
| t_f | $R_{Gon} = R_{Goff} = 22 \Omega$ | | 45 | | ns |
| $E_{on} (E_{off})$ | inductive load | | 0,6 (0,5) | | mJ |
| Diode - Inverter | | | | | |
| $V_F = V_{EC}$ | $I_F = 15 \text{ A}$, $T_j = 25 (150)^\circ\text{C}$ | | 1,4 (1,4) | 1,7 (1,7) | V |
| $V_{(TO)}$ | $T_j = 25 (150)^\circ\text{C}$ | | 1 (0,9) | 1,1 (1) | V |
| r_T | $T_j = 25 (150)^\circ\text{C}$ | | 27 (34) | 40 (47) | $\text{m}\Omega$ |
| $R_{th(j-s)}$ | per diode | | 2,5 | | K/W |
| I_{RRM} | under following conditions | | 20 | | A |
| Q_{rr} | $I_{Fnom} = 15 \text{ A}$, $V_R = 300 \text{ V}$ | | 1,8 | | μC |
| E_{rr} | $V_{GE} = 0 \text{ V}$, $T_j = 150^\circ\text{C}$ | | 0,5 | | mJ |
| | $di_F/dt = 930 \text{ A}/\mu\text{s}$ | | | | |
| Diode - Rectifier | | | | | |
| V_F | $I_{Fnom} = 15 \text{ A}$, $T_j = 25^\circ\text{C}$ | | 1,1 | | V |
| $V_{(TO)}$ | $T_j = 150^\circ\text{C}$ | | 0,8 | | V |
| r_T | $T_j = 150^\circ\text{C}$ | | 20 | | $\text{m}\Omega$ |
| $R_{th(j-s)}$ | per diode | | 1,5 | | K/W |
| Temperature Sensor | | | | | |
| R_{ts} | 3 %, $T_r = 25 (100)^\circ\text{C}$ | | 1000(1670) | | Ω |
| Mechanical Data | | | | | |
| w | | | 21,5 | | g |
| M_s | Mounting torque | 2 | | 2,5 | Nm |



SKiiP 03NAC066V3

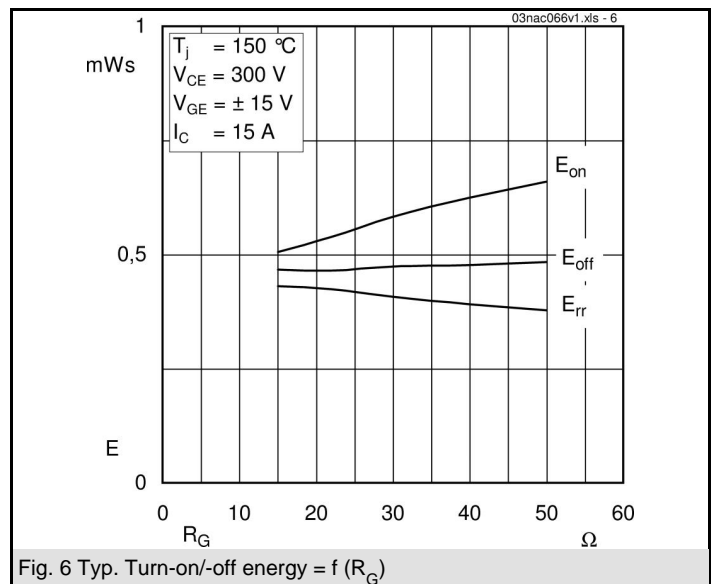
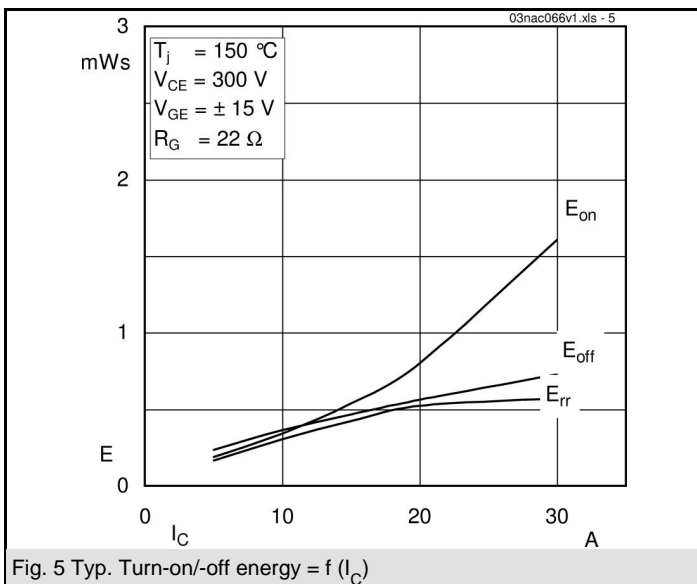
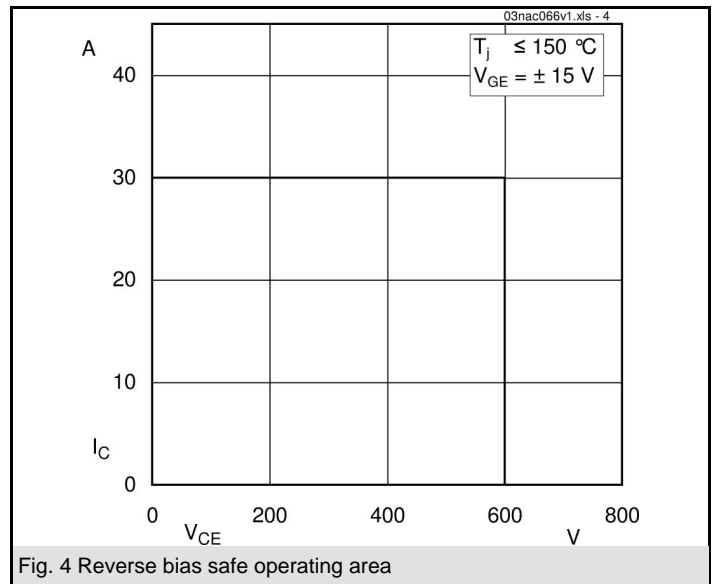
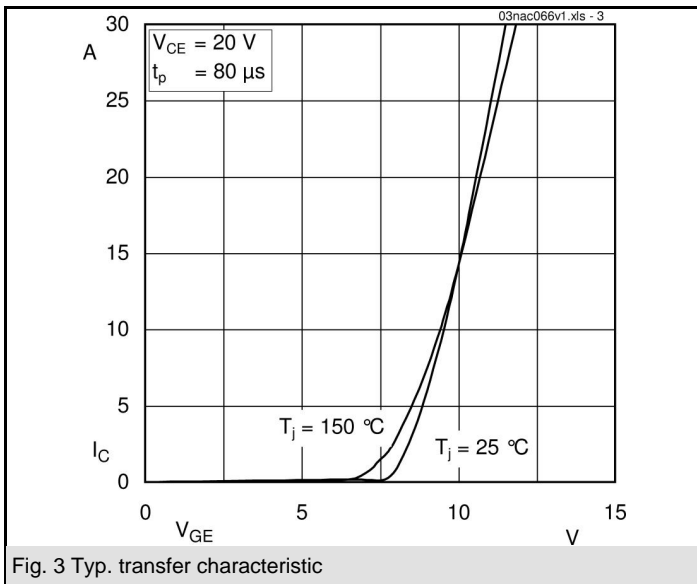
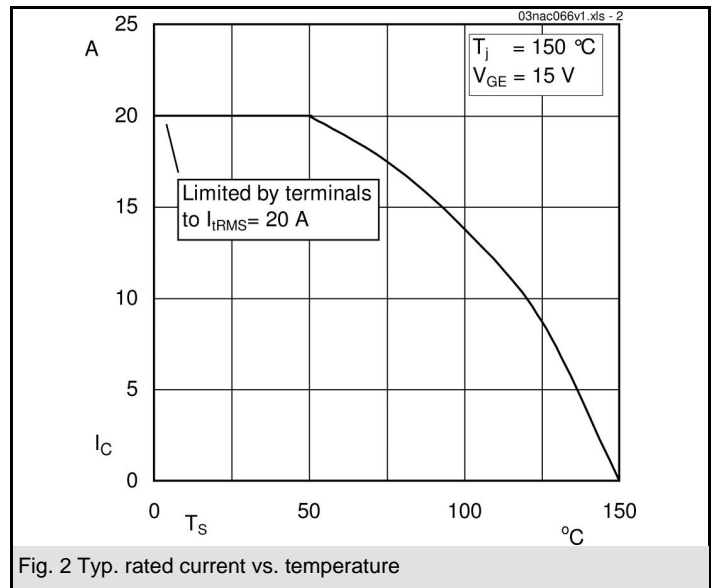
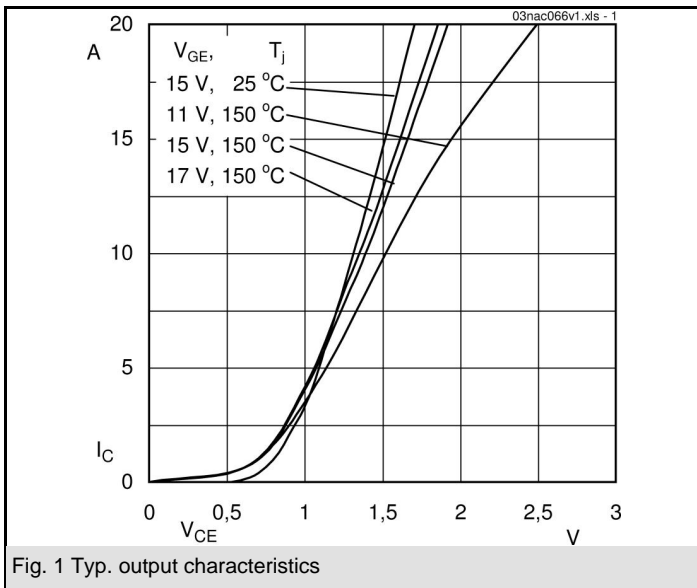

SKiiP 03NAC066V3

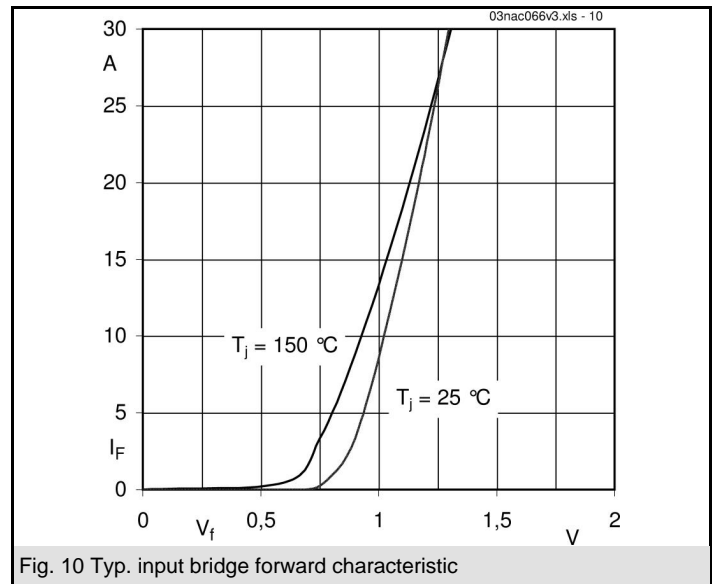
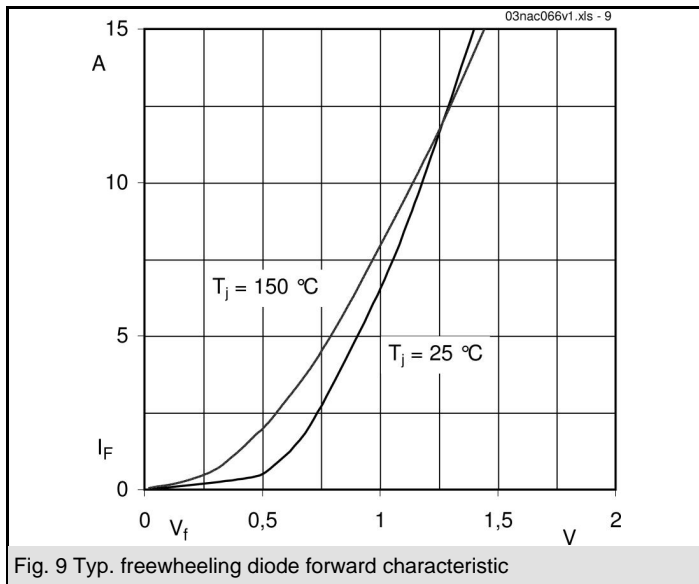
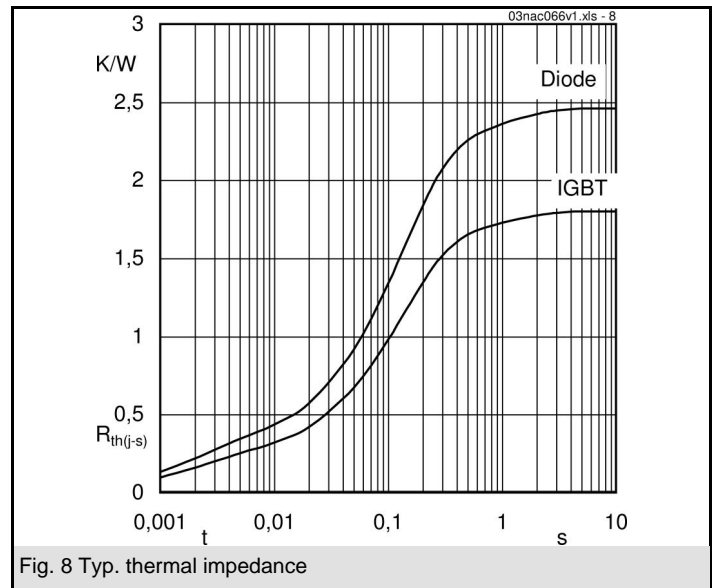
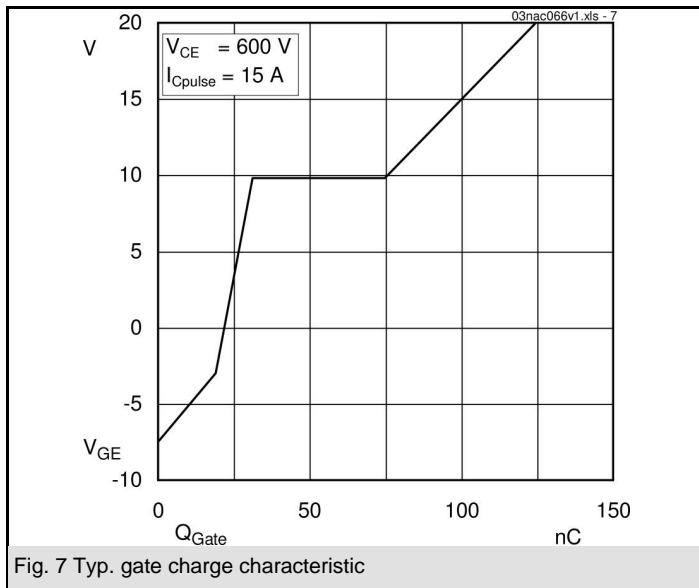

SKiiP 03NAC066V3

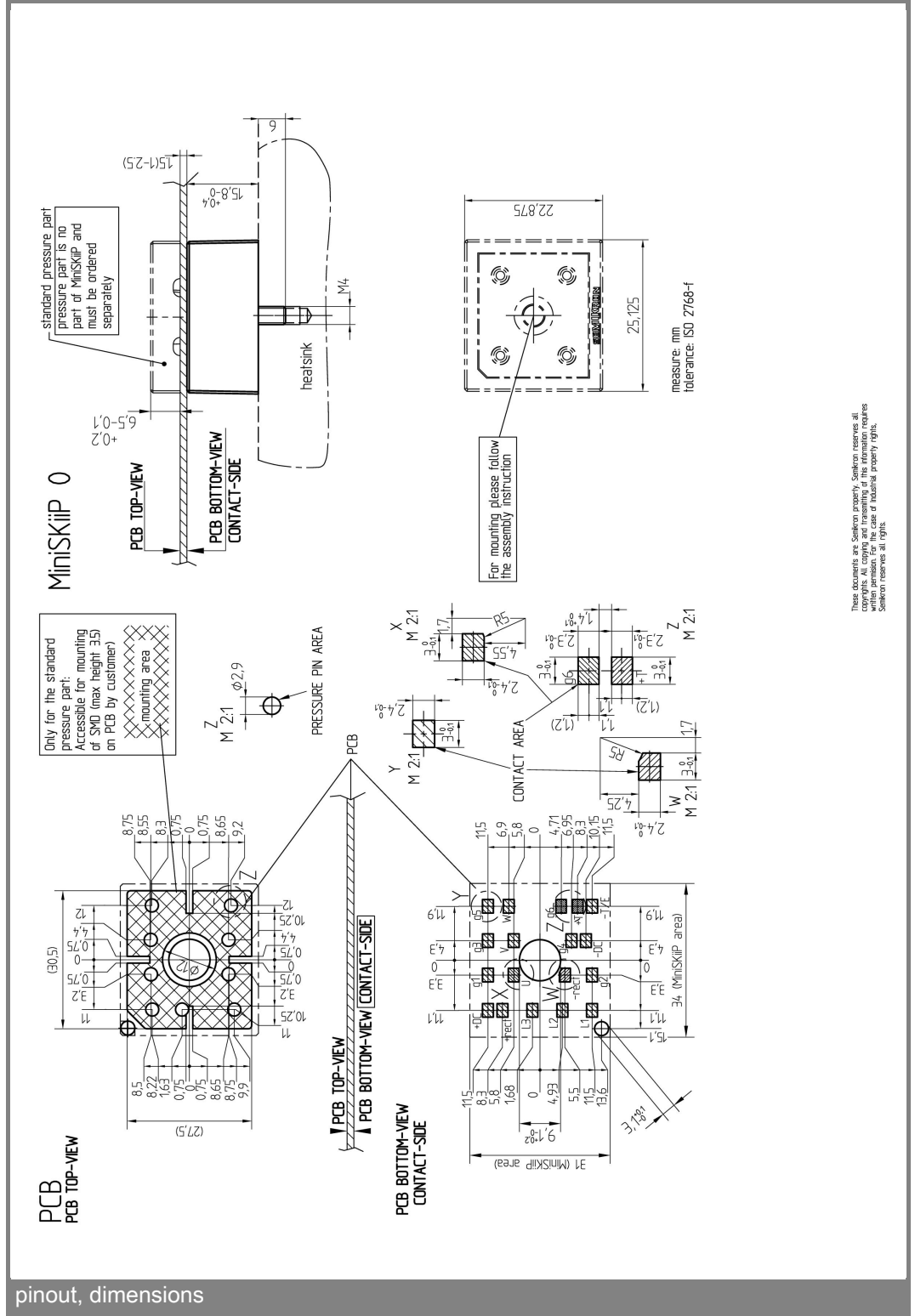
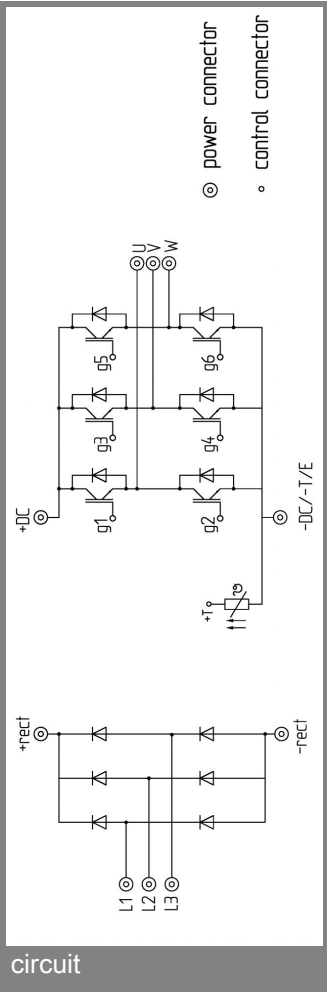

These documents are customer property. Customer reserves all copyrights. All copies and transmissions of this information requires written permission. For the case of industrial property rights, Solecorn reserves all rights.

This is an electrostatic discharge sensitive device (ESDS), international standard IEC 60747-1, Chapter IX.

This technical information specifies semiconductor devices but promises no characteristics. No warranty or guarantee expressed or implied is made regarding delivery, performance or suitability.