

SKiiP 03NAC066V1



3-phase bridge rectifier +
3-phase bridge inverter

SKiiP 03NAC066V1

Target Data

Features

- Trench IGBTs
- Robust and soft freewheeling diodes in CAL technology
- Highly reliable spring contacts for electrical connections
- UL recognised file no. E63532

Typical Applications

- Inverter up to 5,6 kVA
- Typical motor power 3,0 kW

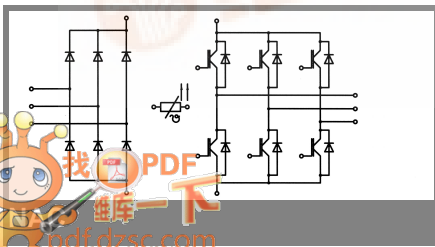

Absolute Maximum Ratings		$T_s = 25\text{ }^\circ\text{C}$, unless otherwise specified	
Symbol	Conditions	Values	Units
IGBT - Inverter, Chopper			
V_{CES}		600	V
I_C	$T_s = 25\text{ (70) }^\circ\text{C}$	22 (17)	A
I_{CRM}	$T_s = 25\text{ (70) }^\circ\text{C}$, $t_p \leq 1\text{ ms}$	23 (19)	A
V_{GES}		± 20	V
T_j		- 40 ... + 175	$^\circ\text{C}$
Diode - Inverter, Chopper			
I_F	$T_s = 25\text{ (70) }^\circ\text{C}$	20 (15)	A
I_{FRM}	$T_s = 25\text{ (70) }^\circ\text{C}$, $t_p \leq 1\text{ ms}$	22 (18)	A
T_j		- 40 ... + 175	$^\circ\text{C}$
Diode - Rectifier			
V_{RRM}		800	V
I_F	$T_s = 70\text{ }^\circ\text{C}$	35	A
I_{FSM}	$t_p = 10\text{ ms}$, $\sin 180^\circ$, $T_j = 25\text{ }^\circ\text{C}$	220	A
i^2t	$t_p = 10\text{ ms}$, $\sin 180^\circ$, $T_j = 25\text{ }^\circ\text{C}$	240	A^2s
T_j		- 40 ... + 150	$^\circ\text{C}$
I_{RMS}	per power terminal (20 A / spring)	20	A
T_{stg}	$T_{op} \leq T_{stg}$	- 40 ... + 125	$^\circ\text{C}$
V_{isol}	AC, 1 min.	2500	V

Characteristics		$T_s = 25\text{ }^\circ\text{C}$, unless otherwise specified			
Symbol	Conditions	min.	typ.	max.	Units
IGBT - Inverter, Chopper					
V_{CEsat}	$I_C = 15\text{ A}$, $T_j = 25\text{ (125) }^\circ\text{C}$	1,1	1,45 (1,65)	1,85 (2,05)	V
$V_{GE(th)}$	$V_{GE} = V_{CE}$, $I_C = 1\text{ mA}$		5,8		V
$V_{CE(TO)}$	$T_j = 25\text{ (150) }^\circ\text{C}$		0,9 (0,85)	1 (0,9)	V
r_T	$T_j = 25\text{ (150) }^\circ\text{C}$		40 (57)	60 (80)	$\text{m}\Omega$
C_{ies}	$V_{CE} = 25\text{ V}$, $V_{GE} = 0\text{ V}$, $f = 1\text{ MHz}$		0,86		nF
C_{oes}	$V_{CE} = 25\text{ V}$, $V_{GE} = 0\text{ V}$, $f = 1\text{ MHz}$		0,18		nF
C_{res}	$V_{CE} = 25\text{ V}$, $V_{GE} = 0\text{ V}$, $f = 1\text{ MHz}$		0,12		nF
$R_{th(j-s)}$	per IGBT		1,78		K/W
$t_{d(on)}$	under following conditions		20		ns
t_r	$V_{CC} = 300\text{ V}$, $V_{GE} = \pm 15\text{ V}$		30		ns
$t_{d(off)}$	$I_C = 15\text{ A}$, $T_j = 125\text{ }^\circ\text{C}$		155		ns
t_f	$R_{Gon} = R_{Goff} = 22\text{ }\Omega$		40		ns
E_{on}	inductive load		0,55		mJ
E_{off}			0,24		mJ
Diode - Inverter, Chopper					
$V_F = V_{EC}$	$I_F = 15\text{ A}$, $T_j = 25\text{ (125) }^\circ\text{C}$		1,4 (1,4)	1,7 (1,7)	V
$V_{(TO)}$	$T_j = 25\text{ (150) }^\circ\text{C}$		1 (0,9)	1,1 (1)	V
r_T	$T_j = 25\text{ (150) }^\circ\text{C}$		27 (33)	40 (47)	$\text{m}\Omega$
$R_{th(j-s)}$	per diode		2,46		K/W
I_{RRM}	under following conditions		20		A
Q_{rr}	$I_F = 15\text{ A}$, $V_R = 300\text{ V}$		1,8		μC
E_{rr}	$V_{GE} = 0\text{ V}$, $T_j = 125\text{ }^\circ\text{C}$		0,45		mJ
	$di_F/dt = 930\text{ A}/\mu\text{s}$				
Diode - Rectifier					
V_F	$I_F = 15\text{ A}$, $T_j = 25\text{ }^\circ\text{C}$		1,1		V
$V_{(TO)}$	$T_j = 150\text{ }^\circ\text{C}$		0,8		V
r_T	$T_j = 150\text{ }^\circ\text{C}$		20		$\text{m}\Omega$
$R_{th(j-s)}$	per diode		1,5		K/W
Temperature Sensor					
R_{ts}	3 %, $T_r = 25\text{ (100) }^\circ\text{C}$		1000(1670)		Ω
Mechanical Data					
w			35		g
M_s	Mounting torque	2		2,5	Nm



SKiiP 03NAC066V1

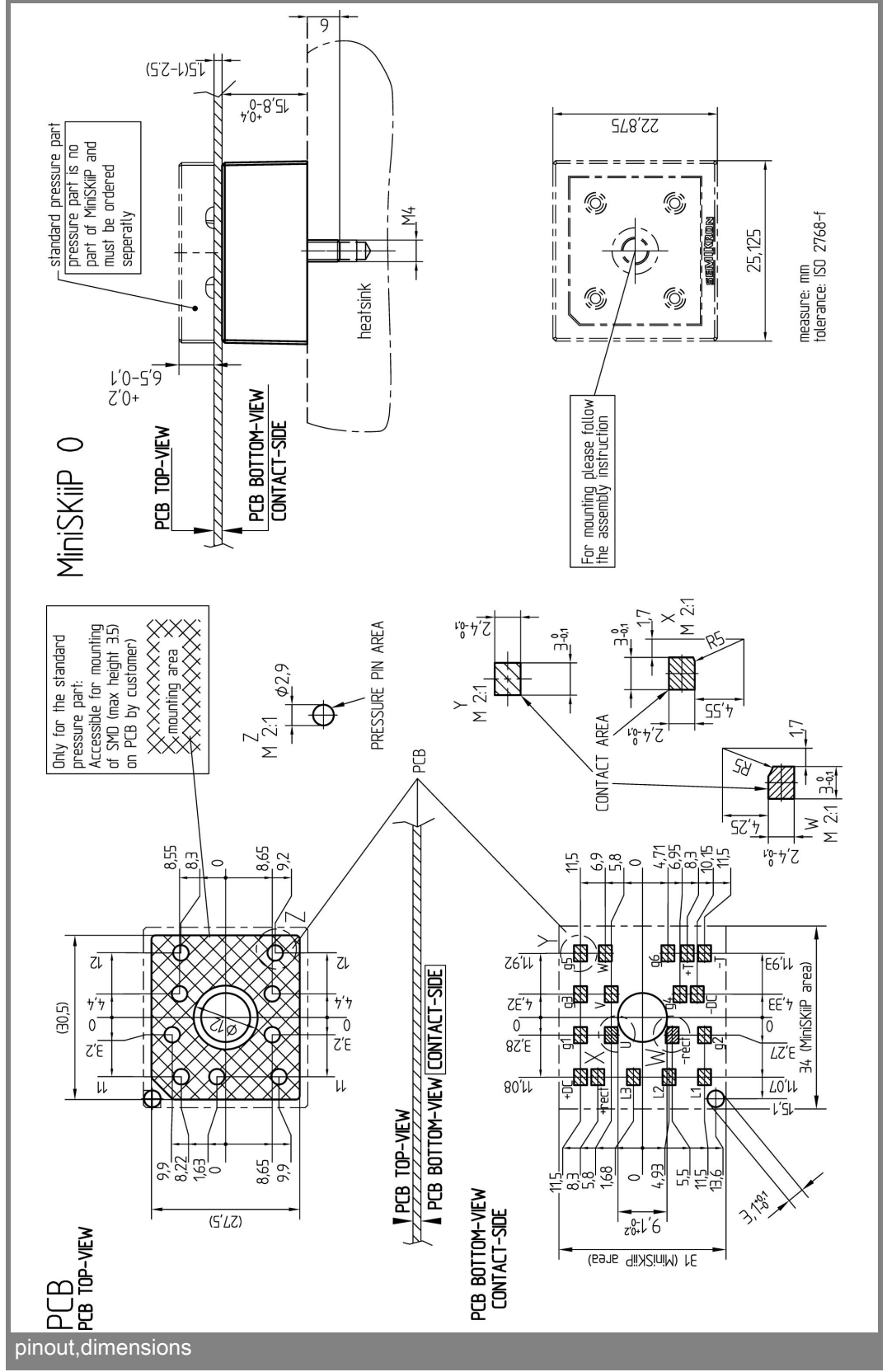
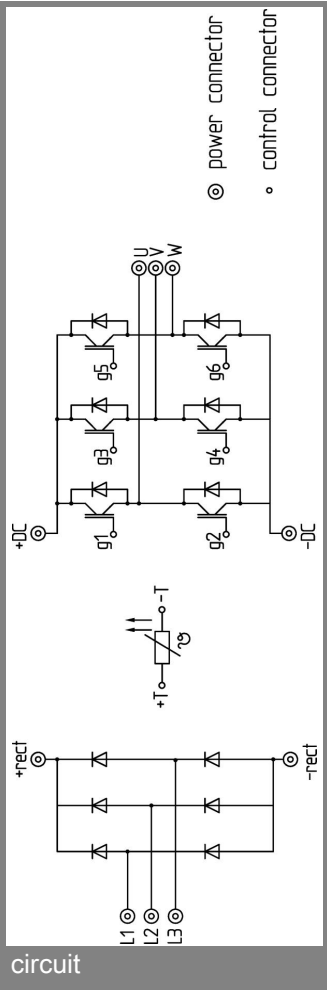

This is an electrostatic discharge sensitive device (ESDS), international standard IEC 60747-1, Chapter IX.

This technical information specifies semiconductor devices but promises no characteristics. No warranty or guarantee expressed or implied is made regarding delivery, performance or suitability.