

SKiIP 01AC066V1

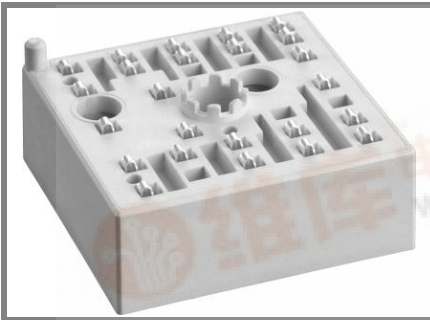

MiniSKiIP[®] 1

3-phase bridge inverter

SKiIP 01AC066V1

Target Data

Features

- Trench IGBT's
- Robust and soft freewheeling diodes in CAL technology
- Highly reliable spring contacts for electrical connections
- UL recognised file no. E63532

Typical Applications

- Inverter up to 6,3 kVA
- Typical motor power 4,0 kW

Absolute Maximum Ratings		$T_s = 25\text{ }^\circ\text{C}$, unless otherwise specified	
Symbol	Conditions	Values	Units
IGBT - Inverter			
V_{CES}		600	V
I_C	$T_s = 25\text{ (70) }^\circ\text{C}$		A
I_{CRM}	$T_s = 25\text{ (70) }^\circ\text{C}$, $t_p \leq 1\text{ ms}$		A
V_{GES}		± 20	V
T_j		- 40 ... + 150	$^\circ\text{C}$
Diode - Inverter			
I_F	$T_s = 25\text{ (70) }^\circ\text{C}$		A
I_{FRM}	$T_s = 25\text{ (70) }^\circ\text{C}$, $t_p \leq 1\text{ ms}$		A
T_j		- 40 ... + 150	$^\circ\text{C}$
I_{RMS}	per power terminal (20 A / spring)	40	A
T_{stg}	$T_{op} \leq T_{stg}$	- 40 ... + 125	$^\circ\text{C}$
V_{isol}	AC, 1 min.	2500	V

Characteristics		$T_s = 25\text{ }^\circ\text{C}$, unless otherwise specified			
Symbol	Conditions	min.	typ.	max.	Units
IGBT - Inverter					
V_{CEsat}	$I_C = 20\text{ A}$, $T_j = 25\text{ (125) }^\circ\text{C}$		2 (2,2)	2,5 (2,7)	V
$V_{GE(th)}$	$V_{GE} = V_{CE}$, $I_C = 0,5\text{ mA}$	3	4	5	V
$V_{CE(TO)}$	$T_j = 25\text{ (125) }^\circ\text{C}$		1,2 (1,1)	1,3 (1,2)	V
r_T	$T_j = 25\text{ (125) }^\circ\text{C}$		40 (55)	60 (75)	m Ω
C_{ies}	$V_{CE} = 25\text{ V}$, $V_{GE} = 0\text{ V}$, $f = 1\text{ MHz}$		1,1		nF
C_{oes}	$V_{CE} = 25\text{ V}$, $V_{GE} = 0\text{ V}$, $f = 1\text{ MHz}$		0,2		nF
C_{res}	$V_{CE} = 25\text{ V}$, $V_{GE} = 0\text{ V}$, $f = 1\text{ MHz}$		0,1		nF
$R_{th(j-s)}$	per IGBT		1,25		K/W
$t_{d(on)}$	under following conditions		20		ns
t_r	$V_{CC} = 300\text{ V}$, $V_{GE} = \pm 15\text{ V}$		30		ns
$t_{d(off)}$	$I_C = 20\text{ A}$, $T_j = 125\text{ }^\circ\text{C}$		170		ns
t_f	$R_{Gon} = R_{Goff} = 30\text{ }^\circ\Omega$		20		ns
E_{on}	inductive load		0,7		mJ
E_{off}			0,4		mJ
Diode - Inverter					
$V_F = V_{EC}$	$I_F = 20\text{ A}$, $T_j = 25\text{ (125) }^\circ\text{C}$		1,6 (1,6)	1,9 (1,9)	V
$V_{(TO)}$	$T_j = 25\text{ (125) }^\circ\text{C}$		1 (0,9)	1,1 (1)	V
r_T	$T_j = 25\text{ (125) }^\circ\text{C}$		30 (33)	40 (47)	m Ω
$R_{th(j-s)}$	per diode		2,2		K/W
I_{RRM}	under following conditions		27		A
Q_{rr}	$I_F = 20\text{ A}$, $V_R = 300\text{ V}$		2,3		μC
E_{rr}	$V_{GE} = 0\text{ V}$, $T_j = 125\text{ }^\circ\text{C}$ $di_F/dt = 1350\text{ A}/\mu\text{s}$		0,4		mJ
Temperature Sensor					
R_{ts}	3 %, $T_r = 25\text{ (100) }^\circ\text{C}$		1000(1670)		Ω
Mechanical Data					
m			35		g
M_s	Mounting torque	2		2,5	Nm

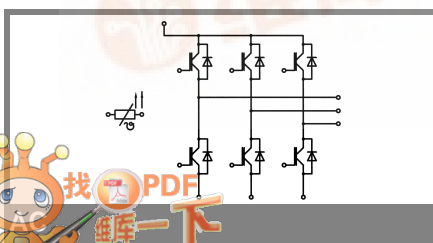

SKiiP 01AC066V1

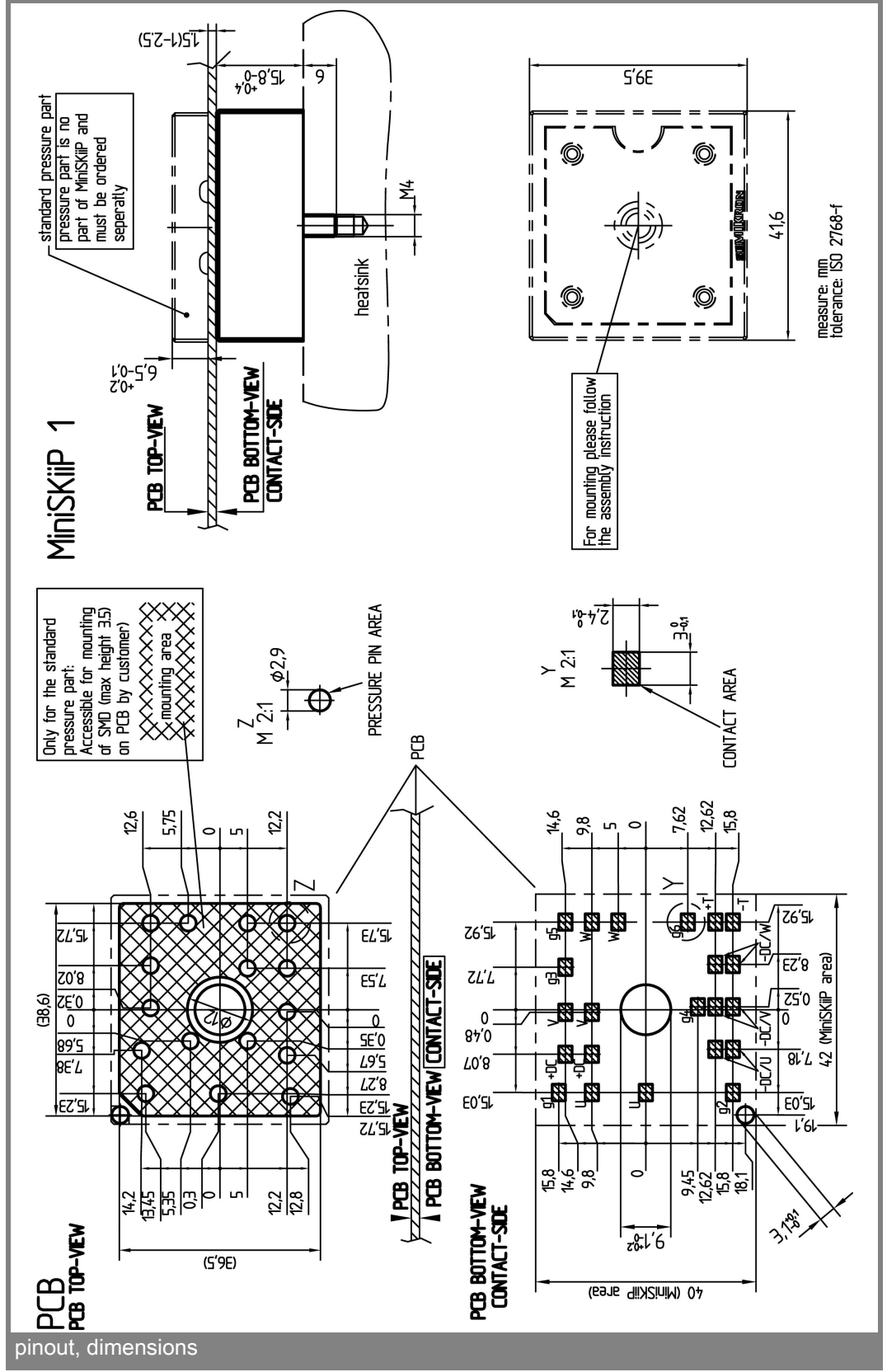
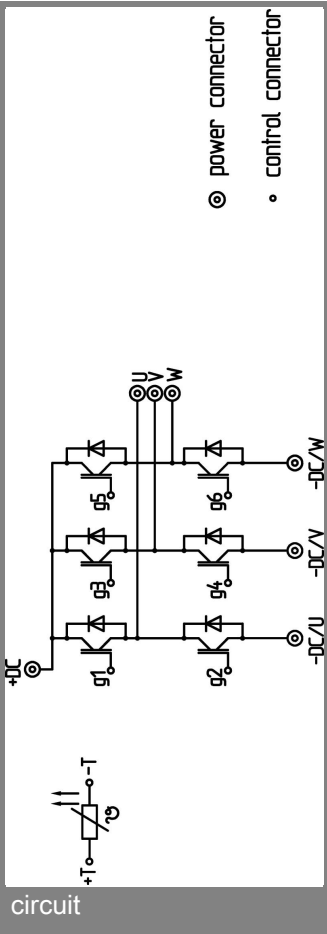

This is an electrostatic discharge sensitive device (ESDS), international standard IEC 60747-1, Chapter IX.

This technical information specifies semiconductor devices but promises no characteristics. No warranty or guarantee expressed or implied is made regarding delivery, performance or suitability.