

Surface Mount Crystal Oscillators -

Seiko Epson

SG615 Series



Features

- Frequency range 1.025MHz to 125.00MHz
- World's best selling SMD oscillator stocked in depth
- Output Enable/Disable now standard
- Excellent specification and price

Specifications of low and medium frequency range

Item	Symbol	SG615P	SG615PTJ Specifications	SG615PH	Remarks
Output frequency range	f_0	1.0250MHz to 26.0000MHz	26.0001MHz to 66.6667MHz		
Power source voltage	Max. supply voltage	V_{DD} -GND	-0.3V to +7.0V		
	Operating voltage	V_{DD}	5.0V \pm 0.5V		
Temperature range	Storage temp.	T_{STG}	-55 $^{\circ}$ V to +125 $^{\circ}$ C		Stored as bare product after unpacking
	Operating temp.	T_{OPR}	-10 $^{\circ}$ C to 70 $^{\circ}$ C (-40 $^{\circ}$ C to 85 $^{\circ}$ C)		
Soldering condition	T_{SOL}	Twice at under 260 $^{\circ}$ C within 10sec. or under 230 $^{\circ}$ C within 3mins.			
Frequency stability	$\Delta f/f_0$		B: \pm 50ppm C: \pm 100ppm		B type is possible up to 55MHz
Current consumption	I_{OP}	23mA MAX.	35mA MAX.		No load condition
Duty	CMOS	40% to 60%	-	40% to 60%	C-MOS load : 1.2 V_{DD}
	TTL level	$T_{W/T}$	45% to 55%	-	TTL load : 1.4V
Output voltage	V_{OH} (I_{OH})	V_{DD} -0.4V MIN. -400 μ A	24V MIN. -400 μ A	V_{DD} -0.4V MIN -4mA	
	V_{OL} (I_{OL})		0.4V MAX.		
Output load condition (fan out)	C-MOS	CL	50pF MAX.	50pF MAX.	
Output enable/disable input voltage	TTL	N	10TTL MAX.	5TTL MAX.	
Output disable current	V_{IH}	20V MIN	3.5V MIN.	2.0V MIN.	I_{IH} =1 μ A MAX. (OE= V_{DD})
	V_{IL}	0.8V MIN	1.5V MAX.	0.8V MIN.	I_{IL} =-100 μ A MIN. (OE=GND) I_{IL} =-500 μ A MIN. (OE=GND) PTJ OE=GND
Output rise time	C-MOS level	T_{TLH}	8nsec. MAX.	7nsec. MAX	C-MOS load : 20% to 80% V_{DD}
Output fall time	TTL level		5nsec. MAX.	-	TTL load : 0.4V to 2.4V
	C-MOS level	T_{TLH}	8nsec. MAX.	7nsec. MAX	C-MOS load : 80% to 20% V_{DD}
Oscillation start up time	TTL level		5nsec. MAX.	-	TTL load : 2.4V to 0.4V
	t_{OSC}	4msec. MAX.	10msec. MAX.		Time at 4.5V to be 0sec.
Aging	f_a		\pm 5ppm/year MAX.		T_a =25 $^{\circ}$ C, V_{DD} =5V, first year
Shock resistance	S.R.		\pm 20ppm MAX.		3-times of drop test on a hard board from 75cm height or excitation test with 300G x 0.3 x 1/2 sine wave in 3-directions

Note • Unless otherwise stated, characteristics (specifications) shown in the above table are based on the rated operating temperature and voltage condition • External by-pass capacitor is required.

Frequency Table

Model	Frequency 1MHz	26MHz	40MHz	67MHz	125MHz
SG615P	—	—	—	—	—
SG615PTJ	—	—	—	—	—
SG615PH	—	—	—	—	—
SG615PCV	—	—	—	—	—



Surface Mount Crystal Oscillators - Seiko Epson

SG615 Series Continued Dimensions (mm)

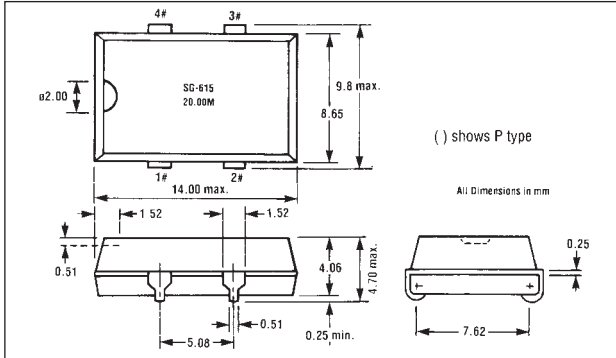

Recommended Soldering Pattern (mm)

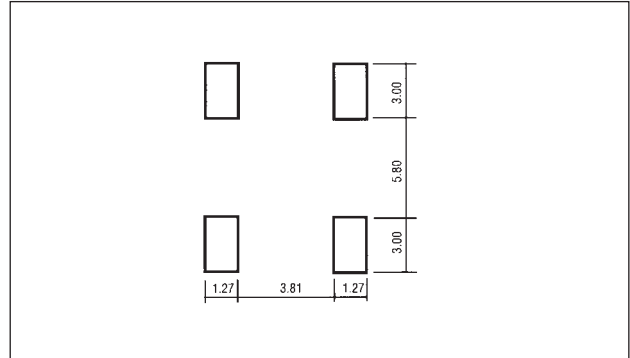

Specifications of high frequency range

Item	Symbol	Specifications SG615 PCV	Remarks	
Output frequency range	f_o	40.0001MHz to 80.0000MHz 40.0001MHz to 125.0000MHz	$V_{DD}=2.7V$ to 5.5V $V_{DD}=4.5V$ to 5.5V	
Power source voltage	Max. supply voltage Operating voltage	$V_{DD}-GND$ V_{DD}	-0.5V to +7.0V 2.7V \pm 5.5V	
Temperature range	Storage temp. Operating temp.	T_{ST} T_{OFR}	-55°C to -125°C -10°C to +70°C	Stored as bare product after unpacking
Soldering condition	T_{SOL}	Twice at under 260°C within 10sec. or under 230°C within 3mins		
Frequency stability	$\Delta f/f_o$	C: \pm 100ppm	-10°C to +70°C, V_{DD} : 2.7V to 5.5V	
Current consumption	I_{OP}	50mA MAX.	No load condition	
Duty	T_w/T	35% to 60%	$1/2 V_{DD}$	
Output voltage	V_{OH} (I_{OH}) V_{OL} (I_{OL})	$V_{DD}-0.5V$ -16mA 0.4V MAX. 16mA		
Output load condition(fan out)	CL	25pF MAX. 15pF MAX.	$V_{DD}=4.5V$ to 5.5V $V_{DD}=2.7V$ to 4.5V	
Output enable/disable input voltage	V_{IH} V_{IL}	0.7 V_{DD} MIN. 0.2 V_{DD} MAX.		
Output disable current	I_{OE}	27mA MAX.	OE=GND	
Output rise time	T_{TLH}	4nsec.	20% to 80% V_{DD}	
Output fall time	T_{TLH}		80% to 20% V_{DD}	
Oscillation start up time	t_{OSC}	10msec. MAX.	Time at 2.7V to be 0sec.	
Aging	fa	\pm 5ppm/year MAX.	$T_a=25^\circ C$, first year	
Shock resistance	S.R.	\pm 20ppm MAX.	Drop test of 3 times on a hard board from 75mm height or excitation test with 3000G x 0.3ms x 1/2sine wave in 3 directions	

Note • Unless otherwise stated, characteristics (specifications) shown in the above table are based on the rated operating temperature and voltage condition • External by-pass capacitor is required.

$V_{DD}=5V \pm 0.25V$, Load: $CL \leq 50pF$, $T_a = -10$ to $70^\circ C$, Refer to output waveform chart of 386 CPU)

Item	Symbol	Min		Max		Min		Max		nS	
CLK high time	t2a	9		8		7		6.25			2V level
CLK high time	t2b	5		5		4		4.5			Under 45MHz: $V_{DD}-0.8V$ level Under 45MHz: 3.7V level
CLK low time	t3a	9		8		7		6.25			2V level
CLK low time	t3b	7		6		5		4.5			2V level
CLK fall time	t4		8		8		7		4		Under 4.5MHz: $V_{DD}-0.8$ to +0.8V Under 45MHz: 3.7V to 0.8V
CLK rise time	t5		9		9		7		4		Over 4.5MHz: 0.8 V_{DD} to +0.8V Over 45MHz: 0.8 to 3.7V

Surface Mount Crystal Oscillators -

Seiko Epson SG615 SERIES CONTINUED

SG615 Standard Low Frequency Series Stock Numbers

Frequency (MHz)	SG615 -40°C +85°C	SG615P -40°C +85°C	SG615 -10°C +70°C	SG615P -10°C +70°C
1.8432		BF0184A		DO0184A
2.4576	AE0245A			DO0245A
3.579545	AE0357A			
3.6864		BF0368A	DN0368A	D00368A
4.00	AE0400A	BF0400A	DN0400A	
4.096		BF0409A		
4.9152		BF0491A		DO0491A
5.00		BF0500A		DO0500A
5.0688			DN0506A	
6.00	AE0600A			
6.144	AE0614A		DN0614A	
7.3728	AE0737A			
8.00	AE08000A	DF0800A	DN08000A	DO0800A
9.8304		BF0983A		
10.00		BF1000A	DN1000A	DO1000A
11.000	AE1100A	BF1100A		
11.0592		BF1105A		
12.00	AE1200A	BF1200A		
12.288		BF1228A		
14.31818	AE1431A	BF1431A		
14.7456	AE1474A	BF1474A		
15.00				DO1500A
16.00	AE1600A	BF1600A		DO1600A
16.384		BF1638A	DN16384A	
16.388	AE16388A			
19.6608		BF1966A		
20.00		BF2000A		DO2000A
24.00	AE2400A	BF2400A		DO2400A
24.576		BF2457A		
25.00	AE2500A	BF2500A		DO2500A

SG615 Standard High Frequency Series Stock Numbers

Frequency (MHz)	SG-615 -40°C +85°C	SG-615PH -20°C +70°C	SG-615T -40°C +85°C	SG-615PTJ -20°C +70°C
27.00			AG2700A	
32.00		DS3200A		
33.333			AG3333A	
40.00	AF4000A	DS4000A		EK4000A
48.00		DS4800A		
50.00	AF5000A	DS5000A		EK5000A
60.00		DS6000A		EK6000A
64.00		DS64000A		
66.00		DS6600A		
66.66		DS6666A		

Waveform Chart of 386 CPU

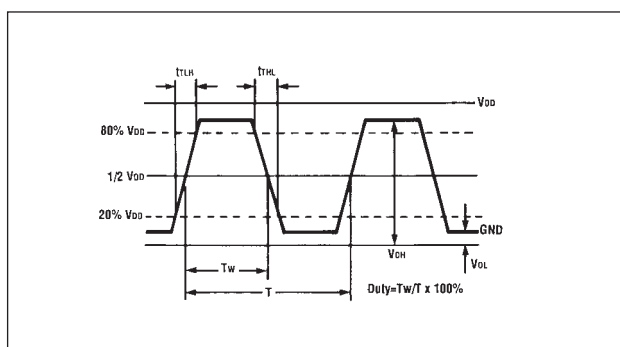

Waveform chart of SG615PTJ

