

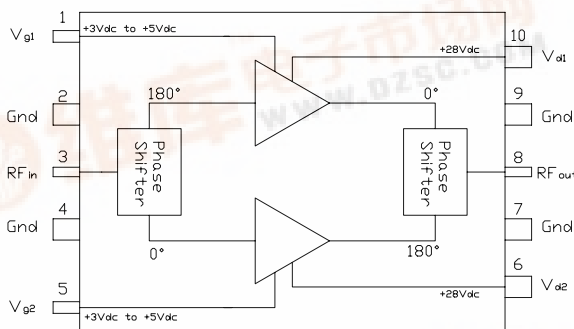

Product Description

The **SDM-08060** 60W power module is an impedance matched, single stage, push-pull Class AB amplifier module suitable for use as a power amplifier driver or output stage. It is a drop in, no tune, solution for high power applications requiring high efficiency, excellent linearity, and unit to unit repeatability.

Functional Block Diagram



Advance

SDM-08060

869-894 MHz Class AB
60W Power Amplifier Module

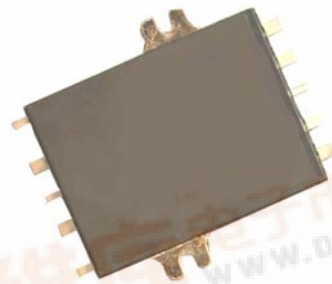

Product Features

- 50 Ω RF impedance
- 60W Output P_{1dB}
- 28 Volt Operation
- High Gain: 17 dB Typical
- High Efficiency

Application

- Base Station PA driver
- Repeater
- CDMA
- GSM / EDGE

Key Specifications

Parameter	Description: Test Conditions $Z_{in} = Z_{out} = 50\Omega$, $V_{DD} = 28.0V$, $I_{D1} = 300mA$, $I_{D2} = 300mA$, $T_{Flange} = 25^{\circ}C$	Unit	Min.	Typ.	Max.
Frequency	Frequency of Operation	MHz	869	-	894
P _{1dB}	Output Power at 1dB Compression, 881 MHz	W	60	65	-
Gain	Gain at 12W CDMA Output (Single Carrier IS-95), 881MHz	dB	16	17	-
Gain Flatness	Peak to Peak Gain Variation, 869 - 894MHz	dB	-	0.3	.5
Efficiency	Drain Efficiency at 60W PEP, 880MHz and 881MHz	%	32	34	-
IRL	Input Return Loss 12W CW Output Power, 869 - 894MHz	dB	-	-15	-12
IMD	3rd Order IMD Product, 60W PEP, 880MHz and 881MHz	dBc	-	-31	-28
Delay	Signal Delay from Pin 3 to Pin 8	nS	-	4.0	-
Phase Linearity	Deviation from Linear Phase (Peak to Peak)	Deg	-	0.5	-

The information provided herein is believed to be reliable at press time. Sirenza Microdevices assumes no responsibility for inaccuracies or omissions. Sirenza Microdevices assumes no responsibility for the use of this information, and all such information shall be entirely at the user's own risk. Prices and specifications are subject to change without notice. No patent rights or licenses to any of the circuits described herein are implied or granted to any third party. Sirenza Microdevices does not authorize or warrant any Sirenza Microdevices product for use in life-support devices and/or systems.



Pin Out Description

Pin #	Function	Description
1,5	V _{GS}	This is the gate bias for the one side of the amplifier module.
2,4,7,9	Ground	Module Topside ground.
3	RF Input	Module RF input. This pin is internally connected to DC ground. Do not apply DC voltages to the RF leads. Care must be taken to protect against video transients that may damage the active devices.
6,10	V _{DD}	This is the drain feed for the amplifier module. See Note 1.
8	RF Output	Module RF output. This pin is internally connected to DC ground. Do not apply DC voltages to the RF leads. Care must be taken to protect against video transients that may damage the active devices.
Flange	Gnd	Exposed area on the bottom side of the package provides electrical ground and a thermal transfer path for the device. Proper mounting insures optimal performance and the highest reliability. See Sirenza applications note:AN-054 Detailed Installation Instructions for Power Modules.

Simplified Device Schematic

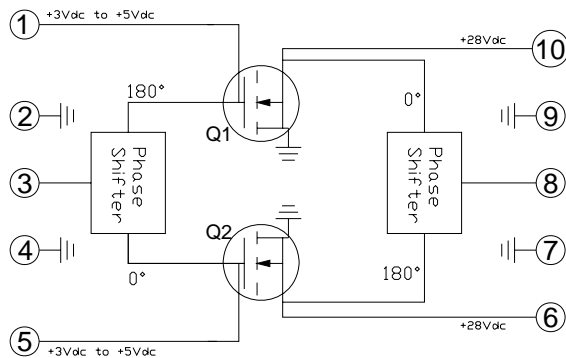

Case Flange = Ground

Absolute Maximum Ratings

Parameters	Value	Unit
Drain Voltage (V _{DD})	35	V
RF Input Power	+37	dBm
Load Impedance for Continuous Operation Without Damage	5:1	VSWR
Control (Gate) Voltage, V _{DD} = 0 VDC	15	V
Output Device Channel Temperature	+200	°C
Lead Temperature During Solder Reflow	+210	°C
Operating Temperature Range	-20 to +90	°C
Storage Temperature Range	-40 to +100	°C

Operation of this device beyond any one of these limits may cause permanent damage. For reliable continuous operation see typical setup values on the key specification table on the first page of the datasheet.

Note 1:

Internal RF decoupling is included on all bias leads. No additional bypass elements are required, however some applications may require energy storage on the drain leads to accommodate time-varying waveforms.

Note 2:

Gate voltage must be applied coincident with or after application of the drain voltage to prevent potentially destructive oscillations. Bias voltages should never be applied to a module unless it is terminated on both input and output.

Note 3:

The V_{GS} corresponding to a specific ID_Q will vary from module to module and may vary between the two sides of a dual RF module by as much as ±0.10 volts. This is due to the normal die-to-die variation in threshold voltage of

Note 4:

Since the gate bias of an LDMOS transistor changes with device temperature, it may be necessary to use a V_{GS} supply with thermal compensation if operation over a wide temperature range is required.



Caution: ESD Sensitive

Appropriate precaution in handling, packaging and testing devices must be observed.



Advance

SDM-08060 869-894 MHz 60W Amp

Quality Specifications

Parameter		Unit	Min	Typical	Max
ESD Rating	Human Body Model	V		8000	
MTTF	85°C Leadframe, 200°C Channel	H		1.2 X 10 ⁶	
R _{TH}	Thermal Resistance (Junction to Case)	°C/W		1.5	

Package Outline Drawing

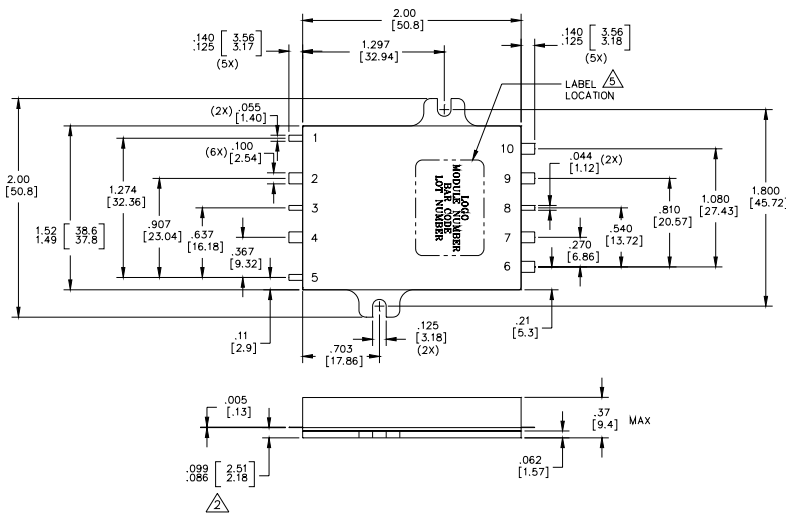

LEAD IDENTIFICATION	
Lead No.	Function
1	Bias 1
2	Ground
3	Input
4	Ground
5	Bias 2
6	V _{out}
7	Ground
8	Output
9	Ground
10	V _{out}
BASE PLATE	Ground

MODULE WEIGHT = 43gm NOMINAL

- NOTES: UNLESS OTHERWISE SPECIFIED
1. INTERPRET DRAWING PER ANSI Y14.5.
 2. MEASURE FROM THE BOTTOM OF THE LEADS.
 3. DIMENSIONS ARE INCHES[MM].
 4. LEAD IDENTIFICATION IS FOR REFERENCE ONLY.
 5. ORIENTATION OF LABEL IS TO BE AS SHOWN.

MPO-103060