

SC7461

INFRARED REMOTE CONTROL TRANSMITTER

DESCRIPTION

The SC7461 is a remote control transmitter utilizing CMOS Technology specially designed for infrared applications. It is capable of controlling 32 function keys and 3 double keys. SC7461 is housed in 24 pins, SO Package and provides 13 bits Custom Code.

FEATURES

- * CMOS Technology
- * Low Power Consumption
- * 32+3 Function Keys
- * Least External Components
- * Wide range of operating voltage: VDD=2.0~5.5V
- * Double key operation(No order of priority given)
- * On-Chip Oscillator can be constructed using an externally connected ceramic resonator
- * Up to 64 Custom Codes may be selected externally for SC7461

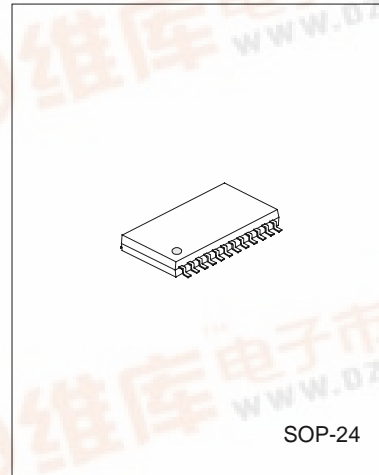

ORDERING INFORMATION

Part No.	Package
SC7461	SOP-24-375-1.27

APPLICATIONS

- * TV and VCR
- * Audio Equipment

- * Audio Cassette Deck
- * Air Conditioner
- * Multi-Media DVD Player

ORDERING INFORMATION

Valid Part Number	Package	Custom Code in Mask ROM
SC7461-100	SOP-24	C6~C12=1000000
SC7461-101	SOP-24	C6~C12=0000000
SC7461-103	SOP-24	C6~C12=0010000
SC7461-104	SOP-24	C6~C12=1010000



PIN CONFIGURATION

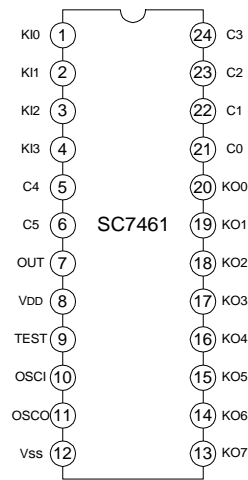

BLOCK DIAGRAM

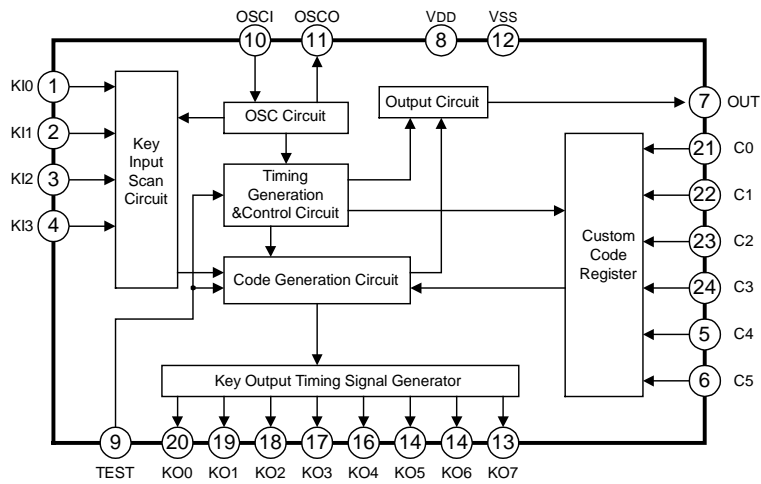

ABSOLUTE MAXIMUM RATING (Tamb=25°C, unless otherwise specified)

Characteristic	Symbol	Description	Value	Unit
Maximum Supply Voltage	VDD(max)	VDD	Vss-0.3~10	V
Input Voltage	VIN	Each Input pin	Vss-0.3~VDD+0.3	V
Output Voltage	VOUT	--	Vss-0.3~VDD+0.3	V
Output Current	IOUT	OUT	-35	mA
Allowable Power Dissipation	Pd(max)	Ta<=85°C	150	mW
Storage Temperature	Tstg	--	-40~+125	°C
Operating Temperature	Topr	--	-10~+70	°C

ELECTRICAL CHARACTERISTICS (Tamb=25°C, VDD=3.0V, unless otherwise specified)

Parameter	Symbol	Test conditions	Min	Typ	Max	Unit
Operating Supply Current	IDD	Key ON, Output: no load			1	mA
Quiescent Supply Current	IDS	All keys OFF, OSC stops			1	μA
High Level Output Current	IOH1	VDD=1.8V, VOH=1.0V		-8		mA
	IOH2	VDD=3.0V, VOH=2.0V		-25		mA
High Level Output Voltage	VOH	IOH=1mA	2.4			V
Low Level Output Voltage	VOL	IOL=1mA			0.2	V
Output OFF-State Leakage Current	IOFF	--			1	μA
Custom Code High Level Input Current	IIH	VIN= VDD			1	μA
Custom Code Low Level Input Current	IIL	VIN= VSS	-1			μA
Input Floating Voltage	VIF	--		0.1VDD		V
Input Pull-Down Resistance	RIN	--	75	100	125	kΩ

RECOMMENDED OPERATING CONDITIONS

(Tamb=25°C, fosc=455kHz, unless otherwise specified)

Characteristic	Symbol	Min.	Typ.	Max.	Unit
Supply Voltage	VDD	2.0	3.0	3.3	V
High Level Input Voltage	VIH	0.7VDD		VDD	V
Low Level Input Voltage	VIL	Vss		0.3VDD	V
Oscillation Frequency	fosc	400	455	500	KHz

PIN DESCRIPTION

Pin No.	Symbol	I/O	Description
1~4	KI0~KI3	I	Key Input Pins
7	OUT	O	Output Pins For Transit LED Drive
8	VDD	--	Power Supply
9	TEST	I	LSI Test Pin. This pin is normally set to High State or Floating.
10	OSCI	I	Oscillator Input Pin
11	OSCO	O	Oscillator Output Pin
12	VSS	--	Power Supply Vss=GND
13~20	KO7~KO0	O	Key Scan Timing Signal Output Pins
21~24	C0~C3	I	Custom Code Input Pins. Capable of externally setting 6 out of 13 bits for custom coding.
5,6	C4~C5		

FUNCTIONAL DESCRIPTION

1.OSCILLATION CIRCUIT

A self-biased type amplifier is housed by a CMOS Inverter Method. Thus, an oscillation circuit can be constructed by connecting a ceramic resonator. Please refer to Figure 4 for the oscillation circuit diagram.

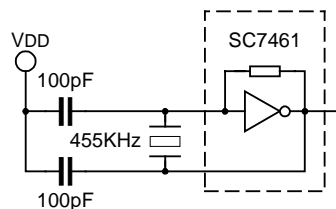

FIGURE 1. OSCILLATION CIRCUIT DIAGRAM

Unless the keys are being operated, the oscillation is normally stopped. Thus, power consumption is considerably reduced.

2.KEY INPUT

A total of 32 keys can be connected by Key Inputs--KI0~KI3 and Timing Signals--KO0~KO7. Double Key Operation is possible for only Key No.20 in combination with the other keys connected to the KO5 line, namely: Key No.21, 22 or 23. Thus, only the following key combinations may be used for the double key operation:

- 1).Key Nos.20 and 21
- 2).Key Nos.20 and 22
- 3).Key Nos.20 and 23

There is no order of priority given in key input. This means that keys designated for the double keying operation may be pressed in any sequence. When two keys (designated for the double key operation) are pressed simultaneously, a series of pulse is outputted according to each key input. Pressing other keys that are NOT intended for the double key operation do NOT generate any output.

The Key Matrix is given in the following diagram.

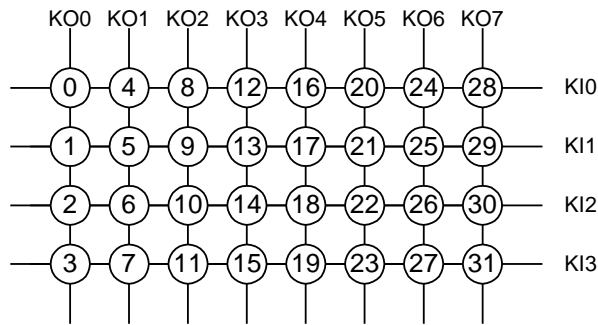

FIGURE 2. KEY MATRIX

3.DOUBLE KEY OPERATION

Double Key Operation is useful for tape deck recording operation. The following table shows the Key Data corresponding to the double keys pressed. Also refer to the Key Input Section.

Key	D0	D1	D2	D3	D4	D5	D6	D7
K20+K21	1	0	1	0	1	1	0	0
K20+K22	0	1	1	0	1	1	0	0
K20+K23	1	1	1	0	1	1	0	0

NOTE: Key Data--D6 and D7 may be preset to "0", "1" by mask option.

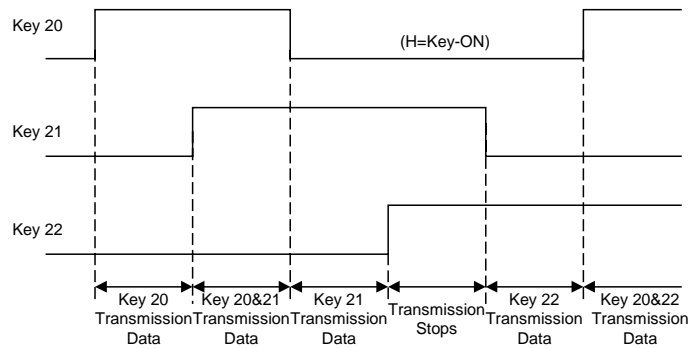

FIGURE 3. TRANSMISSION DATA DIAGRAM

When any of the double key combinations (Key No.20&21, Key No.20&22 and Key No.20&23) are pressed:

- 1).D5 is set to "1"
- 2).No Key Input Sequence is needed to perform the Double Key Operation

4.SC7461 DATA FRAME

A SC7461 Data Frame consists of 42 bits, namely: 13 bits Custom Code (C0~C12), 8 bits Key Data (D0~D7), and their respective Inverse Codes. Please refer to the figure below.

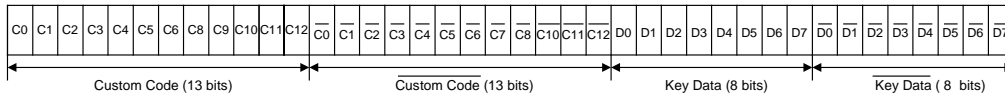

FIGURE 4. SC7461 DATA FRAME

CUSTOM CODE

The Custom Code consists of 13 bits, namely: C0~C12. 7 bits--C6~C12-- are fixed by the on-chip ROM while 6 bits--C0~C5--are pin-settable. SC7461 provides up to 64 custom codes that may be selected externally without any diode requirement. Please refer to the illustration below.

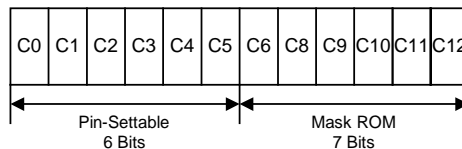

FIGURE 5. SC7461 CUSTOM CODE

For example: Given the following setting,

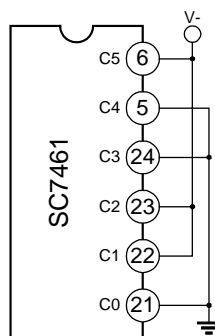

FIGURE 6. EXAMPLE CUSTOM CODE SETTING

then, the Custom Codes C0~C5 will have the following values:C0=0, C1=1, C2=1, C3=0, C4=0, C5=1.

KEY DATA

The Key Data has 8 bits (D0~D7) and has the following Key Data Codes. D6 and D7 may be preset to "0", "1".

Key	D0	D1	D2	D3	D4	D5	D6	D7
0	0	0	0	0	0	0	0	0
1	1	0	0	0	0	0	0	0
2	0	1	0	0	0	0	0	0
3	1	1	0	0	0	0	0	0
4	0	0	1	0	0	0	0	0
5	1	0	1	0	0	0	0	0
6	0	1	1	0	0	0	0	0
7	1	1	1	0	0	0	0	0
8	0	0	0	1	0	0	0	0
9	1	0	0	1	0	0	0	0
10	0	1	0	1	0	0	0	0
11	1	1	0	1	0	0	0	0
12	0	0	1	1	0	0	0	0
13	1	0	1	1	0	0	0	0
14	0	1	1	1	0	0	0	0
15	1	1	1	1	0	0	0	0
16	0	0	0	0	1	0	0	0
17	1	0	0	0	1	0	0	0
18	0	1	0	0	1	0	0	0
19	1	1	0	0	1	0	0	0
20	0	0	1	0	1	0	0	0
21	1	0	1	0	1	0	0	0
22	0	1	1	0	1	0	0	0
23	1	1	1	0	1	0	0	0
24	0	0	0	1	1	0	0	0
25	1	0	0	1	1	0	0	0
26	0	1	0	1	1	0	0	0
27	1	1	0	1	1	0	0	0
28	0	0	1	1	1	0	0	0
29	1	0	1	1	1	0	0	0
30	0	1	1	1	1	0	0	0
31	1	1	1	1	1	0	0	0

5.SC7461 TRANSMISSION CODE

The SC7461 transmission code consists of a leader code, 13 bits custom code, and 8 bits key data codes. The inverse code of both the custom and key data codes are also sent simultaneously; thus, allowing an extremely low error rate in the system configuration. Please refer to the following diagram.

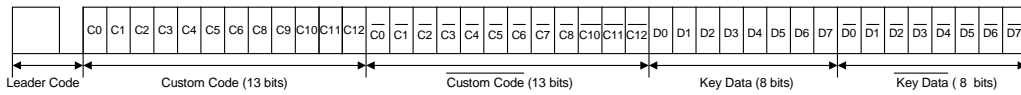

FIGURE 13. REM OUTPUT CODES

The leader code consists of a 9ms carrier waveform followed by a 4.5ms OFF waveform. It is used as the leader for the following codes (Custom, Data and their respective inverse codes). Thus, when the reception is configured by a microcomputer, the time relationship between the reception detection and other processes can be managed efficiently. The code uses the PPM (Pulse Position Modulation) Method, with "1" and "0" differentiated by the time between pulses.

6.SC7461 TRANSMISSION WAVEFORM

The SC7461 Transmission Waveform illustrated below were derived from the time period for $f_{osc}=455\text{KHz}$.

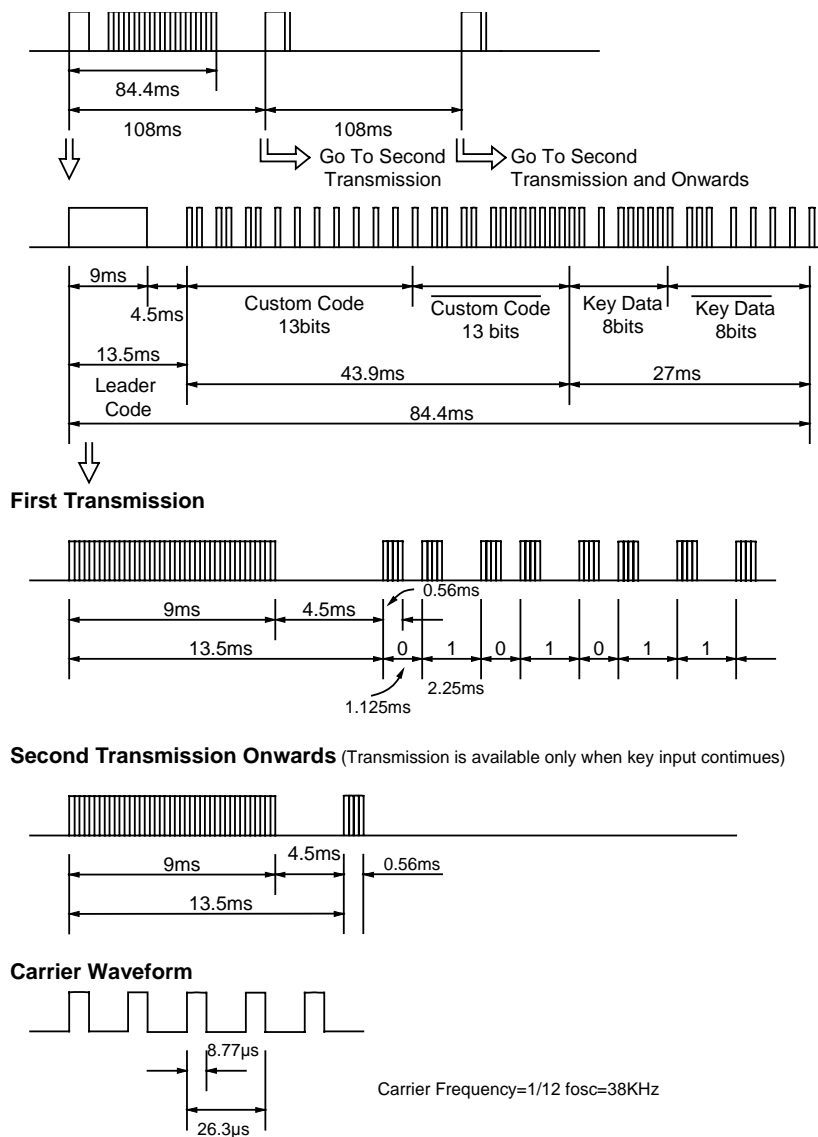
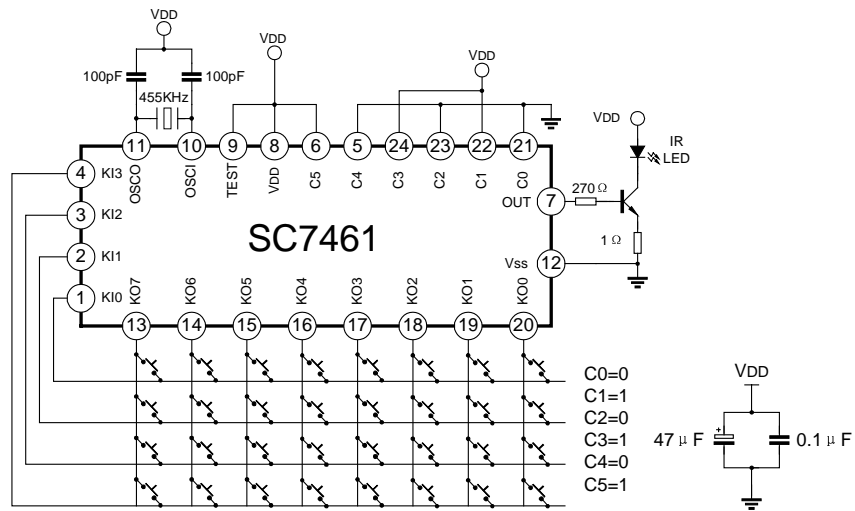

FIGURE 8. SC7461 TRANSMISSION WAVEFORM

TYPICAL APPLICATION CIRCUITS



Note:1. Two capacitance connect with VDD should as near as possible.
 2. The line between two capacitance and VDD and ground should as short as possible.

FIGURE 9. SC7461 APPLICATION CIRCUIT DIAGRAM

CHIP TOPOGRAPHY

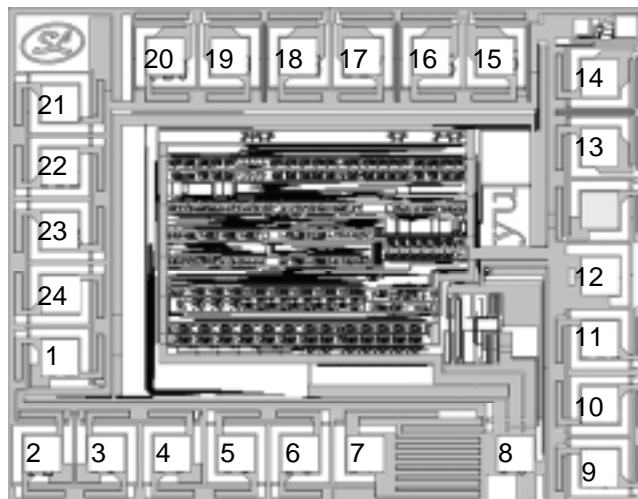

Size: 1.84 x 1.46 mm²

PAD COORDINATES (Unit: μm)

No.	Symbol	X	Y	No.	Symbol	X	Y
1	P1	-717.3	-273.5	13	P13	721.6	291.1
2	P2	-762.3	-532.3	14	P14	721.6	475.3
3	P3	-592.3	-532.3	15	P15	444.0	532.2
4	P4	-416.9	-532.3	16	P16	274.0	532.2
5	P5	-246.9	-532.3	17	P17	89.8	532.2
6	P6	-76.9	-532.3	18	P18	-80.2	532.2
7	P7	98.1	-532.3	19	P19	-264.4	532.2
8	P8	496.6	-532.3	20	P20	-434.4	532.2
9	P9	721.6	-569.3	21	P21	-717.3	407.0
10	P10	721.6	-399.3	22	P22	-717.3	237.0
11	P11	721.6	-223.9	23	P23	-717.3	67.0
12	P12	721.6	-53.9	24	P24	717.3	-103.0

Note: The original point of the coordinate is the die center.

PCB WIRE LAYOUT SCHEMATIC:

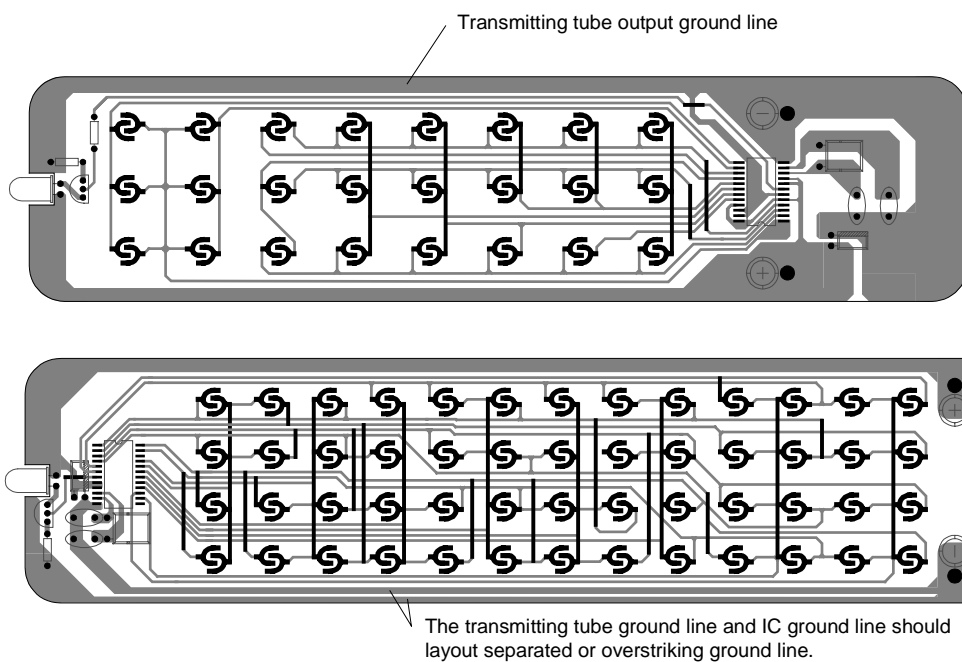

The above IC only use to hint, not to specified.

Note: :

- * In wire layout, the power filter capacitor should near to IC.
- * In wire layout, should avoid power line and ground line too long.
- * Recommended infrared transmit unit and IC ground line should layout separated, or overstriking lines.
- * The emitter of triode connect $1\ \Omega$ resistor at least.
- * Recommended triode use 9014.

PACKAGE OUTLINE

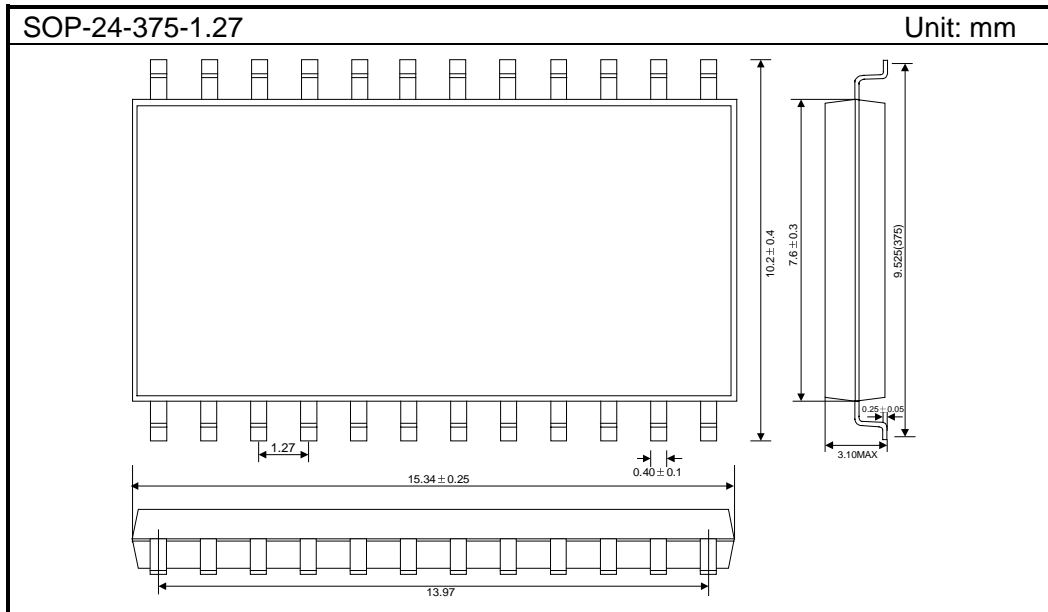

Attach**Revision History**

Data	REV	Description	Page
2000.12.31	2.0	Change name of company in page footer	
2001.12.12	2.1		
2002.02.28	2.2	Add the "Ordering information"	1
		Modify the "Features "	1
		Modify the "Absolute maximum rating" and "Recommended operating conditions"	3
		Modify the "Figure 6. example custom code setting"	6
		Modify "Typical application circuit"	10
		Add the "PCB wire layout schematic"	12
		Modify the "Package outline"	13