

PHOTODIODE

Si PIN photodiode S8385/S8729 series

SIP plastic package



S8385/S8729 series is a family of large area Si PIN photodiodes molded into a miniature plastic SIP package (75 % smaller in cubic volume than conventional types). Also available are lead forming types that save space when mounted on a PC board.

Features

- Small plastic package: 4 × 4.8 × 1.8[†] mm
- 2-pin SIP lead type (lead length: 4.9 mm)
- High sensitivity, high speed response
- 2 types of spectral response characteristics available
S8385, S8729, S8729-10: for visible to infrared range (λ=320 to 1100 nm)
S8385-04, S8729-04: for infrared (λ=760 to 1100 nm)
- Lead forming type also available (S8729-10)
- Active area
S8385 series: 2 × 2 mm
S8729 series: 2 × 3.3 mm

Applications

- Barcode scanners
- Spatial light transmission
- Optical switches
- Laser radar, etc.

General ratings / Absolute maximum ratings

Type No.	Dimensional outline	Package	Active area size (mm)	Effective active area (mm ²)	Absolute maximum ratings			
					Reverse voltage VR Max. (V)	Power dissipation P (mV)	Operating temperature Topr (°C)	Storage temperature Tstg (°C)
S8385	①	Plastic	2 × 2	4	20	50	-25 to +85	-40 to +100
S8385-04								
S8729			2 × 3.3	6.6				
S8729-04								
S8729-10								

Electrical and optical characteristics

Type No.	Spectral response range λ (nm)	Peak sensitivity wavelength λp (nm)	Photo sensitivity S (A/W)				Short circuit current Isc 100 lx (μA)	Dark current ID VR=5 V (nA)		Temperature coefficient of ID TCID (times/°C)	Cut-off frequency fc VR=5 V λ=780 nm RL=50 Ω -3 dB (MHz)	Terminal capacitance Ct VR=5 V f=1 MHz (pF)	NEP λ=λp (W/Hz ^{1/2})	
			λp	660 nm	780 nm	830 nm		Typ. (nA)	Max. (nA)					
S8385	320 to 1100	960	0.56	0.4	0.48	0.5	4.2	0.1	1.0	1.15	25	12	1.0 × 10 ⁻¹⁴	
S8385-04	760 to 1100			-	-	0.44	2.8							
S8729	320 to 1100			0.7	0.45	0.55	0.6	7.5	0.2					2.0
S8729-04	760 to 1100			0.68	-	-	0.52	5						
S8729-10	320 to 1100			0.7	0.45	0.55	0.6	7.5						



Si PIN photodiode S8385/S8729 series

Spectral response

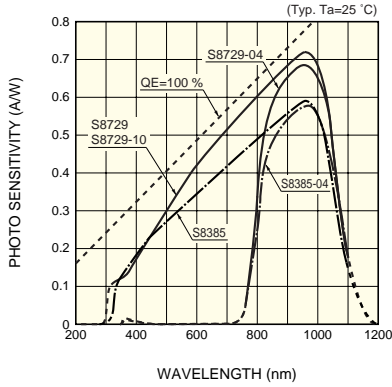

KPINB0271EB

Dark current vs. reverse voltage

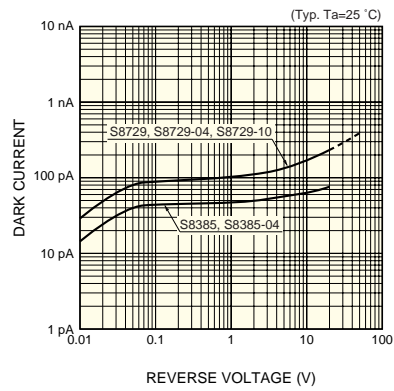

KPINB0273EA

Terminal capacitance vs. reverse voltage

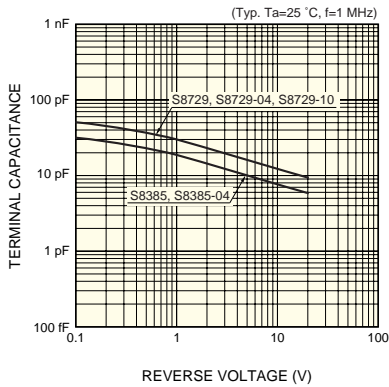

KPINB0272EA

Dimensional outlines (unit: mm)

S8385, S8385-04, S8729, S8729-04

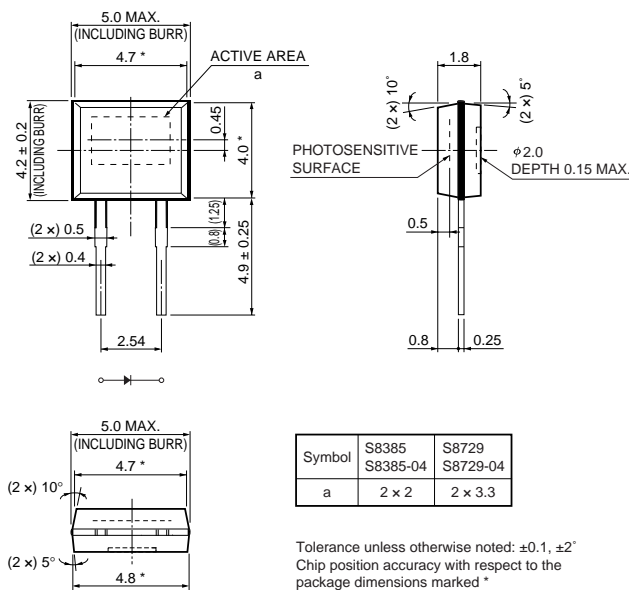

KPINA0090EA

S8729-10

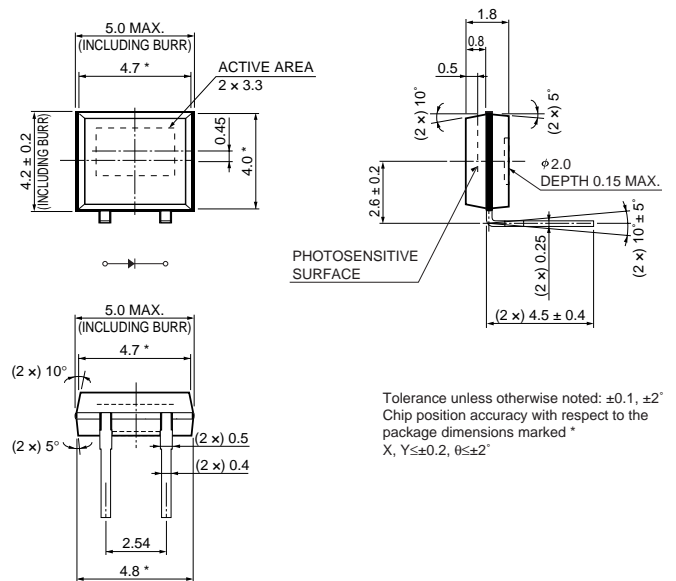

KPINA0091EB