

## Contents

General Description .....	1
Features .....	1
Applications .....	1
Pin Assignment .....	1
Marking .....	1
Logic Diagram .....	1
Physical Dimensions .....	2
Ordering .....	2
Absolute Maximum Ratings .....	2
Recommended Operating Conditions .....	3
DC Characteristics .....	3
AC Characteristics .....	4
Input Pin Equivalent Circuit .....	4
Frequently Asked Questions .....	5



## ■ General Description

The S-75V32ANC is a single 2-input OR gate fabricated by using advanced silicon-gate CMOS technology which provides the inherent benefit of CMOS low power consumption to achieve ultra high speed operation correspond to LSTTL IC's.

All gates of the internal circuitry have buffered outputs to ensure noise immunity and output stability.

Input voltage is allowed to be applied even if power voltage is not supplied because no diode is inserted between an input pin and  $V_{CC}$ .

This allows for interfaces between power supplies of different voltages and output level conversion from 5 V to 3 V and battery backup applications.

## ■ Features

- Wide power supply range: 2 V to 5.5 V
- Low current consumption: 1.0  $\mu$ A max. (at 5.5 V, 25°C)
- Typical propagation delay:  $t_{pd} = 3.8$  ns (at 5 V)
- High noise immunity:  $V_{NIH} = V_{NIL} = 28\% V_{CC}$  minimum
- Power down protection: All pins
- Very small plastic package: SC-88A

## ■ Applications

- Personal computers, peripherals
- Cellular phones
- Cameras
- Games

## ■ Pin Assignment

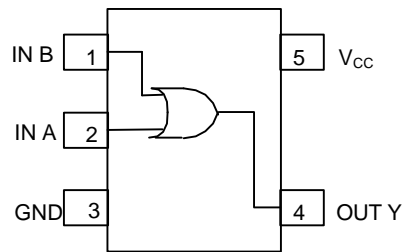

(Top view)

## ■ Marking

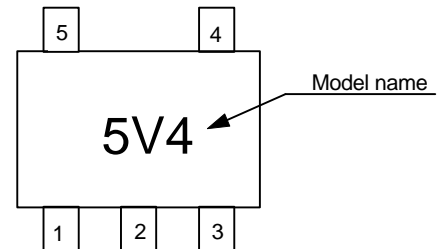

(Top view)

## ■ Logic Diagram

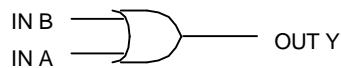

True Values

A	B	Y
L	L	L
L	H	H
H	L	H
H	H	H

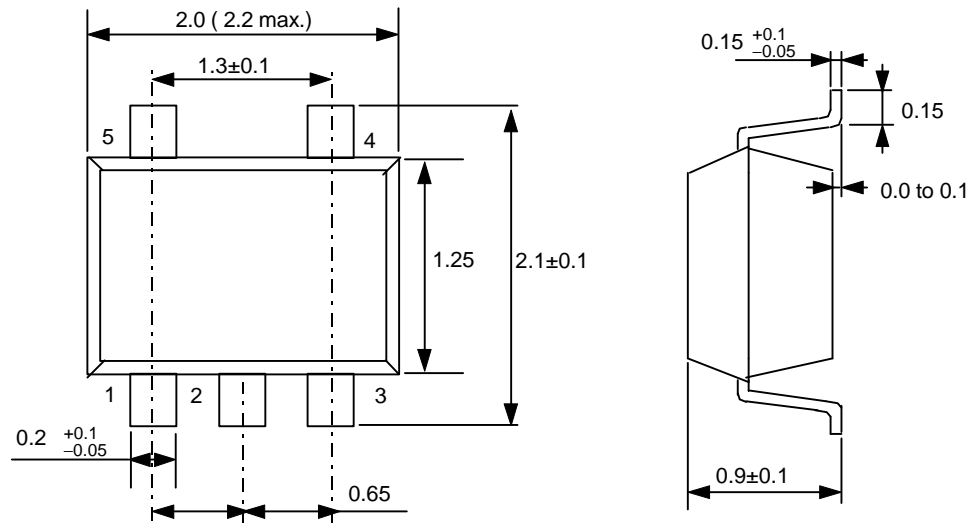

## ■ Ordering

Delivery form: Taping only

Model name: S-75V32ANC-5V4-T2

## ■ Absolute Maximum Ratings

$T_a = 25\text{ }^\circ\text{C}$

Item	Symbol	Conditions	Ratings	Unit
Power Supply Voltage	$V_{CC}$		-0.5 to +7.0	V
Input Voltage	$V_{IN}$		-0.5 to +7.0	V
Output Voltage	$V_{OUT}$		-0.5 to $V_{CC}+0.5$	V
Input Parasitic Diode Current	$I_{IK}$		-20	mA
Output Parasitic Diode Current	$I_{OK}$		$\pm 20$	mA
Output Current	$I_{OUT}$		$\pm 25$	mA
$V_{CC}/GND$ Current	$I_{CC}$		$\pm 50$	mA
Power Dissipation	$P_D$		200	mW
Storage Temp. Range	$T_{stg}$		-65 to +150	$^\circ\text{C}$
Lead Temperature (10 sec.)	TL		260	$^\circ\text{C}$

Parameter	Symbol	Standard	Unit
Power Voltage	$V_{CC}$	2 to 5.5	V
Input Voltage	$V_{IN}$	0 to 5.5	V
Output Voltage	$V_{OUT}$	0 to $V_{CC}$	V
Op. Temp. Range	Topr	-40 to +85	°C
Input Rise and Fall Time	dt/dv	0 to 100 ( $V_{CC}=3.3\pm 0.3V$ )	ns/V
		0 to 20 ( $V_{CC}=5\pm 0.5V$ )	

## ■ DC Characteristics

Parameter	Sym.	Conditions	Ta=25°C			Ta=-40 to 85°C					
			$V_{CC}$	MIN.	TYP.	MAX.	MIN.	MAX.			
Input Voltage	"H" level	$V_{IH}$	2.0	1.5	-	-	1.5	-			
			3 to 5.5	$V_{CC}\times 0.7$	-	-	$V_{CC}\times 0.7$	-			
	"L" level	$V_{IL}$	2.0	-	-	0.5	-	0.5			
			3 to 5.5	-	-	$V_{CC}\times 0.3$	-	$V_{CC}\times 0.3$			
Output Voltage	"H" level	$V_{OH}$	$V_{IN}=V_{IL}$ or $V_{IH}$	$I_{OH}=-50\mu A$	2.0	1.9	2.0	-	1.9	-	
					3.0	2.9	3.0	-	2.9	-	
					4.5	4.4	4.5	-	4.4	-	
					$I_{OH}=-4mA$	3.0	2.58	-	-	2.48	-
					$I_{OH}=-8mA$	4.5	3.94	-	-	3.80	-
	"L" level	$V_{OL}$	$V_{IN}=V_{IL}$	$I_{OH}=50\mu A$	2.0	-	0	0.1	-	0.1	
					3.0	-	0	0.1	-	0.1	
					4.5	-	0	0.1	-	0.1	
					$I_{OH}=4mA$	3.0	-	-	0.36	-	0.44
					$I_{OH}=8mA$	4.5	-	-	0.36	-	0.44
Input Current	$I_{IN}$	$V_{IN}=5.5V$ or GND	0 to 5.5	-	-	$\pm 0.1$	-	$\pm 1.0$			
Current Consump.	$I_{CC}$	$V_{IN}=V_{CC}$ or GND	5.5	-	-	1.0	-	10.0			

Input tr = tf = 3 ns (unless otherwise specified)

Parameter	Sym.	Measurement Conditions	Ta=25°C			Ta=-40 to 85°C		Unit		
			V <sub>CC</sub> (V)	C <sub>L</sub> (pF)	MIN.	TYP.	MAX.		MIN.	MAX.
Output Rise/Fall Time	t <sub>pLH</sub> t <sub>pHL</sub>		3.3±0.3	15	–	5.5	7.9	1.0	9.5	nS
				50	–	10.0	14.0	1.0	15.0	
			5.0±0.5	15	–	3.8	5.5	1.0	6.5	
				50	–	6.1	8.5	1.0	9.0	
Input Capacitance	C <sub>IN</sub>		–	4	10	–	10	pF		
Equiv. Int. Capacitance	C <sub>PD</sub>	Note <sup>1</sup>	–	15	–	–	–	pF		

Note<sup>1</sup> C<sub>PD</sub> is the no-load equivalent capacitance inside the circuitry. Refer to the measurement circuit shown below. Current consumption is averaged by the following equation.

$$I_{CC(opr)} = C_{PD} \cdot V_{CC} \cdot f_{in} + I_{CC}$$

#### Measurement Circuit

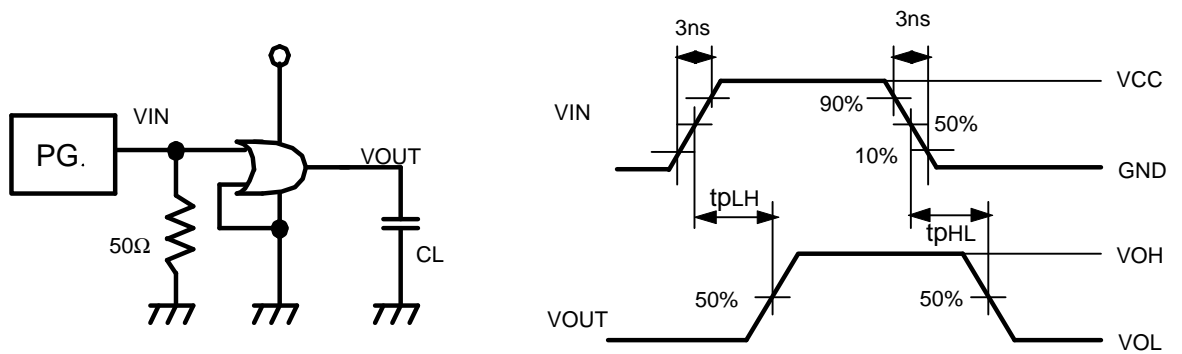

Remark: No-load output during measurement of current consumption.

#### ■ Input Pin Equivalent Circuit

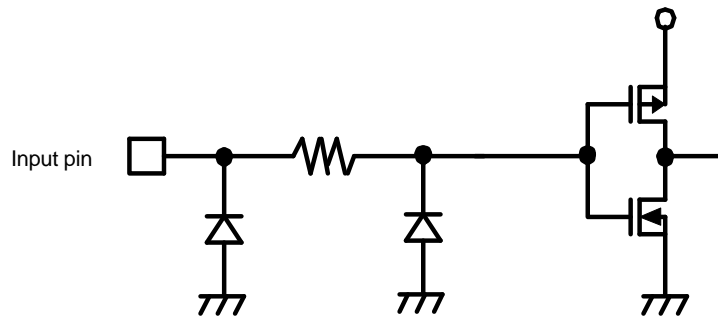

# Collection of Product FAQs

Author: Shirai Masaaki

Date: 99/01/12 (Tuesday) 12:49 (modified: 99/01/18(Monday))

## <Information level>

B: For Distri & Rep (Printing N.G.)

Index: A: General

## <Product>

Division name: 01 IC

Category 1: 17 ASSP

Category 2: 3. Mini Logic

Cal. No.: Overall

Related documents:

## Question:

What are the competitors' names, and what are the model numbers of the competing products? (cross-reference table)

## Answer:

See the cross-reference table below. The SII products are not compatible with those of other companies in all specifications.

In particular, the S-75V-series products have a longer delay time than that of the other companies' products due to their load capacity (see 75L, 75V).

### <How to use this table>

- When a customer refers to any product name in the SOT-23-5-equivalent column during a business-related conversation, introduce SII's SC88A products to this customer if new substrates are to be produced.
- For Toshiba and NS, each row includes two products. The lower product is almost equivalent to SII's (that is, operates at an equivalent speed). The upper product operates at a slower speed than SII's, so the corresponding SII products can be introduced as upgrade versions.

## Mini logic cross-reference

		SC88A equivalent			SOT-23-5 equivalent		
Company name	SII	Toshiba	NS(FAIRCHILD)	TJ	Toshiba	NS(FAIRCHILD)	TJ
Name	Mini-Logic	L-MOS	TinyLogic	SingleGate	L-MOS	TinyLogic	SingleGate
Product name	S-75V00ANC	TC7S00FU TC7SH00FU	NC7S00P5 NC7SZ00P5	SN74AHC1G00DCK	TC7S00F TC7SH00F	NC7S00M5 NC7SZ00M5	SN74AHC1G00DBV
	S-75V02ANC	TC7S02FU TC7SH02FU	NC7S02P5 NC7SZ02P5	SN74AHC1G02DCK	TC7S02F TC7SH02F	NC7S02M5 NC7SZ02M5	SN74AHC1G02DBV
	S-75V04ANC	TC7S04FU TC7SH04FU	NC7S04P5 NC7SZ04P5	SN74AHC1G04DCK	TC7S04F TC7SH04F	NC7S04M5 NC7SZ04M5	SN74AHC1G04DBV
	S-75VU04ANC	TC7SU04FU TC7SHU04FU	NC7SU04P5 NC7SZU04P5	SN74AHC1GU04DC	TC7SU04F TC7SHU04F	NC7SU04M5 NC7SZU04M5	SN74AHC1GU04DBV
	S-75V08ANC	TC7S08FU TC7SH08FU	NC7S08P5 NC7SZ08P5	SN74AHC1G08DCK	TC7S08F TC7SH08F	NC7S08M5 NC7SZ08M5	SN74AHC1G08DBV
	S-75V14ANC	TC7S14FU TC7SH14FU	NC7S14P5 NC7SZ14P5	SN74AHC1G14DCK	TC7S14F TC7SH14F	NC7S14M5 NC7SZ14M5	SN74AHC1G14DBV
	S-75V32ANC	TC7S32FU TC7SH32FU	NC7S32P5 NC7SZ32P5	SN74AHC1G32DCK	TC7S32F TC7SH32F	NC7S32M5 NC7SZ32M5	SN74AHC1G32DBV
	S-75V86ANC	TC7S86FU TC7SH86FU	NC7S86P5 NC7SZ86P5	SN74AHC1G86DCK	TC7S86F TC7SH86F	NC7S86M5 NC7SZ86M5	SN74AHC1G86DBV
	S-75L00ANC	TC7SL00FU	—	—	TC7SL00F	—	—
	S-75L02ANC	TC7SL02FU	—	—	TC7SL02F	—	—
	S-75L04ANC	TC7SL04FU	—	—	TC7SL04F	—	—
	S-75LU04ANC	TC7SLU04FU	—	—	TC7SLU04F	—	—
	S-75L08ANC	TC7SL08FU	—	—	TC7SL08F	—	—
	S-75L14ANC	—	—	—	—	—	—
	S-75L32ANC	TC7SL32FU	—	—	TC7SL32F	—	—
	S-75L86ANC	—	—	—	—	—	—

Speed image

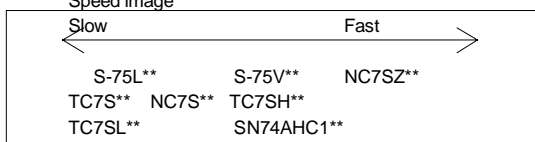

Note) Not all types are compared.  
For details, see individual specifications.

<Remarks>

FAQ No.: 17S75001