

ZH CONNECTOR

Disconnectable Crimp style connectors

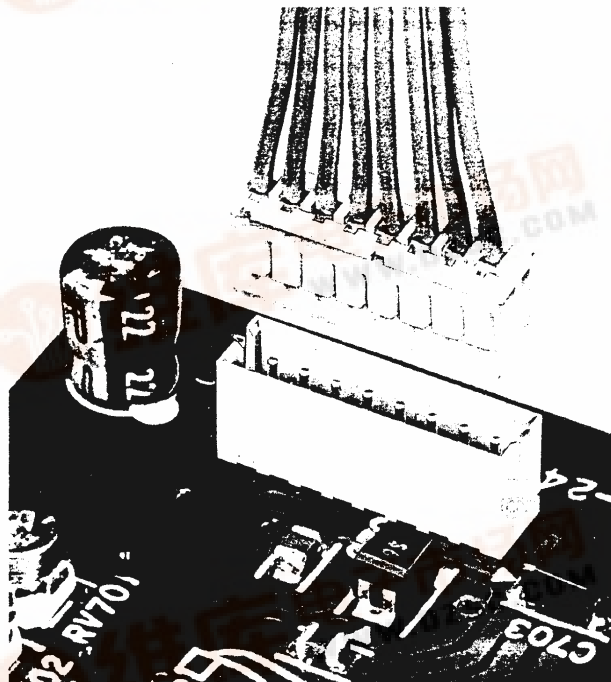

The ZH connector is very small with a mounting height of 5.6mm (.220") and a thickness of only 3.5mm (.138"). Contact retention lances on the housing make insertion easier, while the dimple at the center of the contact ensures reliable contact with the post.

Features

- **Compact, low profile design**

The ZH connector requires only about 45% of the installation space required by the standard JST 2.0mm (.079") pitch connector.

- **Housing lances**

The contact retention lances on the resilient housing allow visual confirmation of contact lock-in for easy and secure insertion.

- **Reliable contact construction**

The dimple at the center of the contact ensures positive contact and low contact resistance at all times, even when the connector is subjected to vibration or distortion. Therefore this connector is ideal for use under low current, low voltage conditions.

- **Distortion resistant construction**

The header is fully shrouded and thus protects the receptacle from damage that could be caused by mating the connectors at an angle or by otherwise mismatching the connectors.

- **Compatible with the ZR insulation displacement connectors**

The same shrouded header can be used for either the ZR IDC-style connector or the ZH crimp style connector. This allows both types of connector to be used interchangeably without replacing the header.

Specifications

- Current rating: 1.0A AC, DC (AWG #26)
- Voltage rating: 50V AC, DC
- Temperature range: -25°C to +85°C
(including temperature rise in applying electrical current)
- Contact resistance: Initial value/20m Ω max.
After environmental testing/30m Ω max.
- Insulation resistance: 500M Ω min.
- Withstanding voltage: 500V AC/minute
- Applicable wire: AWG #32 to #26
- Applicable PC board thickness: 0.6 to 1.2mm(.024" to .047")
- * Contact JST for details.

Standards

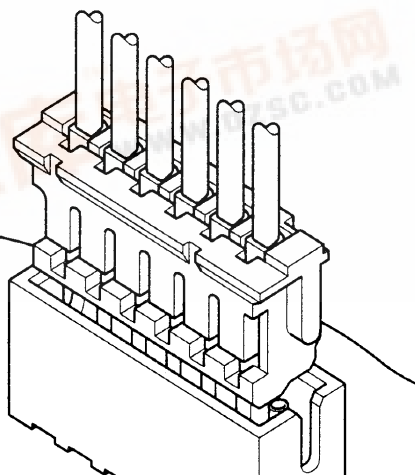

335-7545

ZH CONNECTOR

Contact

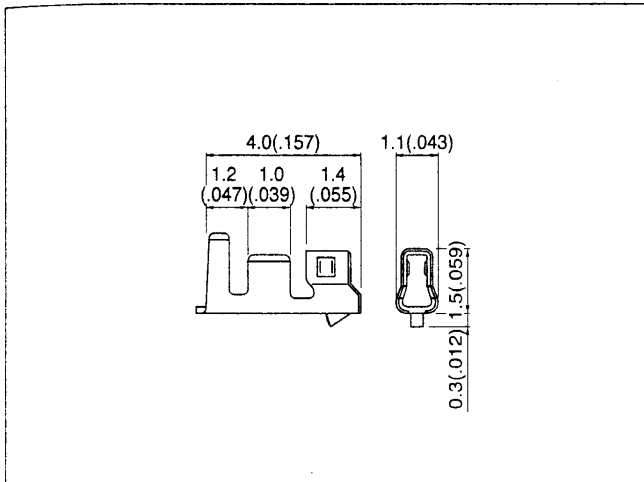

Model No.	Applicable wire			Q'ty / reel
	mm ²	AWG #	Insulation O.D.mm(in.)	
SZH-002T-P0.5	0.08 to 0.13	28 to 26	0.8 to 1.1(.031 to .043)	13,000
SZH-003T-P0.5	0.032 to 0.08	32 to 28	0.5 to 0.9(.020 to .035)	16,000

Material and Finish

Phosphor bronze, tin-plated

Housing

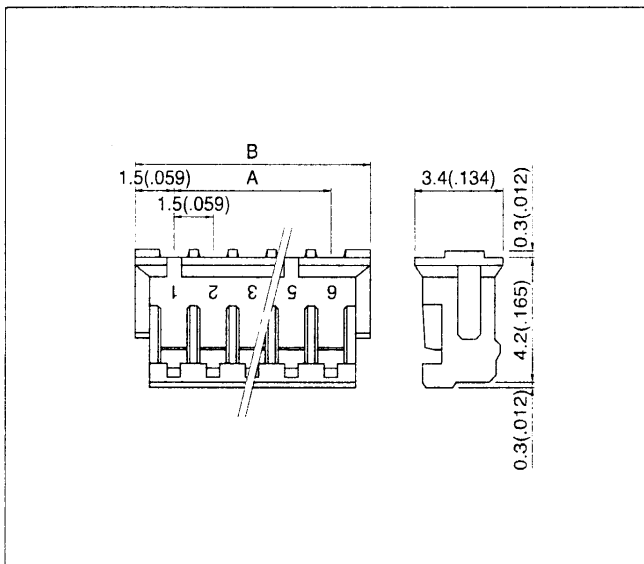

Circuits	Model No.	Dimensions mm(in.)		Q'ty / bag
		A	B	
2	ZHR- 2	1.5(.059)	4.5(.177)	1,000
3	ZHR- 3	3.0(.118)	6.0(.236)	1,000
4	ZHR- 4	4.5(.177)	7.5(.295)	1,000
5	ZHR- 5	6.0(.236)	9.0(.354)	1,000
6	ZHR- 6	7.5(.295)	10.5(.413)	1,000
7	ZHR- 7	9.0(.354)	12.0(.472)	1,000
8	ZHR- 8	10.5(.413)	13.5(.531)	1,000
9	ZHR- 9	12.0(.472)	15.0(.591)	1,000
10	ZHR-10	13.5(.531)	16.5(.650)	1,000
11	ZHR-11	15.0(.591)	18.0(.709)	1,000
12	ZHR-12	16.5(.650)	19.5(.768)	1,000
13	ZHR-13	18.0(.709)	21.0(.827)	1,000

Material

Nylon 66, UL94V-0, natural (white)

ZH CONNECTOR

Through-hole type shrouded header

The shrouded headers are interchangeable with those of the ZR insulation displacement connectors.

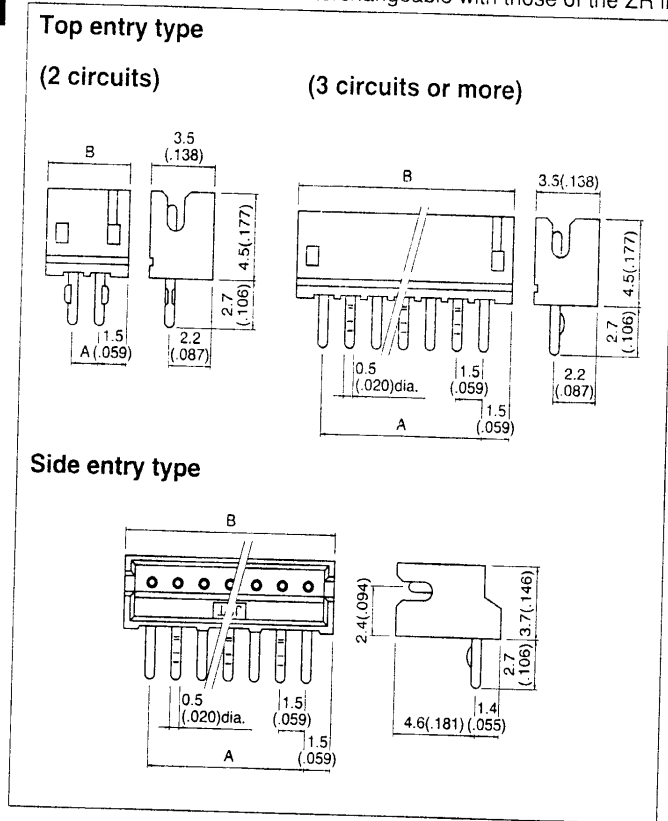

Circuits	Model No.		Dimensions mm(in.)		Qty / box	
	Top entry type	Side entry type	A	B	Top entry type	Side entry type
2	B 2B-ZR	S 2B-ZR	1.5(.059)	4.5(.177)	2,000	2,000
3	B 3B-ZR	S 3B-ZR	3.0(.118)	6.0(.236)	2,000	2,000
4	B 4B-ZR	S 4B-ZR	4.5(.177)	7.5(.295)	2,000	2,000
5	B 5B-ZR	S 5B-ZR	6.0(.236)	9.0(.354)	2,000	1,000
6	B 6B-ZR	S 6B-ZR	7.5(.295)	10.5(.413)	2,000	1,000
7	B 7B-ZR	S 7B-ZR	9.0(.354)	12.0(.472)	1,000	1,000
8	B 8B-ZR	S 8B-ZR	10.5(.413)	13.5(.531)	1,000	1,000
9	B 9B-ZR	S 9B-ZR	12.0(.472)	15.0(.591)	1,000	1,000
10	B10B-ZR	S10B-ZR	13.5(.531)	16.5(.650)	1,000	1,000
11	B11B-ZR	S11B-ZR	15.0(.591)	18.0(.709)	1,000	500
12	B12B-ZR	S12B-ZR	16.5(.650)	19.5(.768)	1,000	500
13	B13B-ZR	S13B-ZR	18.0(.709)	21.0(.827)	500	500

Material and Finish

Pin: Brass, copper-undercoated, tin/lead-plated
 Wafer: Glass-filled nylon 66, UL94V-0, natural (light gray)

Through-hole type PC board layout (viewed from soldering side) and Assembly layout

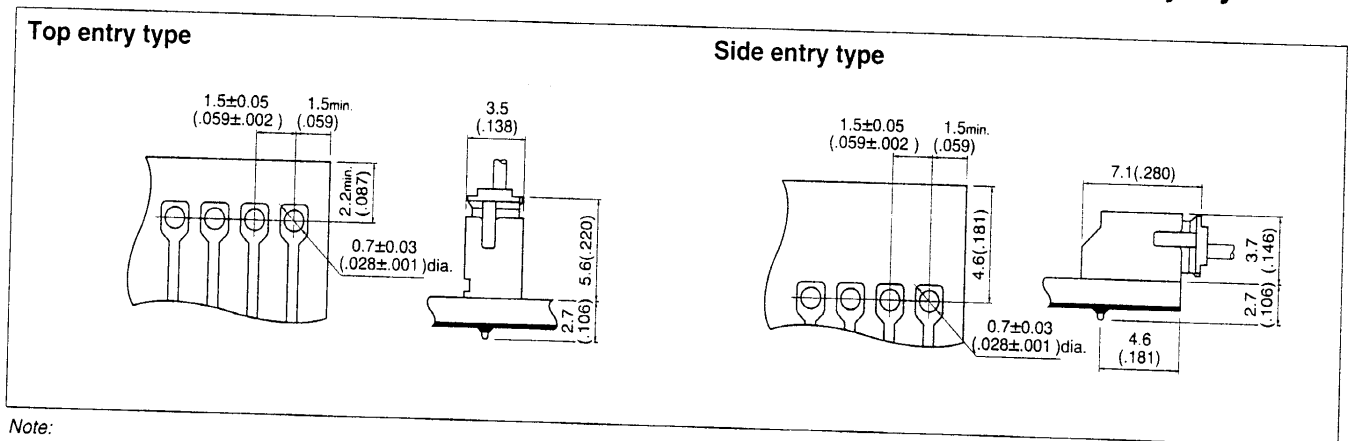

Note:

1. Tolerances are non-cumulative: $\pm 0.05\text{mm} (\pm .002")$ for all centers.
2. Hole dimensions differ according to the kind of PC board and piercing method. The dimensions above should serve as a guideline. Contact JST for details.

ZH CONNECTOR

SMT type shrouded header

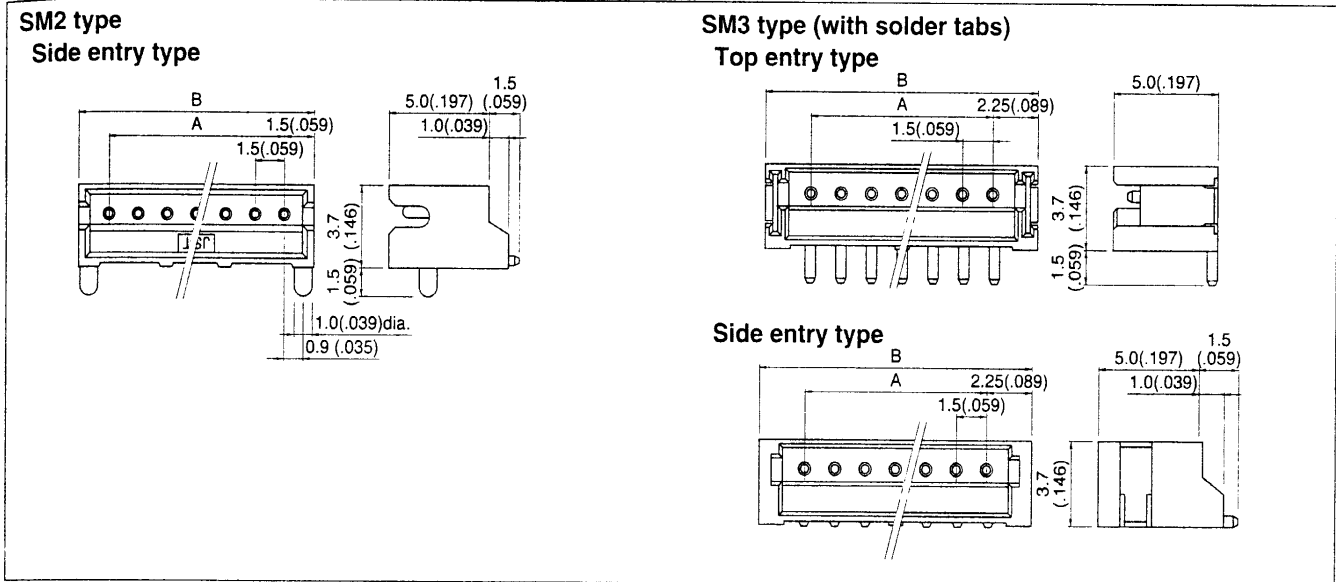

Circuits	SM2 type				SM3 type					
	Model No.	Dimensions mm(in.)		Q'ty / reel	Model No.		Dimensions mm(in.)		Q'ty / reel	
	Side entry type	A	B		Top entry type	Side entry type	A	B	Top entry type	Side entry type
2	S 2B-ZR-SM2-TF	1.5(.059)	4.5(.177)	1,000	B 2B-ZR-SM3-TF	S 2B-ZR-SM3A-TF	1.5(.059)	6.0(.236)	1,000	1,000
3	S 3B-ZR-SM2-TF	3.0(.118)	6.0(.236)	1,000	B 3B-ZR-SM3-TF	S 3B-ZR-SM3A-TF	3.0(.118)	7.5(.295)	1,000	1,000
4	S 4B-ZR-SM2-TF	4.5(.177)	7.5(.295)	1,000	B 4B-ZR-SM3-TF	S 4B-ZR-SM3A-TF	4.5(.177)	9.0(.354)	1,000	1,000
5	S 5B-ZR-SM2-TF	6.0(.236)	9.0(.354)	1,000	B 5B-ZR-SM3-TF	S 5B-ZR-SM3A-TF	6.0(.236)	10.5(.413)	1,000	1,000
6	S 6B-ZR-SM2-TF	7.5(.295)	10.5(.413)	1,000	B 6B-ZR-SM3-TF	S 6B-ZR-SM3A-TF	7.5(.295)	12.0(.472)	1,000	1,000
7	S 7B-ZR-SM2-TF	9.0(.354)	12.0(.472)	1,000	B 7B-ZR-SM3-TF	S 7B-ZR-SM3A-TF	9.0(.354)	13.5(.531)	1,000	1,000
8	S 8B-ZR-SM2-TF	10.5(.413)	13.5(.531)	1,000	B 8B-ZR-SM3-TF	S 8B-ZR-SM3A-TF	10.5(.413)	15.0(.591)	1,000	1,000
9	S 9B-ZR-SM2-TF	12.0(.472)	15.0(.591)	1,000	B 9B-ZR-SM3-TF	S 9B-ZR-SM3A-TF	12.0(.472)	16.5(.650)	1,000	1,000
10	S10B-ZR-SM2-TF	13.5(.531)	16.5(.650)	1,000	B10B-ZR-SM3-TF	S10B-ZR-SM3A-TF	13.5(.531)	18.0(.709)	1,000	1,000
11	S11B-ZR-SM2-TF	15.0(.591)	18.0(.709)	1,000	B11B-ZR-SM3-TF	S11B-ZR-SM3A-TF	15.0(.591)	19.5(.768)	1,000	1,000
12	S12B-ZR-SM2-TF	16.5(.650)	19.5(.768)	1,000	B12B-ZR-SM3-TF	S12B-ZR-SM3A-TF	16.5(.650)	21.0(.827)	1,000	1,000
13	S13B-ZR-SM2-TF	18.0(.709)	21.0(.827)	1,000	-	-	-	-	-	-

Material and Finish

Pin: Brass, copper-undercoated, tin/lead-plated
Wafer: Glass-filled nylon 46, UL94V-0, natural (white)

Note: The products listed above are supplied on embossed-tape.

SMT type PC board layout (viewed from component side)

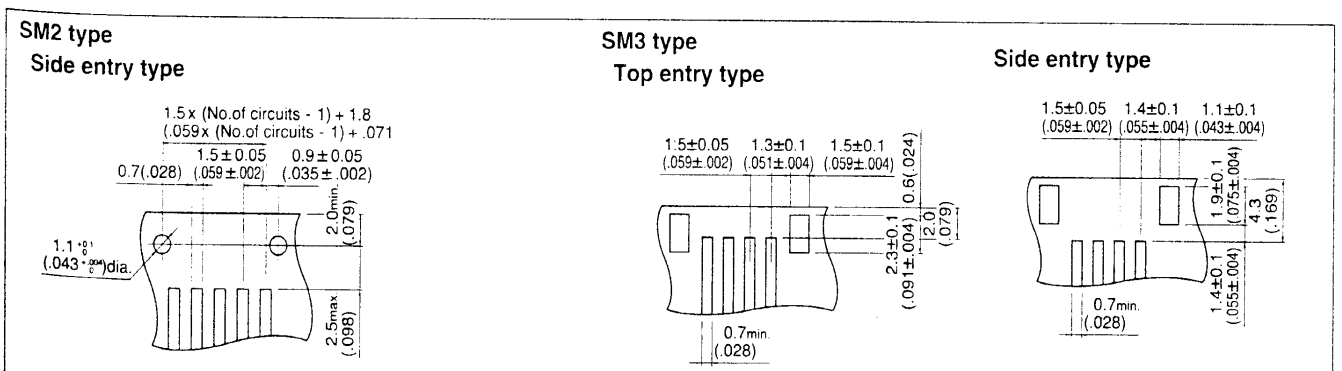

ZH CONNECTOR

Taping specifications

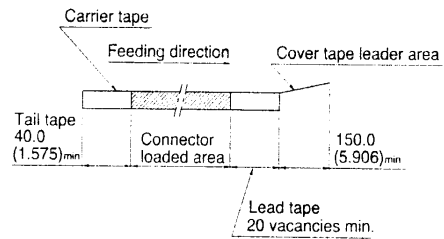
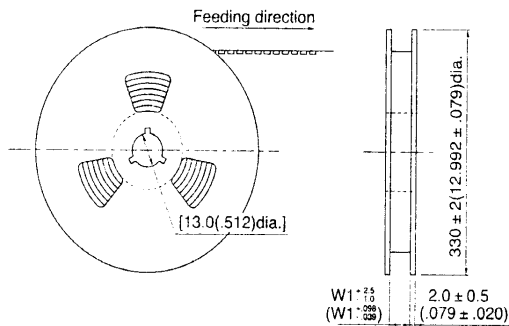

SM2 type
(Side entry type) 2 to 11 circuits
SM3 type
(Side entry type) 2 to 10 circuits

SM2 type
(Side entry type) 12 to 13 circuits
SM3 type
(Side entry type) 11 to 12 circuits

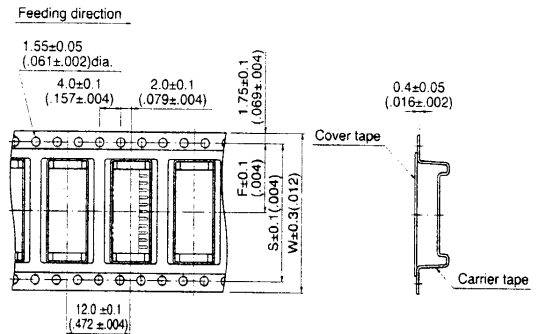
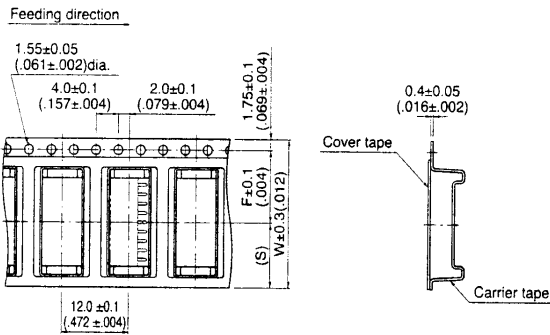

SM3 type
(Top entry type)
2 to 10 circuits

SM3 type
(Top entry type)
11 to 12 circuits

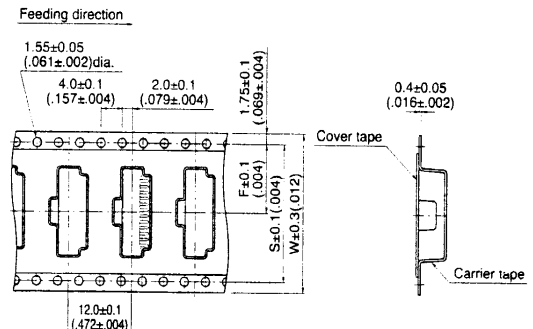
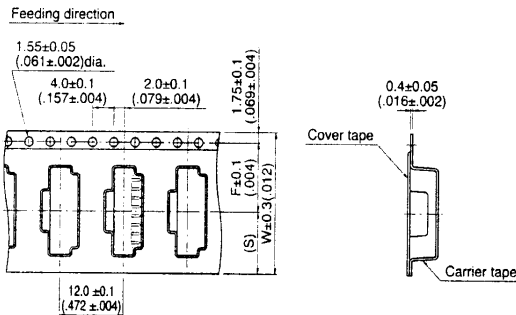

Circuits		Taping dimensions mm(in.)			Reel dimensions	Q'ty / reel	
		F	S	W	mm(in.)		
SM2 Type	Side entry type	2 to 6	7.5(.295)	6.75(.266)	16.0(.630)	17.5(.689)	1,000
		7 to 11	11.5(.453)	10.75(.423)	24.0(.945)	25.5(1.004)	1,000
		12 to 13	14.2(.559)	28.4(1.118)	32.0(1.260)	33.5(1.319)	1,000
SM3 Type	Top entry type	2	5.5(.217)	4.75(.187)	12.0(.472)	13.5(.531)	1,000
		4 to 5	7.5(.295)	6.75(.266)	16.0(.630)	17.5(.689)	1,000
		6 to 10	11.5(.453)	10.75(.423)	24.0(.945)	25.5(1.004)	1,000

Note:
Specifications conform to JIS C 0806. The tape width, connector recess dimensions, etc. are determined by the number of circuits and external shape of the connector to be loaded.