

FEATURES

- Complies with Bellcore and ITU-T specifications for jitter tolerance, jitter transfer and jitter generation
- On-chip high frequency PLL with internal loop filter for clock recovery
- Supports clock recovery for OC-12/STM-4 (S3026A) (622.08 Mbit/s) or OC-3/STM-1 (155.52 Mbit/s) (S3026A-1) NRZ data
- 19.44 MHz reference frequency
- Lock detect—monitors run length (S3026A only) and frequency
- 350 mW typical power dissipation
- Low-jitter PECL interface
- Maintains downstream clock in absence of data inputs
- Micro-power Bipolar technology
- 5V supply
- Available in a 20 TSSOP package

GENERAL DESCRIPTION

The function of the S3026 clock recovery unit is to derive high speed timing signals for SONET/SDH-based equipment. The S3026 is implemented using AMCC's proven Phase Locked Loop (PLL) technology.

The S3026 receives either an OC-12/STM-4 or OC-3/STM-1 scrambled NRZ signal and recovers the clock from the data. The chip outputs a differential PECL bit clock and retimed data. Figure 1 shows a typical network application.

The S3026 utilizes an on-chip PLL which consists of a phase detector, a loop filter, and a voltage controlled oscillator (VCO). The phase detector compares the phase relationship between the VCO output and the serial data input. A loop filter converts

Figure 1. System Block Diagram

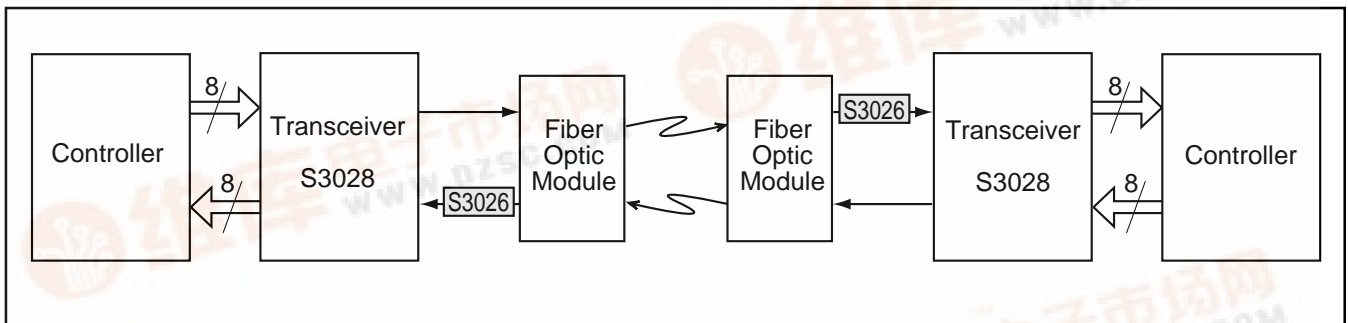
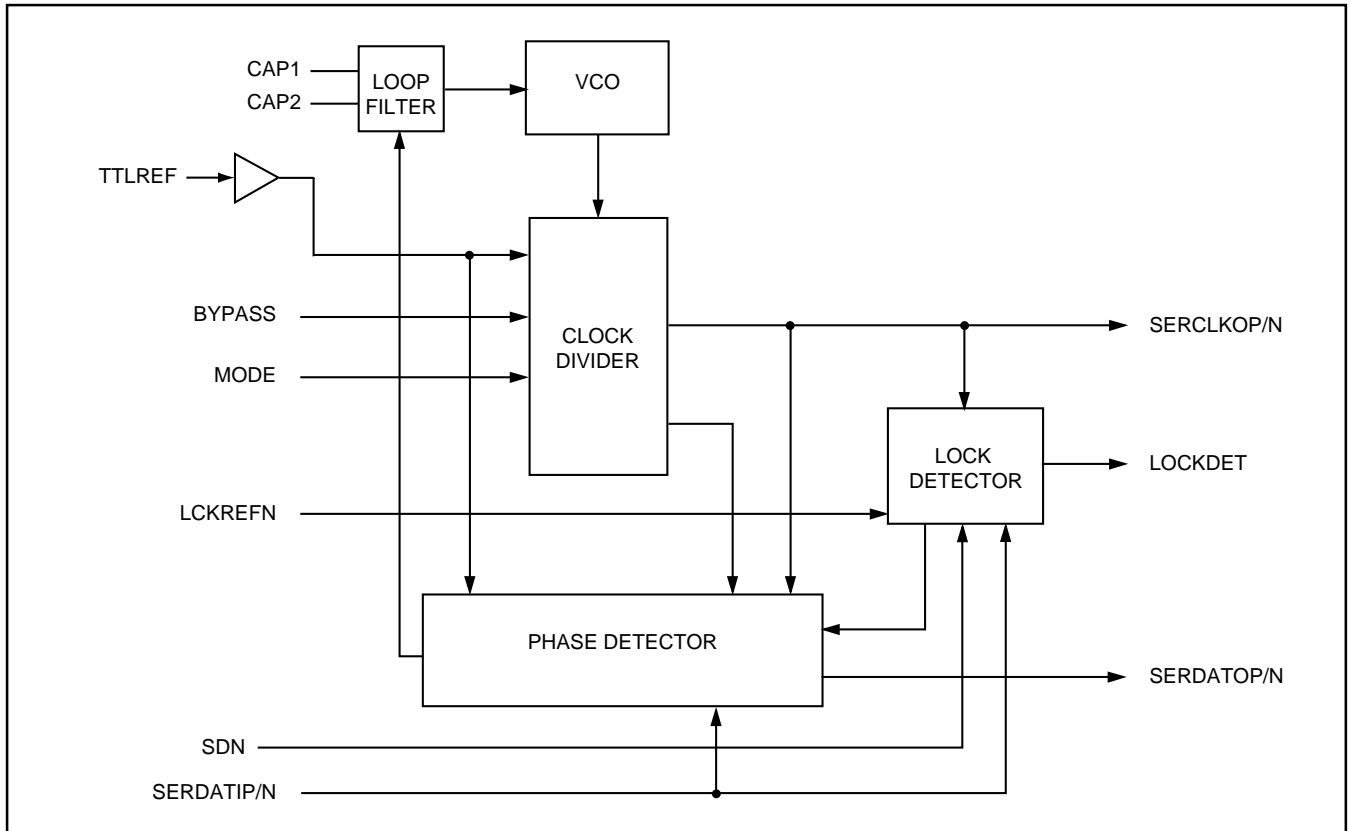

Figure 2. Functional Block Diagram



the phase detector output into a smooth DC voltage, and the DC voltage is input to the VCO whose frequency is varied by this voltage. A block diagram is shown in Figure 2.

OVERVIEW

The S3026 supports clock recovery for the OC-12/STM-4 or OC-3/STM-1 data rates. Differential serial data is input to the chip at the specified rate and clock recovery is performed on the incoming data stream. An external 19.44 MHz crystal oscillator is required to minimize the PLL lock time and provide a stable output clock source in the absence of serial input data. Retimed data and clock are output from the S3026.

CHARACTERISTICS

Performance

The S3026 PLL complies with the jitter specifications proposed for SONET/SDH equipment defined by the T1X1.6/91-022 document, when used with differential inputs and outputs as shown in Figure 3.

Jitter Transfer

The jitter transfer function is defined as the ratio of jitter on the output OC-N/STS-N signal to the jitter applied on the input OC-N/STS-N signal versus frequency. Jitter transfer requirements are shown in Figure 5. The measurement condition is that input sinusoidal jitter up to the mask level in Figure 4 be applied for each of the OC-N/STS-N rates.

Input Jitter Tolerance

Input jitter tolerance is defined as the peak to peak amplitude of sinusoidal jitter applied on the input signal that causes an equivalent 1 dB optical/electrical power penalty. SONET input jitter tolerance requirements are shown in Figure 4. The measurement condition is the input jitter amplitude which causes an equivalent of 1 dB power penalty.

Serial Data Output Set-up and Hold Time

The output set-up and hold times are represented by the waveforms shown in Figure 3.

Jitter Generation

The jitter of the serial clock and serial data outputs shall not exceed 0.01 UI when a serial data input with less than 14 ps (OC-12) or 56 ps (OC-3) rms jitter is presented to the serial data inputs.

Figure 3. Clock Output to Data Transition Delay

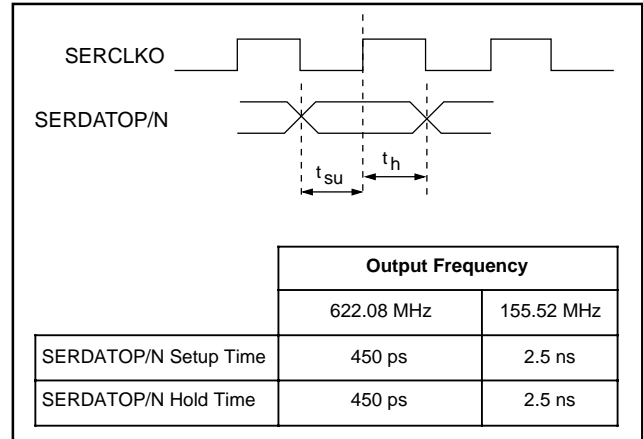

Figure 4. Input Jitter Tolerance Specification

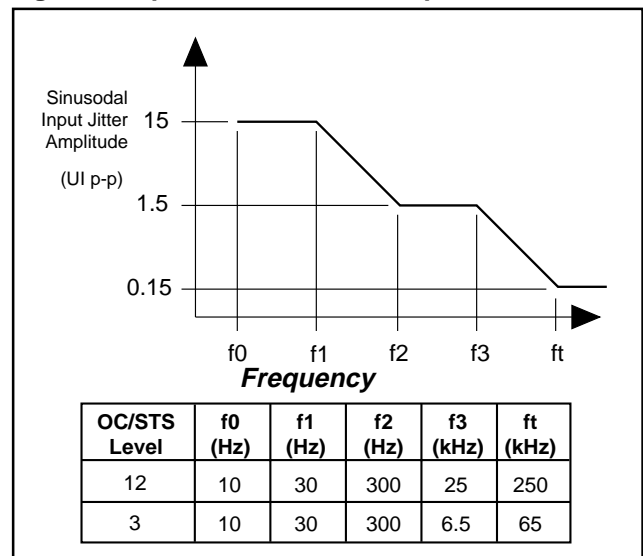
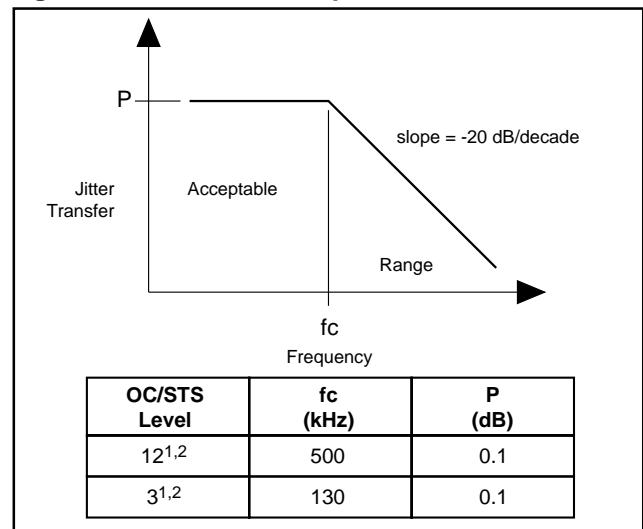

Figure 5. Jitter Transfer Specification



1. Bellcore Specifications: TR-NWT-000253, Issue 2, December 1991.

2. CCITT Recommendations: G.958.

Table 1. S3026 Pin Assignment and Descriptions

Pin Name	Level	I/O	Pin #	Description
SERDATIP SERDATIN	Diff. PECL	I	2 3	Serial Data In. A clock is recovered from transitions on these inputs.
BYPASS	TTL	I	16	Bypass Enable. Active High. Used during production test to bypass the VCO in the PLL. Tie to ground for normal operation.
SDN	PECL	I	15	Signal Detect. Active Low. A single-ended 10K PECL input to be driven by the external optical receiver module to indicate a loss of received optical power. When SDN is inactive, the PLL will be forced to lock to the TTLREF input and the SERDATOP/N output will be held in the logic low state. When Signal Detect (SDN) is active, data on the SERDATIP/N pins will be processed normally.
TTLREF	TTL	I	7	Reference clock input used to establish the initial operating frequency of the clock recovery PLL and also used as a standby clock in the absence of data or when LOCKDET is inactive.
CAP1 CAP2	–	I	18 17	The loop filter capacitor and resistors are connected to these pins. The capacitor value should be 1.0 μ F \pm 10% tolerance, X7R dielectric. 16–50 V is recommended. The resistor values are 68 Ω \pm 5%. See Figure 7.
LCKREFN	TTL	I	8	Lock to Reference. Active Low. When active, the serial clock output will be forced to lock to the TTLREF local reference input and the SERDATOP/N output will be held in the logic low state. See Table 3.
MODE	TTL	I	6	Rate select used to select the bit rate of the device. Set High to select 622.08 Mbit/s. Set Low to select 155.52 Mbit/s.
SERDATOP SERDATON	Diff. PECL	O	14 13	Serial Data Out signal that is the delayed version of the incoming data stream (SERDATI) updated on the falling edge of Serial Clock Out (SERCLKOP).
SERCLKOP SERCLKON	Diff. PECL	O	12 11	Serial Clock Out signal that is phase aligned with Serial Data Out (SERDATOP/N). (See Figure 3.)

Table 1. S3026 Pin Assignment and Descriptions (Continued)

Pin Name	Level	I/O	Pin #	Description
LOCKDET	PECL	O	5	<p>Lock Detect. Active High. When active, this output indicates that the PLL is locked to the serial data inputs and valid clock and data are present at the serial outputs. When inactive, it indicates that the PLL is locked to the local reference clock. The lock detect will go inactive under the following conditions:</p> <ol style="list-style-type: none"> 1. If SDN is inactive. 2. If the VCO drifts away from the local reference clock by more than 1000 ppm. 3. If LCKREFN is active. 4. If the serial data inputs contain insufficient run length (100 to 800 bit times). This only applies to the S3026A for OC-12 applications. <p>Lock detect will return to the active state if the serial clock is within 250 ppm of the reference clock frequency.</p>
DGND	GND	–	9	Digital Ground (0V)
DVCC	+5V	–	10	Digital Power Supply (+5V)
AGND	GND	–	4, 19	Analog Ground (0V)
AVCC	+5V	–	1, 20	Analog Power Supply (+5V)

Figure 6. S3026A TSSOP Package

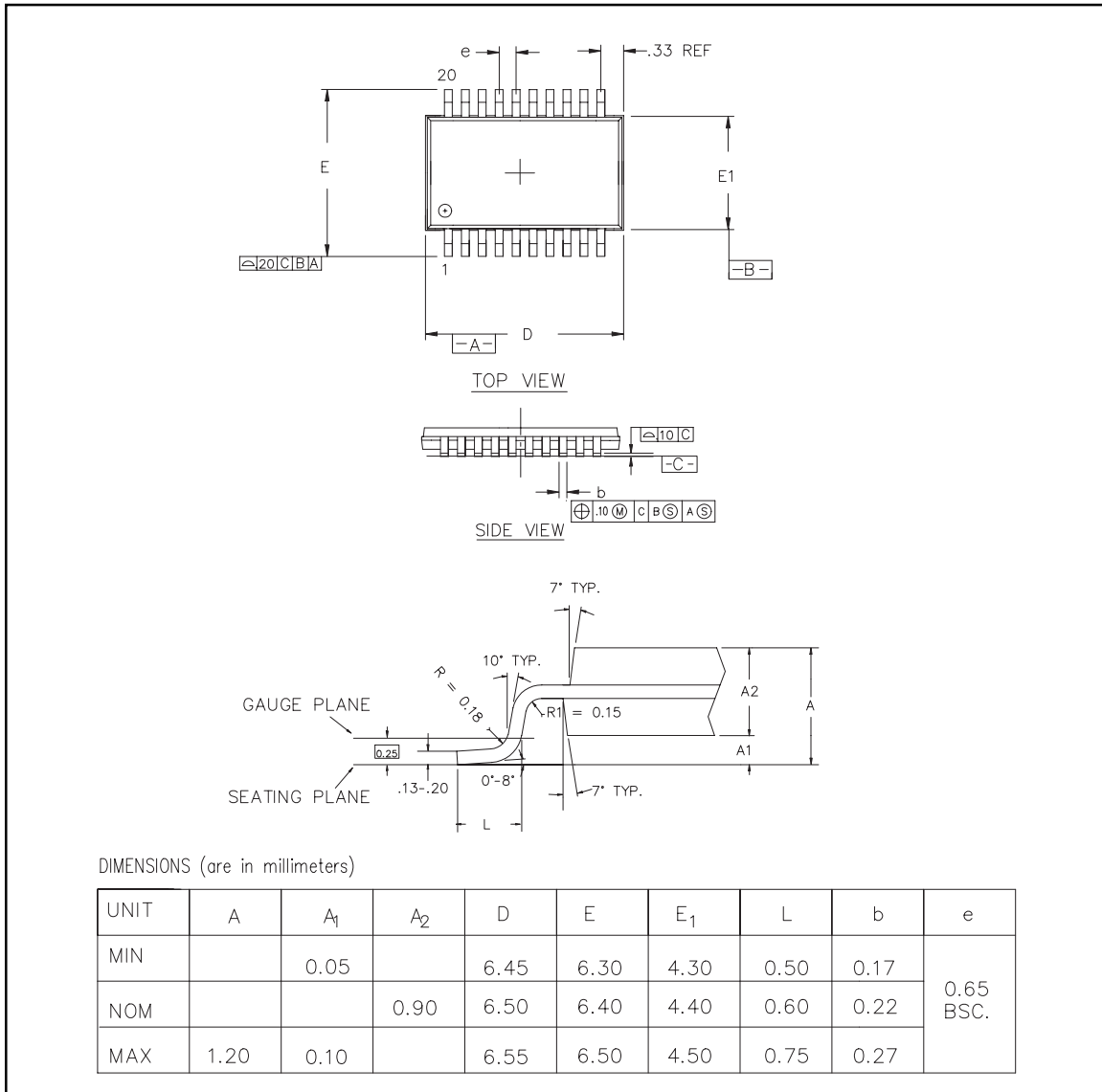

Table 2. Thermal Management

Max Power	θ_{ja}	θ_{jc}
0.58 W	77° C/W	25° C/W

Table 3. Clock and Data Output Control

SDN	LCKREFN	LOCK DETECT	SERCLKOP/N	SERDATP/N
X	X	0	Active	0
X	0	0	Active	0
1	X	0	Active	0
0	1	1	Active	Active

Table 4. Absolute Maximum Ratings

Parameter	Min	Typ	Max	Units
Storage Temperature	-65		+150	° C
Voltage on V_{CC} with respect to GND	-0.5		+7.0	V
Voltage on any TTL Input Pin	-0.5		+5.5	V
Voltage on any PECL Input Pin	V_{CC} -2.0		V_{CC}	V
TTL Output Sink Current			20	mA
TTL Output Source Current			10	mA
High Speed PECL Output Source Current			50	mA
ESD Sensitivity ¹	Under 500			V

1. Human body model.

Table 5. Recommended Operating Conditions

Parameter	Min	Typ	Max	Units
Ambient Temperature Under Bias (Industrial)	-40		+85	° C
Ambient Temperature Under Bias (Commercial)	0		+70	° C
Voltage on V_{CC} with respect to GND	4.75	5.0	5.25	V
Voltage on any TTL Input Pin	0.0		V_{CC}	V
Voltage on any PECL Input Pin	V_{CC} -2		V_{CC}	V
PECL Output Source Current (50Ω to V_{CC} -2V)		14	25	mA
ICC Supply Current		80	110	mA

Table 6. Performance Specifications

Parameter	Min	Typ	Max	Units	Condition
Nominal VCO Center Frequency		622.08		MHz	
Reference Clock Frequency Tolerance Clock Recovery ¹	-250		+250	ppm	
OC-12/STS-12 Capture Range		±500		ppm	With respect to fixed reference frequency
Clock Output Duty Cycle	45		55	% of UI	Minimum transition density of 20%
Acquisition Lock Time ¹ OC-12/STS-12			16	µsec	With device already powered up and valid REFCLK.
PECL Output Rise & Fall Times			600	ps	10% to 90%, 50Ω to -2V equivalent load, 5 pF cap
SERCLKOP/N Jitter Generation		0.005	0.01	UI	With less than 14 ps rms jitter on SERDATIP/N data inputs
OC-12/STS-12 Jitter Tolerance ¹	0.5			UI	Sinusoidal input jitter. Amplitude on SERDATIP/N data inputs from 250 kHz to 5 MHz.

1. Guaranteed but not tested.

Table 7. TTL Input/Output DC Characteristics¹
 $(T_A = -40^\circ\text{C to } +85^\circ\text{C}, V_{CC} = 5\text{ V } \pm 5\%)$

Symbol	Parameters	Min	Typ	Max	Units	Test Conditions
V_{IL}^1	Input Low Voltage			0.8	V	Guaranteed input Low voltage for all inputs
V_{IH}^1	Input High Voltage	2.0			V	Guaranteed input High voltage for all inputs
I_{IL}	Input Low Current	-400.0			μA	$V_{CC} = \text{MAX}, V_{IN} = 0.5\text{V}$
I_{IH}	Input High Current			50.0	μA	$V_{CC} = \text{MAX}, V_{IN} = 2.7\text{V}$
I_I	Input High Current at Max V_{CC}			1.0	mA	$V_{CC} = \text{MAX}, V_{IN} = 5.25\text{V}$
I_{OS}	Output Short Circuit Current	-100.0		-25.0	mA	$V_{CC} = \text{MAX}, V_{OUT} = 0.5\text{V}$
V_{IK}	Input Clamp Diode Voltage	-1.2			V	$V_{CC} = \text{MIN}, I_{IN} = 18.0\text{mA}$
V_{OL}	TTL Output Low Voltage			0.5	V	$V_{CC} = \text{MIN}, I_{OL} = 8\text{mA}$
V_{OH}	TTL Output High Voltage	2.4			V	$V_{CC} = \text{MIN}, I_{OH} = -1.0\text{mA}$

1. These input levels provide a zero-noise immunity and should only be tested in a static, noise-free environment.

Table 8. PECL Input/Output DC Characteristics
 $(T_A = -40^\circ\text{C to } +85^\circ\text{C}, V_{CC} = 5\text{ V } \pm 5\%)$

Symbol	Parameters	Min	Typ	Max	Units	Conditions
V_{IL}	Input Low Voltage	V_{CC} -2.000		V_{CC} -1.441	V	Guaranteed input Low voltage for single-ended inputs
V_{IH}	Input High Voltage	V_{CC} -1.225		V_{CC} -0.570	V	Guaranteed input High voltage for single-ended inputs
V_{IL}	Input Low Voltage	V_{CC} -2.000		V_{CC} -0.700	V	Guaranteed input Low voltage for differential inputs
V_{IH}	Input High Voltage	V_{CC} -1.750		V_{CC} -0.450	V	Guaranteed input High voltage for differential inputs
V_{ID}	Input Differential Voltage	0.250	0.500	1.400	V	Differential input voltage
I_{IH}	Input High Current	-0.500		20.000	μA	$V_{ID} = 500\text{mV}$
I_{IL}	Input Low Current	-0.500		20.000	μA	$V_{ID} = 500\text{mV}$
V_{OL}	Output Low Voltage	V_{CC} -2.000		V_{CC} -1.500	V	50 Ω termination to $V_{CC} - 2\text{V}$
V_{OH}	Output High Voltage	V_{CC} -1.110		V_{CC} -0.670	V	50 Ω termination to $V_{CC} - 2\text{V}$
V_{OD}	Output Differential Voltage	0.390		1.330	V	Differential output voltage

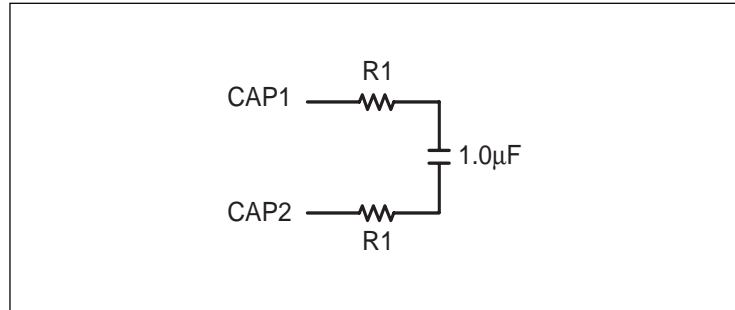
Figure 7. External Loop Filter

R1 = 68Ω for 622.08 Mbps

R1 = 84Ω for 155.52 Mbps

Ordering Information

PREFIX	DEVICE	PACKAGE	SPEED GRADE
S – Integrated Circuit	3026	A – 20 TSSOP	1– 155 Mbps Blank – 622 Mbps

X
Prefix

XXXX
Device

X
Package

X
Speed Grade



Applied Micro Circuits Corporation • 6290 Sequence Dr., San Diego, CA 92121

Phone: (858) 450-9333 • (800)755-2622 • Fax: (858) 450-9885

<http://www.amcc.com>

AMCC reserves the right to make changes to its products or to discontinue any semiconductor product or service without notice, and advises its customers to obtain the latest version of relevant information to verify, before placing orders, that the information being relied on is current.

AMCC does not assume any liability arising out of the application or use of any product or circuit described herein, neither does it convey any license under its patent rights nor the rights of others.

AMCC reserves the right to ship devices of higher grade in place of those of lower grade.

AMCC SEMICONDUCTOR PRODUCTS ARE NOT DESIGNED, INTENDED, AUTHORIZED, OR WARRANTED TO BE SUITABLE FOR USE IN LIFE-SUPPORT APPLICATIONS, DEVICES OR SYSTEMS OR OTHER CRITICAL APPLICATIONS.

AMCC is a registered trademark of Applied Micro Circuits Corporation.
Copyright © 1999 Applied Micro Circuits Corporation