

FEATURES

- Complies with ANSI, Bellcore, and ITU-T specifications for jitter tolerance, jitter transfer and jitter generation
- On-chip high frequency PLL with internal loop filter for clock recovery
- Supports clock recovery for OC-12/STM-4 (622.08 Mbit/s) NRZ data
- 12.96 MHz reference frequency
- Lock detect—monitors run length and frequency
- 350mW typical power dissipation
- Low-jitter PECL interface
- On-chip crystal oscillator allows use of low cost reference crystal
- Micro-power Bipolar technology
- 5V supply
- Available in die form or 20 TSSOP package

GENERAL DESCRIPTION

The function of the S3025 clock recovery unit is to derive high speed timing signals for SONET/SDH-based equipment. The S3025 is implemented using AMCC's proven Phase Locked Loop (PLL) technology.

The S3025 receives an OC-12/STM-4 scrambled NRZ signal and recovers the clock from the data. The chip outputs a differential PECL bit clock and retimed data.

The S3025 utilizes an on-chip PLL which consists of a phase detector, a loop filter, and a voltage controlled oscillator (VCO). The phase detector compares the phase relationship between the VCO output and the serial data input. A loop filter converts the phase detector output into a smooth DC voltage, and the DC voltage is input to the VCO whose frequency is varied by this voltage. A block diagram is shown in Figure 2.

Figure 1. System Block Diagram

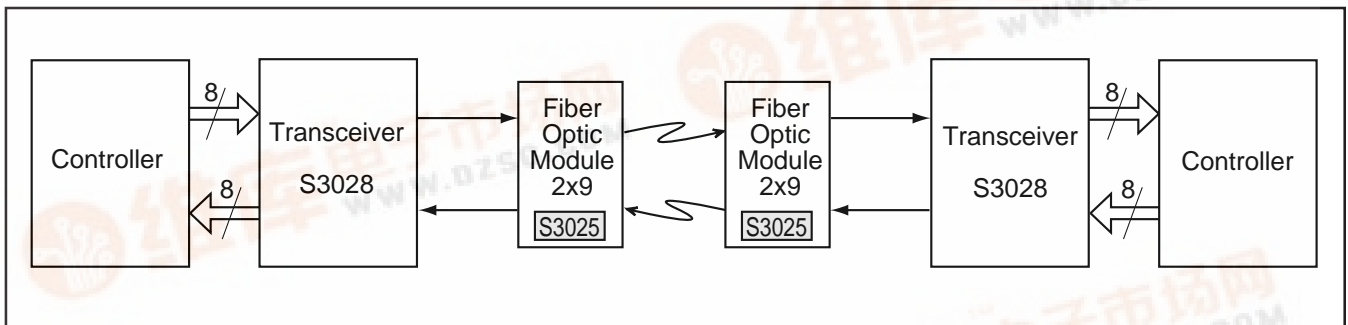
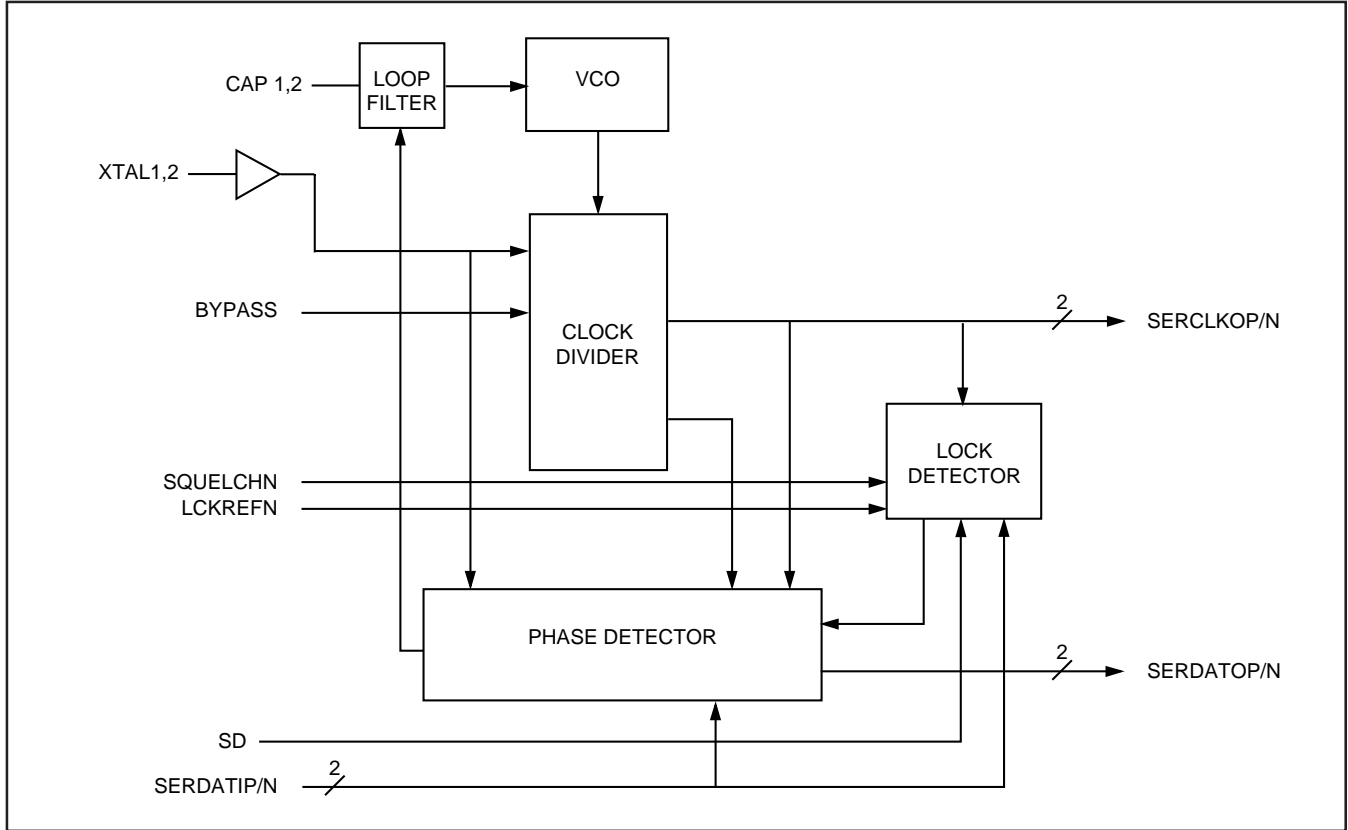

Figure 2. Functional Block Diagram



OVERVIEW

The S3025 supports clock recovery for the OC-12/STM-4 data rate. Differential serial data is input to the chip at the specified rate and clock recovery is performed on the incoming data stream. An external crystal is required to minimize the PLL lock time and provide a stable output clock source in the absence of serial input data. Retimed data and clock are output from the S3025.

CHARACTERISTICS

Performance

The S3025 PLL complies with the jitter specifications proposed for SONET/SDH equipment defined by the T1X1.6/91-022 document, when used with differential inputs and outputs as shown in Figure 3.

Jitter Transfer

Jitter transfer functions is defined as the ratio of jitter on the output OC-N/STS-N signal to the jitter applied on the input OC-N/STS-N signal versus frequency. Jitter transfer requirements are shown in Figure 5. The measurement condition is that input sinusoidal jitter up to the mask level in Figure 4 be applied for each of the OC-N/STS-N rates.

Input Jitter Tolerance

Input jitter tolerance is defined as the peak to peak amplitude of sinusoidal jitter applied on the input signal that causes an equivalent 1 dB optical/electrical power penalty. SONET input jitter tolerance requirements are shown in Figure 4. The measurement condition is the input jitter amplitude which causes an equivalent of 1 dB power penalty.

Serial Data Output Set-up and Hold Time

The output set-up and hold times are represented by the waveforms shown in Figure 3.

Jitter Generation

The jitter of the serial clock and serial data outputs shall not exceed .01 U.I. when a serial data input with less than 14ps rms jitter is presented to the serial data inputs.

Figure 3. Clock Output to Data Transition Delay

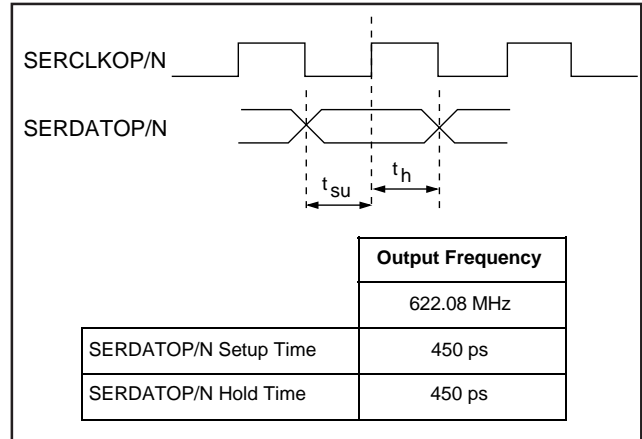

Figure 4. Input Jitter Tolerance Specification

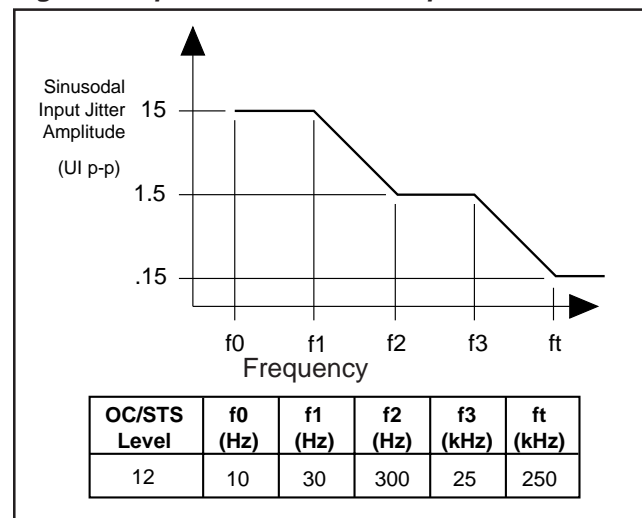
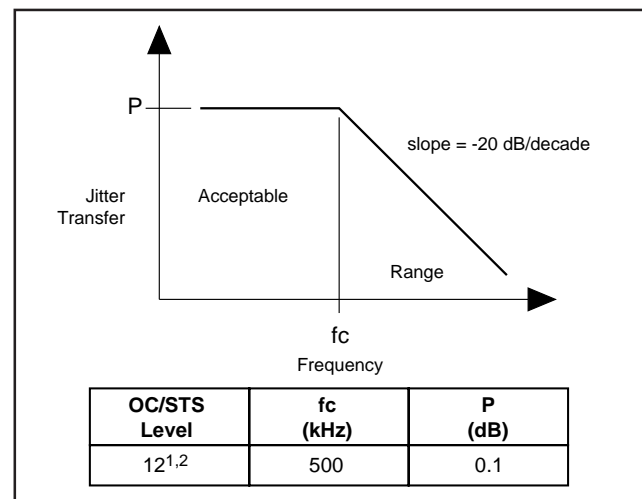

Figure 5. Jitter Transfer Specification



1. Bellcore Specifications: TR-NWT-000253, Issue 2, December 1991.
 2. CCITT Recommendations: G.958.

**S3025****SONET/SDH/ATM CLOCK RECOVERY UNIT****S3025 Pin Assignment and Descriptions**

Pin Name	Level	I/O	Pin #	Description
SERDATIP SERDATIN	Diff. PECL	I	2 3	Serial data in. A clock is recovered from transitions on these inputs.
BYPASS	TTL	I	16	Bypass enable, active high. Used during production test to bypass the VCO in the PLL. Tie to ground for normal operation.
SD	PECL	I	15	Signal detect, active high. A single-ended 10K PECL input to be driven by the external optical receiver module to indicate a loss of received optical power. When SD is inactive, the PLL will be forced to lock to the XTAL1, 2 inputs and the SERDATOP/N output will be held in the logic low state. See Table 1. When SD is active, data on the SERDATIP/N pins will be processed normally.
XTAL1 XTAL2	Analog	I	6 7	External crystal. A series resonant crystal is connected to these pins. The crystal is used to establish the initial operating frequency of the clock recovery PLL and also is used as a standby clock in the absence of data or during reset.
CAP1 CAP2	–	I	18 17	The loop filter capacitor is connected to these pins. The capacitor value should be 1.0 μ f \pm 10% tolerance, X7R dielectric.
SQUELCHN	TTL	I	5	Clock squelch, active low. When active, the serial clock output will be forced to lock to the local reference clock input [XTAL1,2] and the SERDATOP/N output will be held in the logic low state. See Table 1.
LCKREFN	TTL	I	8	Lock to reference, active low. When active, the serial clock output will be forced to lock to the local reference clock input [XTAL1,2].
SERDATOP SERDATON	Diff. PECL	O	14 13	Serial data out signal that is the delayed version of the incoming data stream (SERDATI) updated on the falling edge of Serial Clock Out (SERCLKOP).
SERCLKOP SERCLKON	Diff. PECL	O	12 11	Serial clock out signal that is phase aligned with Serial Data Out (SERDATOP/N). (See Figure 3.)
DGND	GND		9	Digital Ground (0V)
DVCC	+5V		10	Digital Power Supply (+5V)
AGND	GND		4, 19	Analog Ground (0V)
AVCC	+5V		1, 20	Analog Power Supply (+5V)

Figure 6. S3025A TSSOP Package

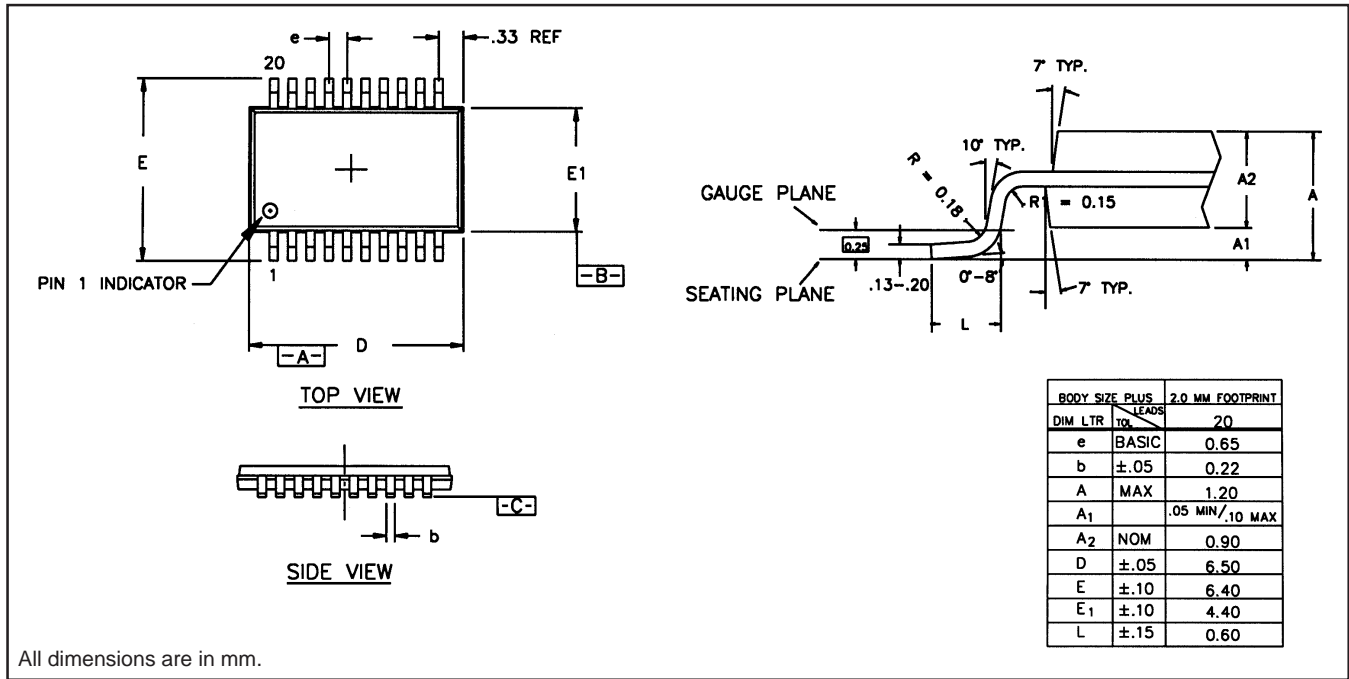

Table 1. Clock Squelch Enable Function

			SQUELCHN ACTIVE		SQUELCHN INACTIVE	
SD	LCKREFN	*LOCK DETECT	SERCLKOP/N	SERDATP/N	SERCLKOP/N	SERDATP/N
X	X	0	0	—	Active	0
X	0	X	0	0	Active	0
0	X	X	0	0	Active	0
1	1	1	Active	Active	Active	Active

1. LOCKDET is not a pin. This column indicates the state of the internal Lock Detect state machine. (See Lock Detect description.)

Performance Specifications

Parameter	Min	Typ	Max	Units	Condition
Nominal VCO Center Frequency		622.08		MHz	
Reference Clock Frequency Tolerance Clock Recovery ¹	-250		+250	ppm	
OC-12/STS-12 Capture Range		±500ppm			With respect to fixed reference frequency
Clock Output Duty Cycle	45		55	% of UI	Minimum transition density of 20%
Acquisition Lock Time ¹ OC-12/STS-12			16	µsec	With device already powered up and valid REFCLK.
PECL Output Rise & Fall Times			600	ps	10% to 90%, 50 to -2V equivalent load, 5 pf cap
SERCLKOP/N Jitter Generation		.005	.01	U.I.	With less than 14ps rms jitter on SERDATIP/N data inputs
OC-12/STS-12 Jitter Tolerance ¹	0.5			U.I.	Sinusoidal input jitter. Amplitude on SERDATIP/N data inputs from 250KHz to 5MHz.

1. Guaranteed but not tested.

Absolute Maximum Ratings

Parameter	Min	Typ	Max	Unit
Case Temperature under Bias	-55		+125	° C
Junction Temperature under Bias	-55		+150	° C
Storage Temperature	-65		+150	° C
Voltage on VCC with Respect to GND	-0.5		+7.0	V
Voltage on any TTL Input Pin	-0.5		+5.5	V
Voltage on any PECL Input Pin	VCC -2.0		VCC	V
TTL Output Sink Current			20	mA
TTL Output Source Current			10	mA
High Speed PECL Output Source Current			50	mA
Static Discharge Voltage		500		V

Recommended Operating Conditions

Parameter	Min	Typ	Max	Unit
Ambient Temperature under Bias (industrial)	-40		+85	° C
Ambient Temperature under Bias (commercial)	0		+70	° C
Junction Temperature under Bias	-10		+130	° C
Voltage on VCC with Respect to GND	4.75	5.0	5.25	V
Voltage on Any TTL Input Pin	0.0		VCC	V
Voltage on Any PECL Input Pin	VCC -2		VCC	V
PECL Output Source Current (50 to Vcc-2V)		14	25	mA
ICC Supply Current		70	100	mA

TTL Input/Output DC Characteristics²

 (T_A = -40°C to +85°C, V_{CC} = 5 V ±5%)

Symbol	Parameter	Test Conditions	Min	Max	Unit
V _{IL} ¹	Input LOW Voltage	Guaranteed Input LOW Voltage for all inputs		0.8	Volts
V _{IH} ¹	Input HIGH Voltage	Guaranteed Input HIGH Voltage for all inputs	2.0		Volts
I _{IL}	Input LOW Current	V _{CC} = MAX, V _{IN} = 0.5V	-400.0		uA
I _{IH}	Input HIGH Current	V _{CC} = MAX, V _{IN} = 2.7V		50.0	uA
I _I	Input HIGH Current at Max VCC	V _{CC} = MAX, V _{IN} = 5.25V		1.0	mA
I _{OS}	Output Short Circuit Current	V _{CC} = MAX, V _{OUT} = 0.5V	-100.0	-25.0	mA
V _{IK}	Input Clamp Diode Voltage	V _{CC} = MIN, I _{IN} = -18.0mA	-1.2		Volts
V _{OL}	TTL Output LOW Voltage	V _{CC} = MIN, I _{OL} = 8mA		0.5	Volts
V _{OH}	TTL Output HIGH Voltage	V _{CC} = MIN, I _{OH} = -1.0mA	2.4		Volts

1. These input levels provide a zero-noise immunity and should only be tested in a static, noise-free environment.

PECL Input/Output DC Characteristics

 (T_A = -40°C to +85°C, V_{CC} = 5 V ±5%)

Symbol	Parameter	Min	Typ	Max	Unit	Conditions
V _{IL}	Input LOW Voltage	V _{CC} -2.000		V _{CC} -1.441	Volts	Guaranteed Input LOW Voltage for single-ended inputs
V _{IH}	Input HIGH Voltage	V _{CC} -1.225		V _{CC} -0.570	Volts	Guaranteed Input HIGH Voltage for single-ended inputs
V _{IL}	Input LOW Voltage	V _{CC} -2.000		V _{CC} -0.700	Volts	Guaranteed Input LOW Voltage for differential inputs
V _{IH}	Input HIGH Voltage	V _{CC} -1.750		V _{CC} -0.450	Volts	Guaranteed Input HIGH Voltage for differential inputs
V _{ID}	Input Diff. Voltage	0.250	0.500	1.400	Volts	Differential Input Voltage
I _{IH}	Input High Current	-0.500		20.000	μA	V _{ID} = 500mV
I _{IL}	Input Low Current	-0.500		20.000	μA	V _{ID} = 500mV
V _{OL}	Output LOW Voltage	V _{CC} -2.000		V _{CC} -1.500	Volts	50 ohm termination to V _{CC} -2V
V _{OH}	Output HIGH Voltage	V _{CC} -1.110		V _{CC} -0.670	Volts	50 ohm termination to V _{CC} -2V
V _{OD}	Output Diff. Voltage	0.390		1.330	Volts	Differential Output Voltage

External Series Resonant Crystal Specifications

Parameter	Min	Typ	Max	Units	Condition
Frequency		12.96		MHz	
Accuracy	-500		+500	ppm	

Ordering Information

GRADE	PART	PACKAGE
S-commercial/ Industrial	3025	A – 20 TSSOP

X
Grade

XXXX
Part number

- **X**
Package



Applied Micro Circuits Corporation • 6290 Sequence Dr., San Diego, CA 92121

Phone: (619) 450-9333 • (800)755-2622 • Fax: (619) 450-9885

<http://www.amcc.com>

AMCC reserves the right to make changes to its products or to discontinue any semiconductor product or service without notice, and advises its customers to obtain the latest version of relevant information to verify, before placing orders, that the information being relied on is current.

AMCC does not assume any liability arising out of the application or use of any product or circuit described herein, neither does it convey any license under its patent rights nor the rights of others.

AMCC reserves the right to ship devices of higher grade in place of those of lower grade.

AMCC SEMICONDUCTOR PRODUCTS ARE NOT DESIGNED, INTENDED, AUTHORIZED, OR WARRANTED TO BE SUITABLE FOR USE IN LIFE-SUPPORT APPLICATIONS, DEVICES OR SYSTEMS OR OTHER CRITICAL APPLICATIONS.

AMCC is a registered trademark of Applied Micro Circuits Corporation.
Copyright © 1997 Applied Micro Circuits Corporation

June 2, 1997