

Real time clock module

SERIAL-INTERFACE REAL TIME CLOCK MODULE

# RTC-4553

- Built-in crystal unit allows adjustment-free efficient operation.
- The small package makes high-density mounting possible. (SOP 14-pin)
- Automatic calendar function (year, month, day, day of the week, hour, minute, second).
- Automatic leap year correction. (up to 2099)
- Built-in 30 x 4-bit S-RAM.
- High-speed access.
- Reference pulse output. (1024 Hz, 1/10 Hz)
- Low current consumption. (1  $\mu$ A typical)
- Similar mounting method to that used for universal type SMD IC

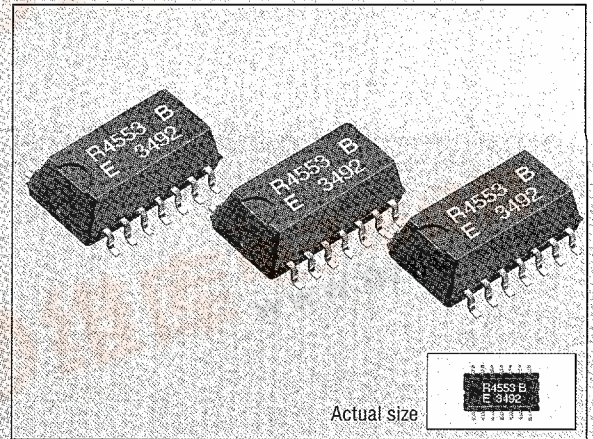

■ Specifications (characteristics)  
■ Absolute Max. rating

Item	Symbol	Condition	Min.	Max.	Unit
Supply voltage	$V_{DD}$	$V_{DD}$ -GND		+6.0	
Input voltage	$V_{IN}$	$S_{IN}, SCK, WR, CS_0, CS_1$	-0.3	$V_{DD}+0.3$	V
Output voltage	$V_{OUT}$	$S_{OUT}, T_{POUT}$			
Storage temperature	$T_{STG}$	Stored without tape & reel	-55	+125	$^{\circ}$ C
Soldering conditions	$T_{SOL}$		Twice at under 260 $^{\circ}$ C within 10 sec. or under 230 $^{\circ}$ C within 3 min.		

■ Operating range

Item	Symbol	Condition	Min.	Typ.	Max.	Unit
Operating voltage	$V_{DD}$		2.7	5.0	5.5	V
Operating temperature	$T_{OPR}$		-30		+70	$^{\circ}$ C

■ Frequency characteristics

Item	Symbol	Condition	Range	Unit	
Frequency tolerance	$\Delta f/f_0$	$T_a=25^{\circ}$ C, $V_{DD}=5$ V	AA	5 $\pm$ 5	ppm
			A	5 $\pm$ 10	
			B	5 $\pm$ 20	
Frequency temperature characteristics	$T_{OP}$	$T_a=-10$ to 70 $^{\circ}$ C, $V_{DD}=5$ V Reference at 25 $^{\circ}$ C	+10 -120		
Frequency voltage characteristics	$f_V$	$T_a=Fix$ , $V_{DD}=2$ to 5.5V Reference at 5V	$\pm$ 5		
Aging	$f_a$	$T_a=25^{\circ}$ C, $V_{DD}=5$ V, first year		ppm/year	

■ DC characteristics

●  $V_{DD}=5V\pm 10\%$  (GND=0V,  $T_a=-30^{\circ}$ C to +70 $^{\circ}$ C)

Item	Symbol	Condition	Min.	Typ.	Max.	Unit
Data holding voltage	$V_{DH}$		2.0		5.5	V
Current consumption	$I_{DD1}$	$SCK=500$ kHz			100	$\mu$ A
	$I_{DD2}$	$SCK=0$ Hz		1.0	3.0	
Output voltage	$V_{OH}$	$I_{OH}=-400\mu$ A	$V_{DD}-0.4$			V
	$V_{OL}$	$I_{OL}=1.6$ mA			0.4	
Off leak current	$I_{OZH}$	$V_{OUT}=5.5$ V	-2.0		2.0	$\mu$ A
	$I_{OZL}$	$V_{OUT}=0$ V				
Input voltage	$V_{IH}$		$4/5 V_{DD}$			V
	$V_{IL}$				$1/5 V_{DD}$	
Input current	$I_{IH}$	$V_{IN}=5.5$ V	-2.0		2.0	$\mu$ A
	$I_{IL}$	$V_{IN}=0$ V				

■ Terminal connection

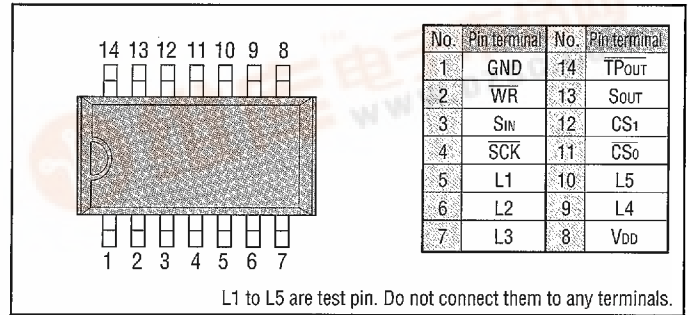

■ External dimensions

(Unit: mm)

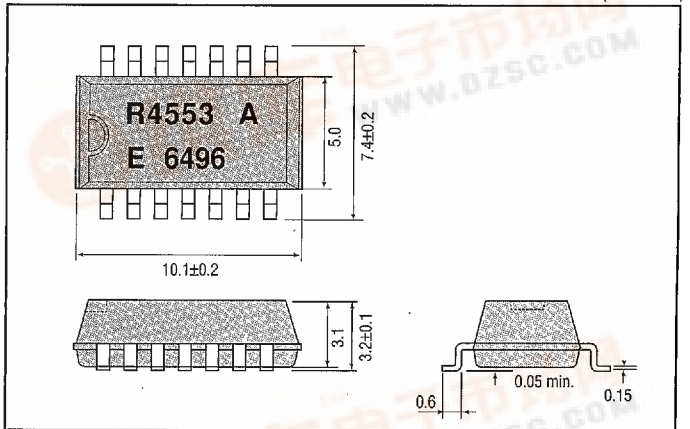

●  $V_{DD}=3V\pm 10\%$  (GND=0V,  $T_a=-30^{\circ}$ C to +70 $^{\circ}$ C)

Item	Symbol	Condition	Min.	Typ.	Max.	Unit
Data holding voltage	$V_{DH}$		2.0		3.3	V
Current consumption	$I_{DD1}$	$SCK=300$ kHz			100	$\mu$ A
	$I_{DD2}$	$SCK=0$ Hz		1.0	3.0	
Output voltage	$V_{OH}$	$I_{OH}=-400\mu$ A	$V_{DD}-0.4$			V
	$V_{OL}$	$I_{OL}=1.6$ mA			0.4	
Off leak current	$I_{OZH}$	$V_{OUT}=3.3$ V	-2.0		2.0	$\mu$ A
	$I_{OZL}$	$V_{OUT}=0$ V				
Input voltage	$V_{IH}$		$4/5 V_{DD}$			V
	$V_{IL}$				$1/5 V_{DD}$	
Input current	$I_{IH}$	$V_{IN}=3.3$ V	-2.0		2.0	$\mu$ A
	$I_{IL}$	$V_{IN}=0$ V				

Register table

Address					MODE 0					MODE 1				MODE 2				
					Register symbol	Counter control register				User RAM Domain 1				User RAM Domain 2				
A <sub>3</sub>	A <sub>2</sub>	A <sub>1</sub>	A <sub>0</sub>	D <sub>3</sub>		D <sub>2</sub>	D <sub>1</sub>	D <sub>0</sub>	Register name				D <sub>3</sub>	D <sub>2</sub>	D <sub>1</sub>	D <sub>0</sub>		
0	0	0	0	0	S <sub>1</sub>	S <sub>8</sub>	S <sub>4</sub>	S <sub>2</sub>	S <sub>1</sub>	1-second digit register	RA <sub>3</sub>	RA <sub>2</sub>	RA <sub>1</sub>	RA <sub>0</sub>	RA <sub>63</sub>	RA <sub>62</sub>	RA <sub>61</sub>	RA <sub>60</sub>
1	0	0	0	1	S <sub>10</sub>	0	S <sub>40</sub>	S <sub>20</sub>	S <sub>10</sub>	10-second digit register	RA <sub>7</sub>	RA <sub>6</sub>	RA <sub>5</sub>	RA <sub>4</sub>	RA <sub>67</sub>	RA <sub>66</sub>	RA <sub>65</sub>	RA <sub>64</sub>
2	0	0	1	0	M <sub>1</sub>	m <sub>8</sub>	m <sub>4</sub>	m <sub>2</sub>	m <sub>1</sub>	1-minute digit register	RA <sub>11</sub>	RA <sub>10</sub>	RA <sub>9</sub>	RA <sub>8</sub>	RA <sub>71</sub>	RA <sub>70</sub>	RA <sub>69</sub>	RA <sub>68</sub>
3	0	0	1	1	M <sub>10</sub>	0	m <sub>40</sub>	m <sub>20</sub>	m <sub>10</sub>	10-minute digit register	RA <sub>15</sub>	RA <sub>14</sub>	RA <sub>13</sub>	RA <sub>12</sub>	RA <sub>75</sub>	RA <sub>74</sub>	RA <sub>73</sub>	RA <sub>72</sub>
4	0	1	0	0	H <sub>1</sub>	h <sub>8</sub>	h <sub>4</sub>	h <sub>2</sub>	h <sub>1</sub>	1-hour digit register	RA <sub>19</sub>	RA <sub>18</sub>	RA <sub>17</sub>	RA <sub>16</sub>	RA <sub>79</sub>	RA <sub>78</sub>	RA <sub>77</sub>	RA <sub>76</sub>
5	0	1	0	1	H <sub>10</sub>	PM/AM	0	h <sub>20</sub>	h <sub>10</sub>	10-hour digit register	RA <sub>23</sub>	RA <sub>22</sub>	RA <sub>21</sub>	RA <sub>20</sub>	RA <sub>83</sub>	RA <sub>82</sub>	RA <sub>81</sub>	RA <sub>80</sub>
6	0	1	1	0	W	0	w <sub>4</sub>	w <sub>2</sub>	w <sub>1</sub>	Day of the week digit register	RA <sub>27</sub>	RA <sub>26</sub>	RA <sub>25</sub>	RA <sub>24</sub>	RA <sub>87</sub>	RA <sub>86</sub>	RA <sub>85</sub>	RA <sub>84</sub>
7	0	1	1	1	D <sub>1</sub>	d <sub>8</sub>	d <sub>4</sub>	d <sub>2</sub>	d <sub>1</sub>	1-day digit register	RA <sub>31</sub>	RA <sub>30</sub>	RA <sub>29</sub>	RA <sub>28</sub>	RA <sub>91</sub>	RA <sub>90</sub>	RA <sub>89</sub>	RA <sub>88</sub>
8	1	0	0	0	D <sub>10</sub>	0	0	d <sub>20</sub>	d <sub>10</sub>	10-day digit register	RA <sub>35</sub>	RA <sub>34</sub>	RA <sub>33</sub>	RA <sub>32</sub>	RA <sub>95</sub>	RA <sub>94</sub>	RA <sub>93</sub>	RA <sub>92</sub>
9	1	0	0	1	MO <sub>1</sub>	m <sub>08</sub>	m <sub>04</sub>	m <sub>02</sub>	m <sub>01</sub>	1-month digit register	RA <sub>39</sub>	RA <sub>38</sub>	RA <sub>37</sub>	RA <sub>36</sub>	RA <sub>99</sub>	RA <sub>98</sub>	RA <sub>97</sub>	RA <sub>96</sub>
A	1	0	1	0	MO <sub>10</sub>	0	0	0	m <sub>010</sub>	10-month digit register	RA <sub>43</sub>	RA <sub>42</sub>	RA <sub>41</sub>	RA <sub>40</sub>	RA <sub>103</sub>	RA <sub>102</sub>	RA <sub>101</sub>	RA <sub>100</sub>
B	1	0	1	1	Y <sub>1</sub>	y <sub>8</sub>	y <sub>4</sub>	y <sub>2</sub>	y <sub>1</sub>	1-year digit register	RA <sub>47</sub>	RA <sub>46</sub>	RA <sub>45</sub>	RA <sub>44</sub>	RA <sub>107</sub>	RA <sub>106</sub>	RA <sub>105</sub>	RA <sub>104</sub>
C	1	1	0	0	Y <sub>10</sub>	y <sub>80</sub>	y <sub>40</sub>	y <sub>20</sub>	y <sub>10</sub>	10-year digit register	RA <sub>51</sub>	RA <sub>50</sub>	RA <sub>49</sub>	RA <sub>48</sub>	RA <sub>111</sub>	RA <sub>110</sub>	RA <sub>109</sub>	RA <sub>108</sub>
D	1	1	0	1	C <sub>1</sub>	TPS	30ADJ	CNTR	24/12	Control register 1	RA <sub>55</sub>	RA <sub>54</sub>	RA <sub>53</sub>	RA <sub>52</sub>	RA <sub>115</sub>	RA <sub>114</sub>	RA <sub>113</sub>	RA <sub>112</sub>
E	1	1	1	0	C <sub>2</sub>	BUSY	PONC	—	*	Control register 2	RA <sub>59</sub>	RA <sub>58</sub>	RA <sub>57</sub>	RA <sub>56</sub>	RA <sub>119</sub>	RA <sub>118</sub>	RA <sub>117</sub>	RA <sub>116</sub>
F	1	1	1	1	C <sub>3</sub>	SYSR	TEST	MS <sub>1</sub>	MS <sub>0</sub>	Control register 3	Same as MODE 0				Same as MODE 0			

Note: \* TEST bit should be "0".

Switching characteristics (T<sub>a</sub>=-30°C to +70°C, V<sub>DD</sub>=5V±10%, GND=0V)

Item	Symbol	Condition	Min.	Typ.	Max.	Unit
SCK input frequency	f <sub>sck</sub>	—	—	—	500	kHz
SCK "L" time	t <sub>wSCKL</sub>	—	—	—	—	—
SCK "H" time	t <sub>wSCKH</sub>	—	1.0	—	—	—
SCK pause time	t <sub>ps</sub>	—	—	—	—	—
CS <sub>0</sub> setup time	t <sub>sCS</sub>	—	0	—	—	μs
CS <sub>0</sub> hold time	t <sub>hCS</sub>	—	0.5	—	—	
S <sub>in</sub> data setup time	t <sub>sD</sub>	—	0.2	—	—	ns
S <sub>in</sub> data Hold time	t <sub>hD</sub>	—	—	—	—	
WR setup time	t <sub>sWR</sub>	—	1.0	—	—	ns
WR hold time	t <sub>hWR</sub>	—	0.5	—	—	
Sour delay time	t <sub>dsO</sub>	—	—	150	500	ns
CS <sub>0</sub> and CS <sub>1</sub> enable to Sour output	t <sub>dsZ1</sub>	C <sub>L</sub> =100pF	—	—	100	
CS <sub>0</sub> disable to Sour high Z	t <sub>dsZ2</sub>		—	—	100	
CS <sub>1</sub> enable to Sour output	t <sub>dpZ1</sub>		—	—	—	
CS <sub>1</sub> enable to Sour high Z	t <sub>dpZ2</sub>		—	—	—	

Timing chart

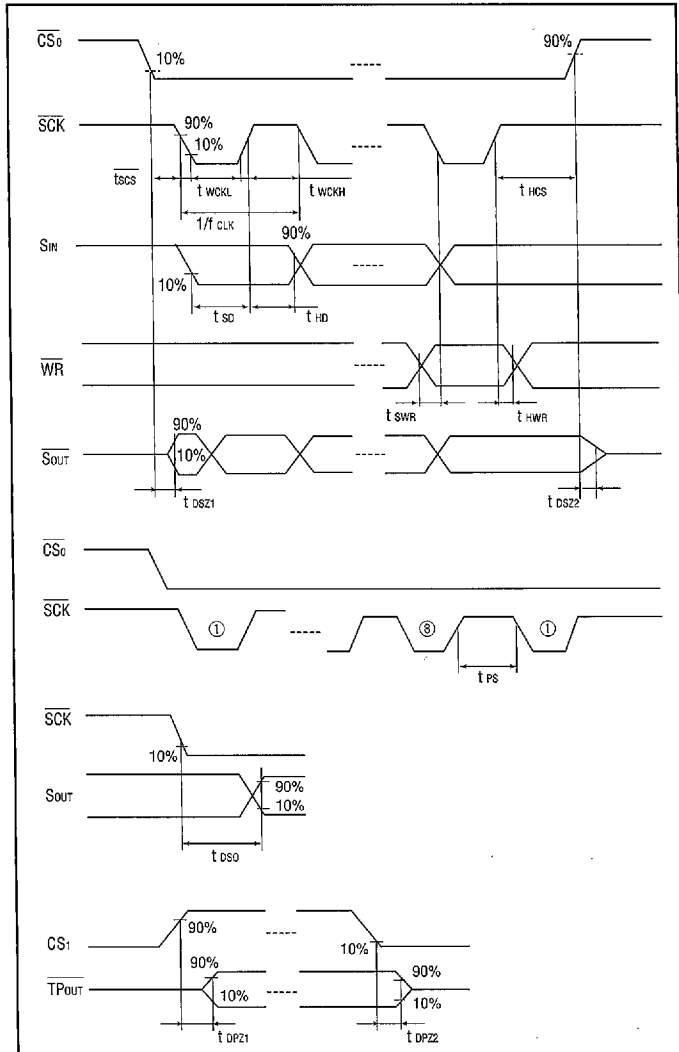

Block diagram

