



RFS1003

5.1-5.9 GHz U-NII Power Amplifier

Applications

- U-NII fixed-wireless CPE
- 5 GHz ISM band wireless equipment
- WLAN/802.11a/HIPERLAN/2

Product Description

The RFS1003 power amplifier is a high-power, high-performance GaAs MESFET IC designed for use in transmit applications in the 5.1-5.9 GHz frequency band. With a P1dB of 29 dBm, the device is ideal as a final stage for wireless applications requiring high transmit linearity. The input of the PA is matched to 50 ohms and the output can be easily matched for optimum linearity and power performance at the desired frequency of operation between 5.1 and 5.9 GHz.

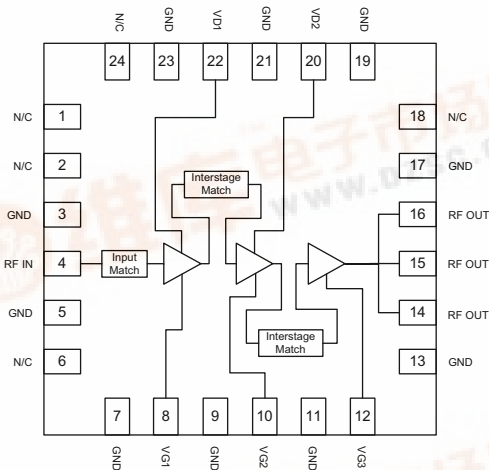

Product Features

- 29 dBm P1dB@7V
- 24 dBm P1dB@3V
- 20 dB gain
- Input matched to 50 ohms
- Simple output matching

Functional Block Diagram

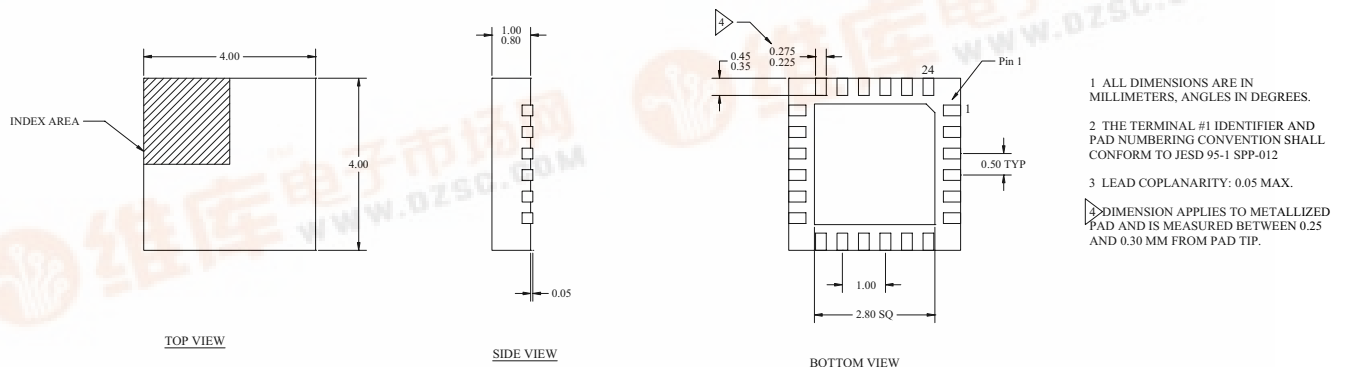

4x4 mm Package Outline



RFS1003

5.1-5.9 GHz U-NII Power Amplifier

Parameter ¹	Specification			Unit	Condition
	Min.	Typ.	Max.		
Overall					
Frequency Range	5150		5850	MHz	
Output P1dB		29		dBm	V _{DD} = 7V
		24		dBm	V _{DD} = 3V
Efficiency at P1dB		28		%	
Small Signal Gain		20		dB	P _{IN} = -20 dBm; V _{DD} = 7V
		21		dB	P _{IN} = -20 dBm; V _{DD} = 3V
Gain Flatness		±0.5		dB	Across 100 MHz Band
Harmonics					
2 nd Harmonic		-35		dBc	
3 rd Harmonic		-35		dBc	
Spurious (Stability) ²		-60		dBc/30 kHz	P _{IN} = -30 to +10 dBm
Reverse Isolation		50		dB	
Noise Figure		8.7		dB	
Input Return Loss	10	15		dB	
Output Return Loss		11		dB	
Power Supply					
Drain Operating Voltage	3		7	V	
Gate Operating Voltage		-1.1		V	
Current Consumption		400		mA	V _{DD} = 7V
		350		mA	V _{DD} = 3V
Gate Leakage Current		25		µA	

Note 1: Test Conditions: V_{DD} = 7.0V, P_{IN} = +10dBm, Freq. = 5850MHz, V_{GG} = -1.1 V, T = 25C.

Note 2: Load VSWR is set to 7:1 and the angle is varied 360 degrees.

Absolute Maximum Ratings

Parameter	Rating	Unit
DC Power Supply	8.0	V
DC Gate Voltage	-5.0 min, -0.5 max	V
DC Supply Current	1000	mA
Maximum RF input level	+13	dBm
Operating Ambient Temperature	-40 to +85	°C
Storage Temperature	-55 to +150	°C



Ordering Information

Part Number	Temp. Range (°C)	Package Description	Quantity
PRFS-1003-0EVL	-40 to +85	Evaluation Board	1
PRFS-1003-0005	-40 to +85	13" Reverse Tape/Reel	2500 pcs.
PRFS-1003-0006	-40 to +85	13" Tape/Reel	2500 pcs.
PRFS-1003-0007	-40 to +85	7" Reverse Tape/Reel	1000 pcs.
PRFS-1003-0008	-40 to +85	7" Tape/Reel	1000 pcs.
PRFS-1003-0009	-40 to +85	Bulk – 4x4 mm 24-pin LPCC	1-999 pcs.

NOTES



ANADIGICS, Inc.

141 Mount Bethel Road
Warren, New Jersey 07059, U.S.A.
Tel: +1(908)668-5000
Fax: +1(908)668-5132

URL: <http://www.anadigics.com>
E-mail: Mktg@anadigics.com

IMPORTANT NOTICE

ANADIGICS, Inc. reserves the right to make changes to its products or to discontinue any product at any time without notice. The product specifications contained in Advanced Product Information sheets and Preliminary Data Sheets are subject to change prior to a product's formal introduction. Information in Data Sheets have been carefully checked and are assumed to be reliable; however, ANADIGICS assumes no responsibilities for inaccuracies. ANADIGICS strongly urges customers to verify that the information they are using is current before placing orders.

WARNING

ANADIGICS products are not intended for use in life support appliances, devices or systems. Use of an ANADIGICS product in any such application without written consent is prohibited.