



500W with PFC and Parallel Function

PSP-500 series



■ Features :

- Universal AC input / Full range
- Built-in active PFC function, PF>0.95
- Protections: Short circuit/Over load/Over voltage/Over temperature
- Foced air cooling by built-in DC fan
- Current sharing up to 2000W(3+1)
- With power good and fail signal output
- Built-in remote ON-OFF control
- Built-in remote sense function
- 3 years warranty



SPECIFICATION

MODEL	PSP-500-5	PSP-500-12	PSP-500-13.5	PSP-500-15	PSP-500-24	PSP-500-27	PSP-500-48	
OUTPUT	DC VOLTAGE	5V	12V	13.5V	15V	24V	27V	48V
	RATED CURRENT	80A	41.5A	37A	33A	20.8A	18.5A	10.5A
	CURRENT RANGE	0 ~ 80A	0 ~ 41.5A	0 ~ 37A	0 ~ 33A	0 ~ 20.8A	0 ~ 18.5A	0 ~ 10.5A
	RATED POWER	400W	498W	499.5W	495W	499.2W	499.5W	504W
	RIPPLE & NOISE (max.) Note.2	100mVp-p	150mVp-p	150mVp-p	150mVp-p	150mVp-p	150mVp-p	200mVp-p
	VOLTAGE ADJ. RANGE	4.75 ~ 5.5V	10 ~ 13.2V	12 ~ 15V	13.5 ~ 18V	20 ~ 26.4V	24 ~ 30V	41 ~ 56V
	VOLTAGE TOLERANCE Note.3	±2.0%	±1.0%	±1.0%	±1.0%	±1.0%	±1.0%	±1.0%
	LINE REGULATION	±0.5%	±0.3%	±0.3%	±0.3%	±0.2%	±0.2%	±0.2%
	LOAD REGULATION	±2.0%	±0.5%	±0.5%	±0.5%	±0.5%	±0.5%	±0.5%
	SETUP, RISE TIME	1500ms, 50ms at full load						
HOLD TIME (Typ.)	24ms at full load							
INPUT	VOLTAGE RANGE Note.6	90 ~ 264VAC	127 ~ 370VDC					
	FREQUENCY RANGE	47 ~ 63Hz						
	POWER FACTOR (Typ.)	0.95/230VAC 0.98/100VAC at full load						
	EFFICIENCY (Typ.)	76%	82%	82%	82%	84%	84%	86%
	AC CURRENT (Typ.)	7A/115VAC	3.5A/230VAC					
	INRUSH CURRENT (Typ.)	20A/115VAC	40A/230VAC					
LEAKAGE CURRENT	<1mA / 240VAC							
PROTECTION	OVER LOAD	110 ~ 125% rated output power Protection type : Constant current limiting, recovers automatically after fault condition is removed						
	OVER VOLTAGE	5.75 ~ 6.75V	13.8 ~ 16.2V	15.5 ~ 18.2V	18 ~ 21V	27.6 ~ 32.4V	31 ~ 36.5V	57.6 ~ 67.2V
	OVER TEMPERATURE	RTH2 ≥ 95°C Detect on heatsink of Q1,Q7 power transistor & L3 output choke Protection type : Shut down o/p voltage, recovers automatically after temperature goes down						
FUNCTION	REMOTE CONTROL	RC+/RC-: 0 ~ 0.8V=power on ; 4 ~ 10V=power off sink current <4 ~ 10mA						
ENVIRONMENT	WORKING TEMP.	-10 ~ +60°C (Refer to output load derating curve)						
	WORKING HUMIDITY	20 ~ 90% RH with 30CFM forced air non-condensing						
	STORAGE TEMP., HUMIDITY	-20 ~ +85°C, 10 ~ 95% RH						
	TEMP. COEFFICIENT	±0.03%/°C (0 ~ 50°C)						
	VIBRATION	10 ~ 500Hz, 2G 10min./1cycle, 60min. each along X, Y, Z axes						
SAFETY & EMC (Note 4)	SAFETY STANDARDS	UL60950-1, TUV EN60950-1 Approved						
	WITHSTAND VOLTAGE	I/P-O/P:3KVAC I/P-FG:1.5KVAC O/P-FG:0.5KVAC						
	ISOLATION RESISTANCE	I/P-O/P, I/P-FG, O/P-FG:100M Ohms/500VDC						
	EMI CONDUCTION & RADIATION	Compliance to EN55022 (CISPR22) Class B						
	HARMONIC CURRENT	Compliance to EN61000-3-2,-3						
	EMS IMMUNITY	Compliance to EN61000-4-2,3,4,5,6,8,11; ENV50204, EN55024, Light industry level, criteria A						
OTHERS	MTBF	130.1K hrs min. MIL-HDBK-217F (25°C)						
	DIMENSION	278*129*63.5mm (L*W*H)						
	PACKING	2.6Kg; 6pcs/15.7Kg/0.89CUFT						
NOTE	1. All parameters NOT specially mentioned are measured at 230VAC input, rated load and 25°C of ambient temperature. 2. Ripple & noise are measured at 20MHz of bandwidth by using a 12" twisted pair-wire terminated with a 0.1uf & 47uf parallel capacitor. 3. Tolerance : includes set up tolerance, line regulation and load regulation. 4. The power supply is considered a component which will be installed into a final equipment. The final equipment must be re-confirmed that it still meets EMC directives. 5. In parallel connection, maybe only one unit operated, if the total output load less than 5% of rated load condition. 6. Derating may be needed under low input voltages. Please check the derating curve for more details.							



Mechanical Specification

Case No. 919A Unit:mm

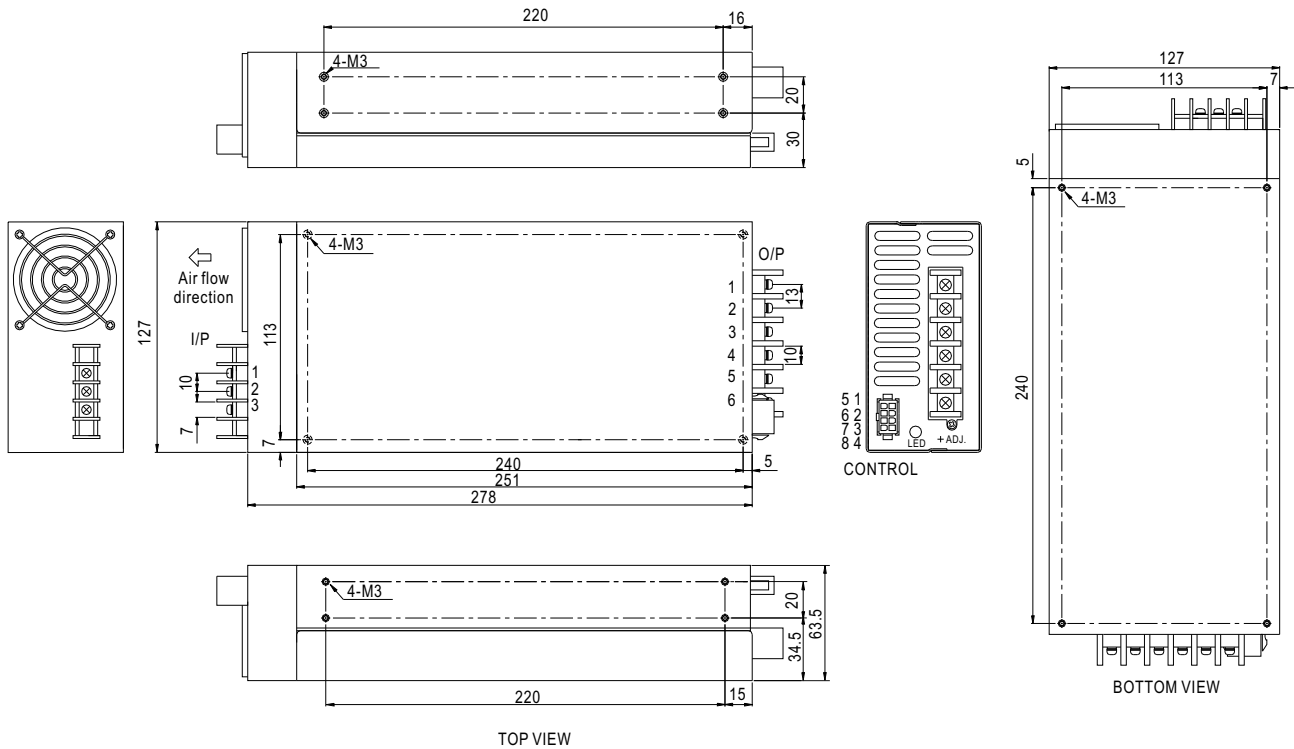

AC Input Terminal Pin. No. Assignment

Pin No.	Assignment
1	AC/L
2	AC/N
3	FG \perp

DC Output Terminal Pin. No Assignment

Pin No.	Assignment
1~3	DC OUTPUT +V
4~6	DC OUTPUT -V

Control Pin. No Assignment : MOLEX 5559-NP uses 5558 male crimp terminal

Pin No.	Assignment	Pin No.	Assignment	Mating connector	Terminal
1	P(Current share)	5	NC	MOLEX 5557-NR	MOLEX 5556 Female crimp Terminal receptacle
2	-S	6	PF(Power fail signal)		
3	G	7	+S		
4	RC-	8	RC+		

Derating Curve

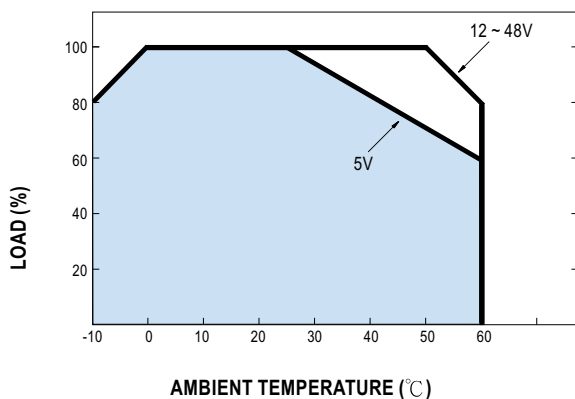

Output Derating VS Input Voltage

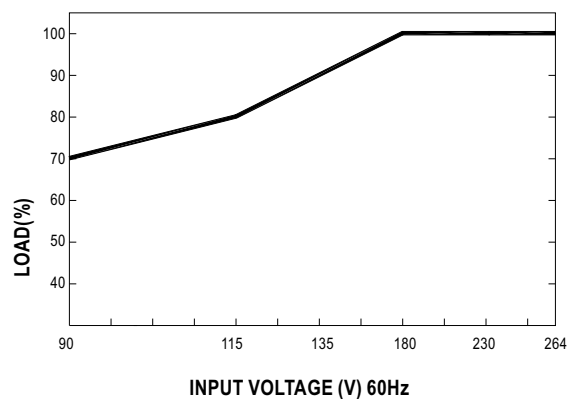

Control terminal instruction manual

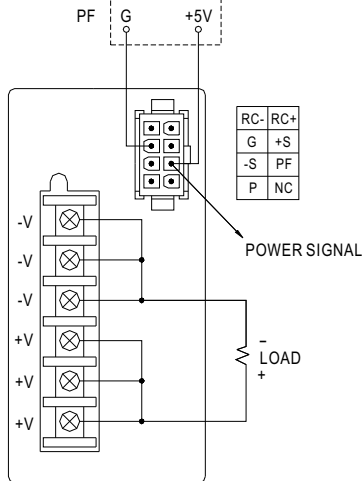

Power Fail Signal

PF Signal is the voltage difference between "G" and "PF" pin output

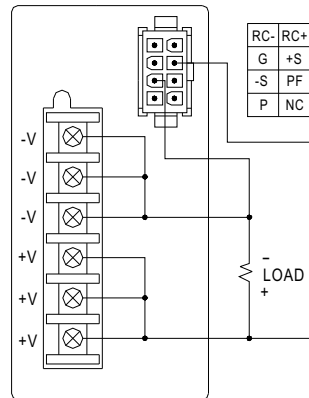

Remote Sensing

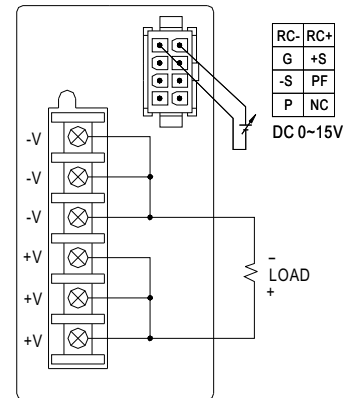

Remote Control

Power ON: When VRC+,RC-=0 ~ 0.8V or Open
Power OFF: When VRC+,RC-=4 ~ 10V

Parallel Operation

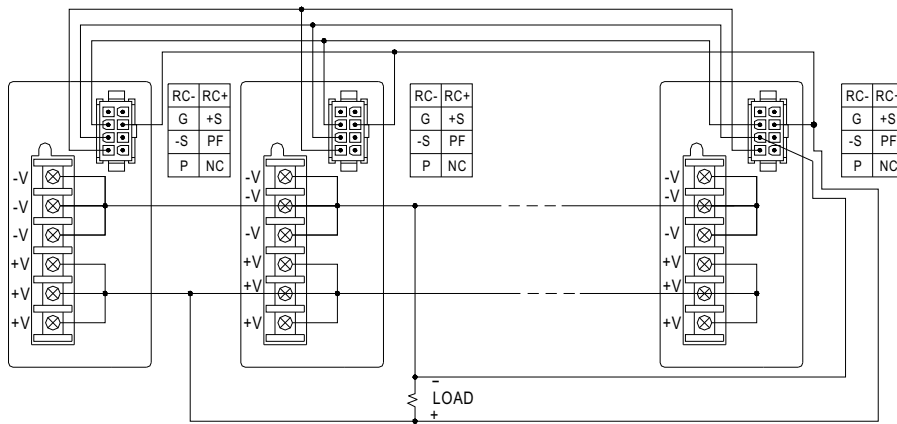

Parallel Operation With Remote Sensing

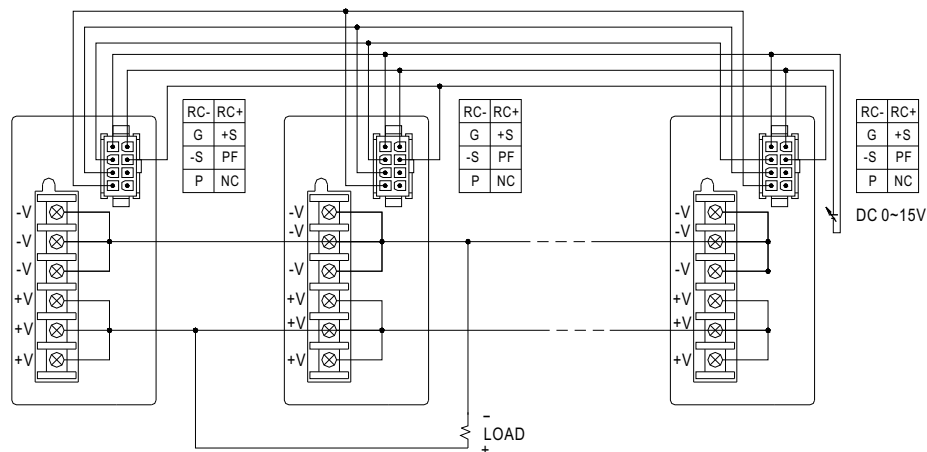

Parallel Operation With Remote Control