

Table of Contents		Page
1	Overview	3
1.1	Features	3
1.2	Pin Configuration	4
1.3	Pin Definitions and Functions	4
1.4	Functional Block Diagram	7
2	Circuit Description	8
3	Electrical Characteristics	16
3.1	Absolute Maximum Ratings	16
3.2	Typical Supply Current I_{DD}	17
3.3	AC/DC Characteristics	17
4	Package Outlines	32
4.1	Plastic-Package, P-TSSOP-16 (SMD)	32
4.2	Plastic-Package, P-DSO-14-1(SMD)	33



PAGE(S) INTENTIONALLY BLANK

PLL-Frequency Synthesizer

PMB 2306R/PMB 2306T

Versions 2.2

Bipolar IC

1 Overview

1.1 Features

- Low operating current consumption (typically 3.5 mA)
- High input sensitivity, high input frequencies (220 MHz)
- Extremely fast phase detector without dead zone
- Linearization of the phase detector output by current sources
- Synchronous programming of the counters (n-, n/a-, r-counters) and system parameters
- Fast modulus switchover for 65-MHz operation
- Switchable modulus trigger edge
- Large dividing ratios for small channel spacing
A scaler 0 to 127
N scaler 3 to 16.380
R scaler 3 to 65.535
- Serial control (3-wire bus: data, clock, enable) for fast programming ($f_{max} \sim 10$ MHz)
- Switchable polarity and phase detector current programmable
- 2 Multifunction outputs
- Digital phase detector output signals (e.g. for external charge pump)
- f_m, f_{vn} outputs of the R and N scalars
- Port 1 output (e.g. for standby of the prescaler)
- External current setting for PD output
- Lock detect output with gated anti-backlash pulse (quasi digital lock detect)

PMB 2306T



P-DSO-14

PMB 2306R



P-TSSOP-16

Type	Version	Ordering Code	Package
PMB 2306T	V2.2	Q67100-H6423	P-DSO-14 (SMD)
PMB 2306T	V2.2	Q67106-H6423	P-DSO-14 (SMD, Tape & Reel)
PMB 2306R	V2.2	Q67106-H6514 (T&R)	P-TSSOP-16 (SMD, T&R)

The PMB 2306T PLL is a high speed CMOS IC, especially designed for use in battery powered radio equipment and mobile telephones. The primary applications will be in digital systems e.g. GSM, PCN, ADC, JDC and DECT systems. The wide range of dividing ratios also allows application in modern analog systems.

1.2 Pin Configuration
(top view)

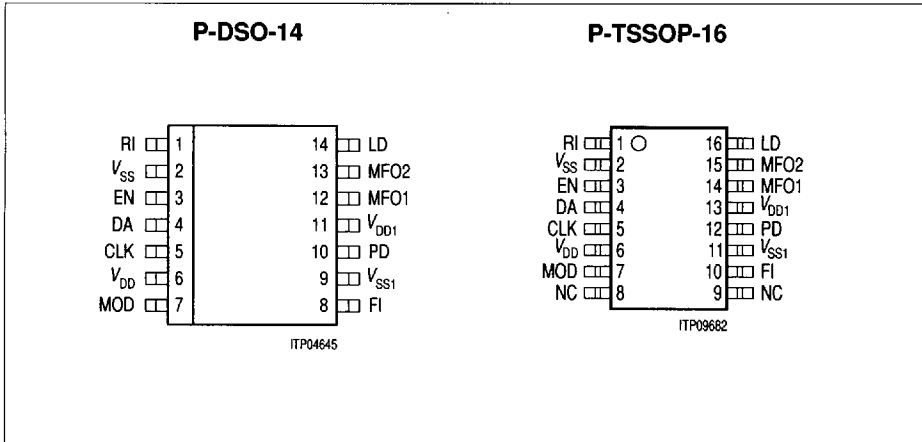

Figure 1

1.3 Pin Definitions and Functions

DSO-14	TSSOP-16	Symbol	Function
6	6	V_{DD}	Positive supply voltage for serial control logic.
2	2	V_{SS}	Ground for serial control logic.
11	13	V_{DD1}	Positive supply voltage for the preamplifiers, counters, phase detector and charge pump.
9	11	V_{SS1}	Ground for the preamplifiers, counters, phase detector and charge pump. (Note: The pins V_{DD} and V_{DD1} respectively V_{SS} and V_{SS1} have to have the same supply voltage.)
3	3	EN	3-Line Bus: Enable Enable line of the serial control with internal pull-up resistor. When EN = H the input signals CLK and DA are disabled internally. When EN = L the serial control is activated. The received data are transferred into the latches with the positive edge of the EN-signal.
4	4	DA	3-Line Bus: Data Serial data input with internal pull-up resistor. The last two bits before the EN-signal define the destination address. In a byte-oriented data structure the transmitted data have to end with the EN-signal, i.e. bits to be filled in (don't care) are transmitted first.

1.3 Pin Definitions and Functions (cont'd)

DSO-14	TSSOP-16	Symbol	Function
5	5	CLK	3-Line Bus: Clock Clock line with internal pull-up resistor. The serial data are read into the internal shift register with the positive edge (see pulse diagram for serial data control).
7	7	MOD	Modulus Control Output for external dual modulus prescaler. The modulus output is low at the beginning of the cycle. When the a-counter has reached its set value, MOD switches to high. When the n-counter has reached its set value, MOD switches to low again, and the cycle starts from the top. When the prescaler has the counter factor P or P + 1 (P for MOD = H, P + 1 for MOD = L), the overall scaling factor is NP + A. The value of the a-counter must be smaller than that of the n-counter. The trigger edge of the modulus signal to the input signal can be selected (see programming tables and MOD A, B) according to the needs of the prescaler. In single modulus operation and for standby operation in dual modulus operation, the output is low.
8	10	FI	VCO-Frequency Input with highly sensitive preamplifier for 14-bit n-counter and 7-bit a-counter. With small input signals AC coupling must be set up, where DC coupling can be used for large input signals.
1	1	RI	Reference Frequency Input with highly sensitive preamplifier for 16-bit r-counter. With small input signals AC coupling must be set up, where DC coupling can be used for large input signals.
10	12	PD	Phase Detector Tristate charge pump output. The integrated, positive and negative current sources can be programmed with respect to their current density by means of the serial control. Activation and deactivation depend on the phase relationship of the scaled-down input signals FI:N, RI:R. (See phase detector output waveforms.) frequency $f_V < f_R$ or f_V lagging: p-channel current source active frequency $f_V > f_R$ or f_R leading: n-channel current source active frequency $f_V = f_R$ and PLL locked: current sources are switched off, PD-output is tristate In standby mode the PD-output is set to tristate. The assignment of the current sources to the output signals of the phase detector can be swapped in it's polarity, i.e. the sign of the phase detector constant can be controlled.

1.3 Pin Definitions and Functions (cont'd)

DSO-14	TSSOP-16	Symbol	Function
14	16	LD	Lock Detector Output (open drain). Unipolar output of the phase detector in the form of a pulse-width modulated signal. The L-pulse width corresponds to the phase difference. Phase differences < 20 ns are not indicated due to gating of the anti-backlash impuls. In the locked state the LD-signal is at H-level. In standby mode the output is resistive. Only for ABL status 11 no gating of ABL impulse is performed.
12	14	MFO1	Multifunction Output for the signals f_{RN} , Φ_V , Φ_{VN} and port 1.
13	15	MFO2	<p>Multifunction I/O-Pin for the output signals f_{VN}, Φ_{RN} and the input signal I_{REF}.</p> <ul style="list-style-type: none"> - The signals Φ_R and Φ_V are the digital output signals of the phase and frequency detector for use in external active current sources (see phase detector output waveforms). - The signals f_{RN} and f_{VN} are the scaled down signals of the reference frequency and VCO-frequency. The L-time corresponds to $1/f_{Ri}$ and $1/f_{Vi}$ respectively. - In the port function the port 1 output signal is assigned to the information of the status program. The output switches with the rising edge of the EN-signal. The standby mode does not affect the port function. - In the internal charge pump mode the input signal I_{REF} determines the value of the PD-output current. <p>Reference current for charge pump:</p> $I_{REF} = (V_{DD} - V_{REF})/R_1$ <p style="margin-left: 2em;">$= 100 \mu A$ (tolerance of 20% or less is recommended)</p> <p>R_1: see application circuit</p> <p>V_{REF}: see AC/DC characteristics</p>

1.4 Functional Block Diagram

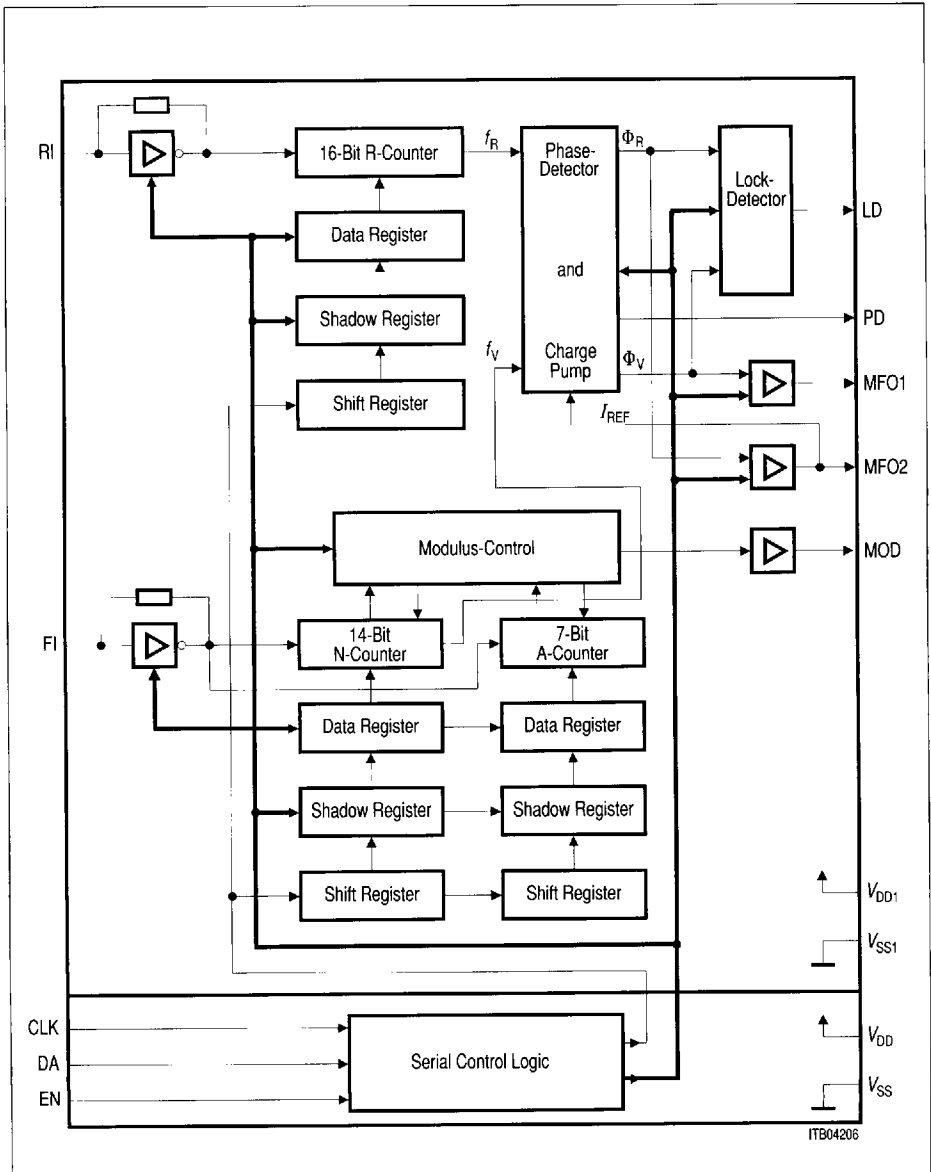

Figure 2

Circuit Description**2 Circuit Description****General Description**

The circuit consists of a reference-, a- and n-counter, a dual modulus control logic, a phase detector with charge pump output and a serial control logic. The setting of the operating mode and the selection of the counter ratios is done serially at the ports CLK, DA and EN.

The operating modes allow the selection of single or dual operation, asynchronous or synchronous data acquisition, 4 different anti-backlash-impulse times, 8 different PD-output current modes, polarity setting of the PD-output signal, adjustment of the trigger-edge of the MOD-output signal, 2 standby modes and the control of the multifunction outputs MFO1 and MFO2.

The reference frequency is applied at the RI-input and scaled down by the r-counter. It's maximum value is 100 MHz. The VCO-frequency is applied at the FI-input and scaled down by the n- or n/a-counter according to single or dual mode operation. The maximum value at FI is 220 MHz at single-, and 65 MHz at dual mode operation.

The phase and frequency sensitive phase detector produces an output signal with adjustable anti-backlash impulses in order to prevent a dead zone for very small phase deviations. Phase differences of less than 100 ps can be resolved. In general the shortest anti-backlash pulse gives the best system performance.

Programming

Programming of the IC is done by a serial data control. The contents of the message are assigned to the functional units according to the address. **Single or dual mode operation as well as asynchronous or synchronous data acquisition is set by status 2 and should therefore precede the programming of the counters.**

Data Acquisition

The PMB 2306T offers the possibility of synchronous data acquisition to avoid error signals at the phase detector due to non-corresponding dividing factors in the counters produced by asynchronous loading.

Synchronous programming guarantees control during changes of frequency or channel. That means that the state of the phase detector or the phase difference is kept maintained, and in case of "lock in", the control process starts with the phase difference "zero".

Circuit Description

This is done as follows:

1. Setting of synchronous data acquisition by status 2.
2. Programming of the r-counter, status 1 (optional)-data is being loaded into shadow registers.
3. Programming of the n- or n/a-counter-data is being loaded into shadow registers, the EN-signal starts the synchronous loading procedure.
4. Synchronous programming – which means data transfer of all data from the shadow registers to the data registers – takes place at that point in time when the respective counter reaches "zero + 1", the maximum repetition rate for channel change is therefore $f_{Fi} \cdot N$.
5. Transfer of status 1 information into the corresponding data register is tied to the n-counter loading, but follows the loading of the n-data register in the distance of one n-counter dividing ratio, this guarantees that for example a new PD-current value becomes valid at the same time when the counters are loaded with the new data.

Synchronous avoids additional phase error caused by programming. Synchronous data acquisition is of especial advantage, when large steps in frequency are to be made in a short time. For this purpose a high reference frequency can be programmed in order to achieve rapid – "rough" – transient response. This method increases the fundamental frequency nearly by the square root of the reference frequency relation. When rough lock is achieved, another synchronous data transfer is needed to switch back to the original channel spacing. A "fine" lock in will finish the total step response. It may not be necessary to change reference frequency, but it make sense to perform synchronous data acquisition in any case. Especially for GSM, PCN, DECT, DAMPS, JDC, PHP systems the synchronous mode should be used to get best performance of the PMB 2306T.

Standby Condition

The PMB 2306T has two standby modes (standby 1, 2) to reduce the current consumption.

Standby 1 switches off the whole circuit, the current consumption is reduced below 1 μ A.

Standby 2 switches off the counters, the charge pump and the outputs, only the preamplifiers stay active.

The standby modes do not affect the port output signal. For the influence on the other output signals **see standby table**.

Note: f_{RN} , f_{VN} , F_{RN} and Φ_{VN} are the inverted signals of f_R , f_V , Φ_R and Φ_V .

Circuit Description

Programming Tables

Status Bits		Multifunction Outputs		
Mode 2	Mode 1	MFO 1	MFO 2	Remarks
0	0	f_{RN}	f_{VN}	test mode
0	1	Φ_V	Φ_{RN}	external charge pump mode 1
1	0	Φ_{VN}	Φ_{RN}	external charge pump mode 2
1	1	Port 1	I_{REF}	internal charge pump mode

Status Bits			PD-Current Mode
PD-Current 3	PD-Current 2	PD-Current 1	
0	0	0	0.175
0	0	1	0.25
0	1	0	0.35
0	1	1	0.5
1	0	0	0.7
1	0	1	1
1	1	0	1.4
1	1	1	2

Programming Tables (cont'd)

Status Bits			
Anti-backlash Pulse Width 2	Anti-backlash Pulse Width 1	t_w (typ.) [ns]	Application
0	0	1.3 ¹⁾	$V_{DD} = 5\text{ V}$
0	1	5	
1	0	10	not recommended
1	1	13 ²⁾	any application where continuous lock detect required

¹⁾ In general the shortest anti-backlash pulse gives the best system performance.

²⁾ No ABL (Anti-backlash-Pulse) gating performed. This means, that at the LD output the anti-backlash pulse will appear. In the other cases the anti-backlash pulse will be suppressed at the LD output.

Circuit Description

Status Bits		Preamplifier Function Mode
Single/ Dual Mode	Preamplifier Select	
0	0	FI-input frequency, single HF-mode
0	1	FI-input frequency, single LF-mode
1	0	FI-input frequency, dual mode, FI-trigger edge LH, MOD A
1	1	FI-input frequency, dual mode, FI-trigger edge HL, MOD B

Standby Table

Status	Output Pins					
	MFO 1		MFO 2	LD	PD	MOD
	Φ_V	Φ_{VN}				
Standby 1	low	high	high	resistive	tristate	low
Standby 2	low	high	high	resistive	tristate	low

Serial Control Data Format (n-, n/a-counter)

Dual Mode

Single Mode

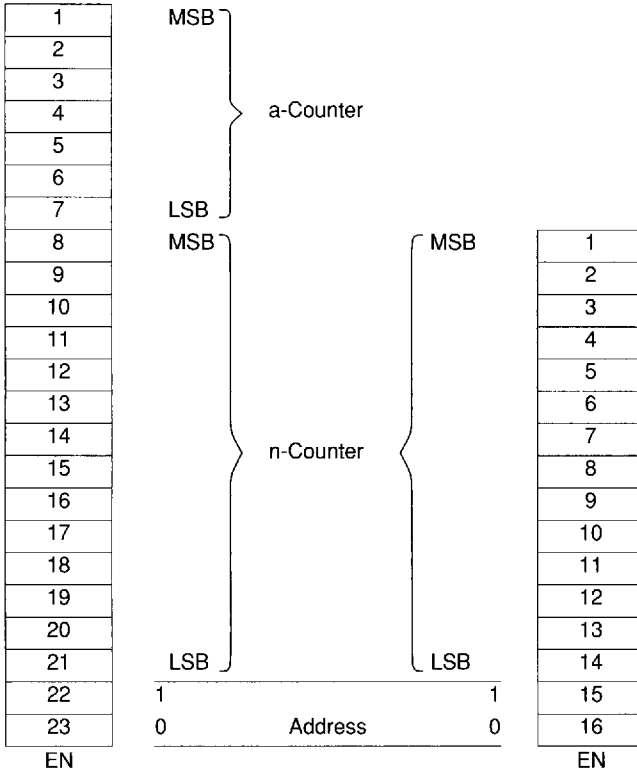

Serial Control Data Format (r-counter)

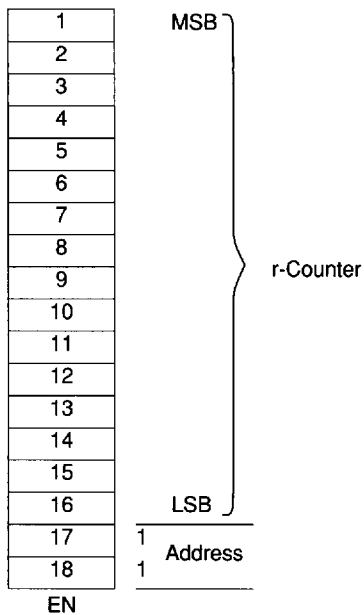

Circuit Description

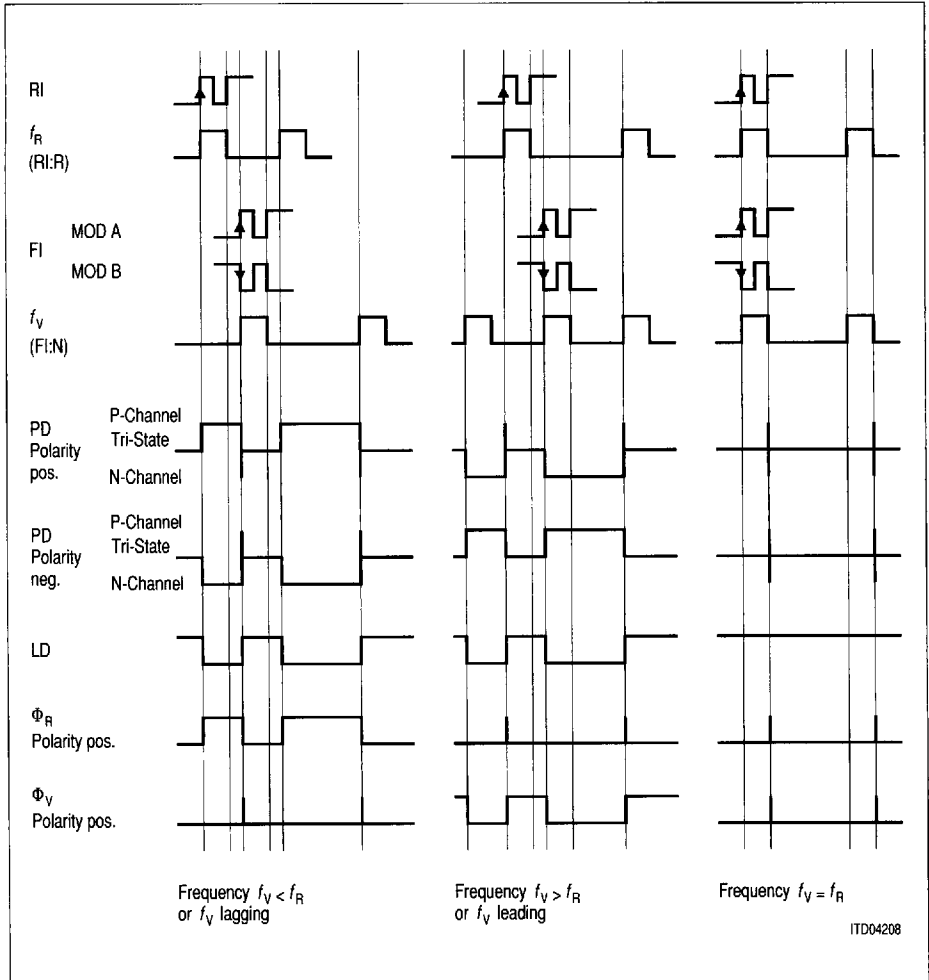

Figure 3
Phase Detector Output Waveforms

Electrical Characteristics

3 Electrical Characteristics

3.1 Absolute Maximum Ratings

$T_A = -40$ to 85 °C

Parameter	Symbol	Limit Values		Unit	Remarks
		min.	max.		
Supply voltage	V_{DD}	- 0.3	6	V	
Input voltage	V_I	- 0.3	$V_{DD} + 0.3$	V	
Output voltage	V_O	GND	V_{DD}	V	
Power dissipation per output	P_Q		10	mW	
Total power dissipation	P_{tot}		300	mW	
Ambient temperature	T_A	- 40	85	°C	in operation
Storage temperature	T_{stg}	- 50	125	°C	

Note: Stresses above those listed here may cause permanent damage to the device. Exposure to absolute maximum rating conditions for extended periods may affect device reliability.

Operating Range

Supply voltage	V_{DD}	3.0	5.5	V	
Input frequency dual mode	f_{FI}	0.1	65	MHz	$V_{DD} = 4.5 \dots 5.5$ V
Input frequency single HF-mode	f_{FI}	0.1	220	MHz	$V_{DD} = 4.5 \dots 5.5$ V
Input frequency single LF-mode	f_{FI}	0.1	90	MHz	$V_{DD} = 4.5 \dots 5.5$ V
Input reference frequency	f_{RI}		100	MHz	$V_{DD} = 4.5 \dots 5.5$ V
Input frequency dual mode	f_{FI}	0.1	30	MHz	$V_{DD} = 3.3$ V
Input frequency single HF-mode	f_{FI}	0.1	120	MHz	$V_{DD} = 3.3$ V
Input frequency single LF-mode	f_{FI}	0.1	35	MHz	$V_{DD} = 3.3$ V
Input reference frequency	f_{RI}		22	MHz	$V_{DD} = 3.3$ V
PD-output current	I_{PD}		4	mA	
PD-output voltage	V_{PD}	0.5	$V_{DD} - 0.5$	V	$V_{DD} = 4.5 - 5.5$ V
PD-output voltage	V_{PD}	0.5	$V_{DD} - 0.5$	V	$V_{DD} = 3.3$ V
Ambient temperature	T_A	- 40	85	°C	

Note: In the operating range the functions given in the circuit description are fulfilled.

All pins are protected against ESD. Unused inputs without pullup resistors must be connected to either V_{DD} or V_{SS} .

Electrical Characteristics

3.2 Typical Supply Current I_{DD}

Parameter	Symbol	Limit Values			Unit	Test Condition
		min.	typ.	max.		
Supply voltage	V_{DD}	3.3	5	5.5	V	
Supply current						
Single mode HF	I_{DD}	1.63	2.6	2.94	mA	$f_{FI} = 50 \text{ MHz}, V_{FI} = 150 \text{ mVrms}$
Dual mode	I_{DD}	1.76	2.80	3.17	mA	$f_{FI} = 10 \text{ MHz}, V_{FI} = 150 \text{ mVrms}$
Standby 2	I_{DD}	0.11	0.62	0.75	mA	$I_{PD} = 0.25 \text{ mA}, I_{ref} = 100 \mu\text{A}$
Standby 1	I_{DD}			1	μA	

3.3 AC/DC Characteristics

Parameter	Symbol	Limit Values			Unit	Test Condition
		min.	typ.	max.		

Input Signals DA, CLK, EN (with internal pull-up resistors)

H-input voltage	V_{IH}	$0.7 V_{DD}$		V_{DD}	V	
L-input voltage	V_{IL}	0		$0.3 V_{DD}$	V	
Input capacity	C_i			5	pF	
H-input current	I_H			10	μA	$V_i = V_{DD} = 5.5 \text{ V}$
L-input current	I_L	-300			μA	$V_i = \text{GND}$

Further information about timing see at **page 24**

Input Signal RI

Input voltage	V_i	100			mVrms	$f = 4 \dots 100 \text{ MHz}, V_{DD} = 4.5 \text{ V}$
Input voltage	V_i	100			mVrms	$f = 4 \dots 22 \text{ MHz}, V_{DD} = 3.3 \text{ V}$
Slew rate		2.5			V/ μs	$V_{DD} = 3.3 \dots 5.5 \text{ V}$
Input capacity	C_i			3	pF	
H-input current	I_H			30	μA	$V_i = V_{DD} = 5.5 \text{ V}$
L-input current	I_L	-30			μA	$V_i = \text{GND}$

Input Signal FI (dual mode)

Input voltage	V_i	180			mVrms	$f = 4 \dots 65 \text{ MHz}, V_{DD} = 4.5 \text{ V}$
Input voltage	V_i	180			mVrms	$f = 4 \dots 30 \text{ MHz}, V_{DD} = 3.3 \text{ V}$
Input voltage	V_i	50			mVrms	$f = 10 \dots 30 \text{ MHz}, V_{DD} = 3.3 \text{ V}$
Slew rate		4			V/ μs	$V_{DD} = 3.3 \dots 5.5 \text{ V}$
Input capacity	C_i			3	pF	
H-input current	I_H			30	μA	$V_i = V_{DD} = 5.5 \text{ V}$
L-input current	I_L	-30			μA	$V_i = \text{GND}$

Electrical Characteristics

3.3 AC/DC Characteristics (cont'd)

Parameter	Symbol	Limit Values			Unit	Test Condition
		min.	typ.	max.		

Input Signal FI (single HF-mode)

Input voltage	V_I	200			mVrms	$f = 4 \dots 220 \text{ MHz}, V_{DD} = 4.5 \text{ V}$
Input voltage	V_I	20			mVrms	$f = 4 \dots 120 \text{ MHz}, V_{DD} = 3.3 \text{ V}$
Input voltage	V_I	50			mVrms	$f = 10 \dots 50 \text{ MHz}, V_{DD} = 4.5 \text{ V}$
Slew rate		2.5			V/ μs	$V_{DD} = 3.3 \dots 5.5 \text{ V}$
Input capacity	C_I			3	pF	
H-input current	I_H			30	μA	$V_I = V_{DD} = 5.5 \text{ V}$
L-input current	I_L	-30			μA	$V_I = \text{GND}$

Input Signal FI (single LF-mode)

Input voltage	V_I	100			mVrms	$f = 4 \dots 90 \text{ MHz}, V_{DD} = 4.5 \text{ V}$
Input voltage	V_I	100			mVrms	$f = 4 \dots 35 \text{ MHz}, V_{DD} = 3.3 \text{ V}$
Slew rate		2.5			V/ μs	$V_{DD} = 3.3 \dots 5.5 \text{ V}$
Input capacity	C_I			3	pF	
H-input current	I_H			30	μA	$V_I = V_{DD} = 5.5 \text{ V}$
L-input current	I_L	-30			μA	$V_I = \text{GND}$

Output Current I_{PD}

Current mode						
"0.175 mA"	I_{PROG}	-20 %		+20 %	mA	$V_{DD} = 4.5 \dots 5.5 \text{ V}$ $V_{PD} = V_{DD}/2$ $I_{REF} = 100 \mu\text{A}$
"0.25 mA"	I_{PROG}	-20 %		+20 %	mA	
"0.35 mA"	I_{PROG}	-20 %		+20 %	mA	
"0.5 mA"	I_{PROG}	-20 %		+20 %	mA	
"0.7 mA"	I_{PROG}	-20 %		+20 %	mA	
"1.0 mA"	I_{PROG}	-10 %		+10 %	mA	
"1.4 mA"	I_{PROG}	-10 %		+10 %	mA	
"2.0 mA"	I_{PROG}	-10 %		+10 %	mA	
"Standby"	I_{PD} / I_{PROG}		0.1*	50	nA	$V_{DD} = 5.5 \text{ V}$
* guaranteed by design						

Output Tolerances I_{PD}

$\Delta I_{PD} / I_{PROG}$		-20 %		+3 %	\pm	$V_{PD} = V_{DD}/2, V_{DD} = 3.3 \text{ V}$
$\Delta I_{PD} / I_{PROG}$			$\pm 4\%$			$V_{PD} = 1 \dots 4 \text{ V}, V_{DD} = 5 \text{ V}$

Electrical Characteristics

3.3 AC/DC Characteristics (cont'd)

Parameter	Symbol	Limit Values			Unit	Test Condition
		min.	typ.	max.		

Input Voltage MFO2 (internal charge pump mode)

Reference voltage	V_{REF}	0.9	1.1	1.3	V	$V_{DD} = 4.5 \dots 5.5 \text{ V}$, $I_{REF} = 100 \mu\text{A}$
-------------------	-----------	-----	-----	-----	---	---

Output Signal MFO1 (push pull)

H-output voltage	V_{OH}	$V_{DD} - 1$			V	$V_{DD} = 4.5 \dots 5.5 \text{ V}$, $I_{OH} = 2 \text{ mA}$
L-output voltage	V_{OL}			1	V	$V_{DD} = 4.5 \dots 5.5 \text{ V}$, $I_{OL} = 2 \text{ mA}$
H-output voltage	V_{OH}	$V_{DD} - 1$			V	$V_{DD} = 3.3 \text{ V}$, $I_{OH} = 1.2 \text{ mA}$
L-output voltage	V_{OL}			1	V	$V_{DD} = 3.3 \text{ V}$, $I_{OL} = 1.2 \text{ mA}$
Rise time	t_R		2.5	10	ns	$V_{DD} = 4.5 \dots 5.5 \text{ V}$, $C_1 = 10 \text{ pF}$
Fall time	t_F		2.0	10	ns	$V_{DD} = 4.5 \dots 5.5 \text{ V}$, $C_1 = 10 \text{ pF}$
Rise time	t_R		4.0	10	ns	$V_{DD} = 3.3 \text{ V}$, $C_1 = 10 \text{ pF}$
Fall time	t_F		2.5	10	ns	$V_{DD} = 3.3 \text{ V}$, $C_1 = 10 \text{ pF}$

Output Signal MFO2 (push pull)

H-output voltage	V_{OH}	$V_{DD} - 1$			V	$V_{DD} = 4.5 \dots 5.5 \text{ V}$, $I_{OH} = 2 \text{ mA}$
L-output voltage	V_{OL}			1	V	$V_{DD} = 4.5 \dots 5.5 \text{ V}$, $I_{OL} = 2 \text{ mA}$
H-output voltage	V_{OH}	$V_{DD} - 1$			V	$V_{DD} = 3.3 \text{ V}$, $I_{OH} = 1.2 \text{ mA}$
L-output voltage	V_{OL}			1	V	$V_{DD} = 3.3 \text{ V}$, $I_{OL} = 1.2 \text{ mA}$
Rise time	t_R		2	10	ns	$V_{DD} = 4.5 \dots 5.5 \text{ V}$, $C_1 = 10 \text{ pF}$
Fall time	t_F		2	10	ns	$V_{DD} = 4.5 \dots 5.5 \text{ V}$, $C_1 = 10 \text{ pF}$
Rise time	t_R		3	10	ns	$V_{DD} = 3.3 \text{ V}$, $C_1 = 10 \text{ pF}$
Fall time	t_F		3	10	ns	$V_{DD} = 3.3 \text{ V}$, $C_1 = 10 \text{ pF}$

Output Signal LD (n-channel open drain)

L-output voltage	V_{OL}			0.4	V	$V_{DD} = 4.5 \dots 5.5 \text{ V}$, $I_{OL} = 0.5 \text{ mA}$
L-output voltage	V_{OL}			0.4	V	$V_{DD} = 3.3 \text{ V}$, $I_{OL} = 0.5 \text{ mA}$
Fall time	t_F		3	10	ns	$V_{DD} = 4.5 \dots 5.5 \text{ V}$, $C_1 = 10 \text{ pF}$
Fall time	t_F		4.5	10	ns	$V_{DD} = 3.3 \text{ V}$, $C_1 = 10 \text{ pF}$

Electrical Characteristics

3.3 AC/DC Characteristics (cont'd)

Parameter	Symbol	Limit Values			Unit	Test Condition
		min.	typ.	max.		

Output Signal MOD (push-pull)

H-output voltage	V_{OH}	V_{DD} -0.4			V	$V_{DD} = 4.5 \dots 5.5 \text{ V}$, $I_{OH} = 0.5 \text{ mA}$
L-output voltage	V_{OL}			0.4	V	$V_{DD} = 4.5 \dots 5.5 \text{ V}$, $I_{OL} = 0.5 \text{ mA}$
H-output voltage	V_{OH}	V_{DD} -0.4			V	$V_{DD} = 3.3 \text{ V}$, $I_{OH} = 0.3 \text{ mA}$
L-output voltage	V_{OL}			0.4	V	$V_{DD} = 3.3 \text{ V}$, $I_{OL} = 0.3 \text{ mA}$
Rise time	t_R		1.5	3	ns	$V_{DD} = 4.5 \dots 5.5 \text{ V}$, $C_1 = 5 \text{ pF}$
Fall time	t_F		1.3	3	ns	$V_{DD} = 4.5 \dots 5.5 \text{ V}$, $C_1 = 5 \text{ pF}$
Propagation delay time H-L to FI	t_{DQHL}		8	12	ns	$V_{DD} = 4.5 \dots 5.5 \text{ V}$, $C_1 = 5 \text{ pF}$
Propagation delay time L-H to FI	t_{DQLH}		8	12	ns	$V_{DD} = 4.5 \dots 5.5 \text{ V}$, $C_1 = 5 \text{ pF}$
Rise time	t_R		2.8	4	ns	$V_{DD} = 3.3 \text{ V}$, $C_1 = 5 \text{ pF}$
Fall time	t_F		1.6	4	ns	$V_{DD} = 3.3 \text{ V}$, $C_1 = 5 \text{ pF}$
Propagation delay time H-L to FI	t_{DQHL}		12		ns	$V_{DD} = 3.3 \text{ V}$, $C_1 = 5 \text{ pF}$
Propagation delay time L-H to FI	t_{DQLH}		12		ns	$V_{DD} = 3.3 \text{ V}$, $C_1 = 5 \text{ pF}$

Further information about timing see at **page 23**.

Note: The listed characteristics are ensured over the operating range of the integrated circuit. Typical characteristics specify mean values expected over the production spread. If not otherwise specified, typical characteristics apply at $T_A = 25^\circ\text{C}$ and the given supply voltage.

Electrical Characteristics

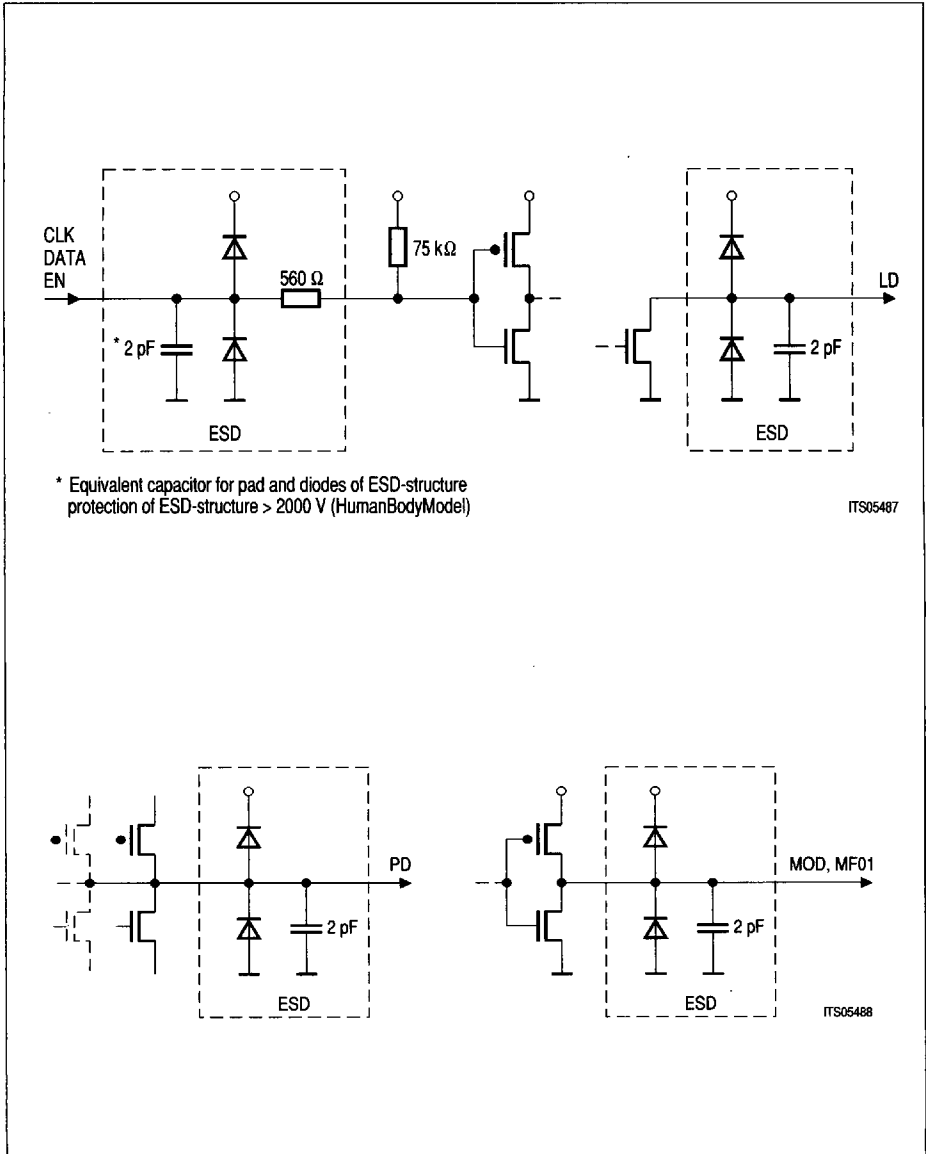

* Equivalent capacitor for pad and diodes of ESD-structure protection of ESD-structure > 2000 V (HumanBodyModel)

ITS05487

ITS05488

Figure 4
Equivalent I/O Schematics

Electrical Characteristics

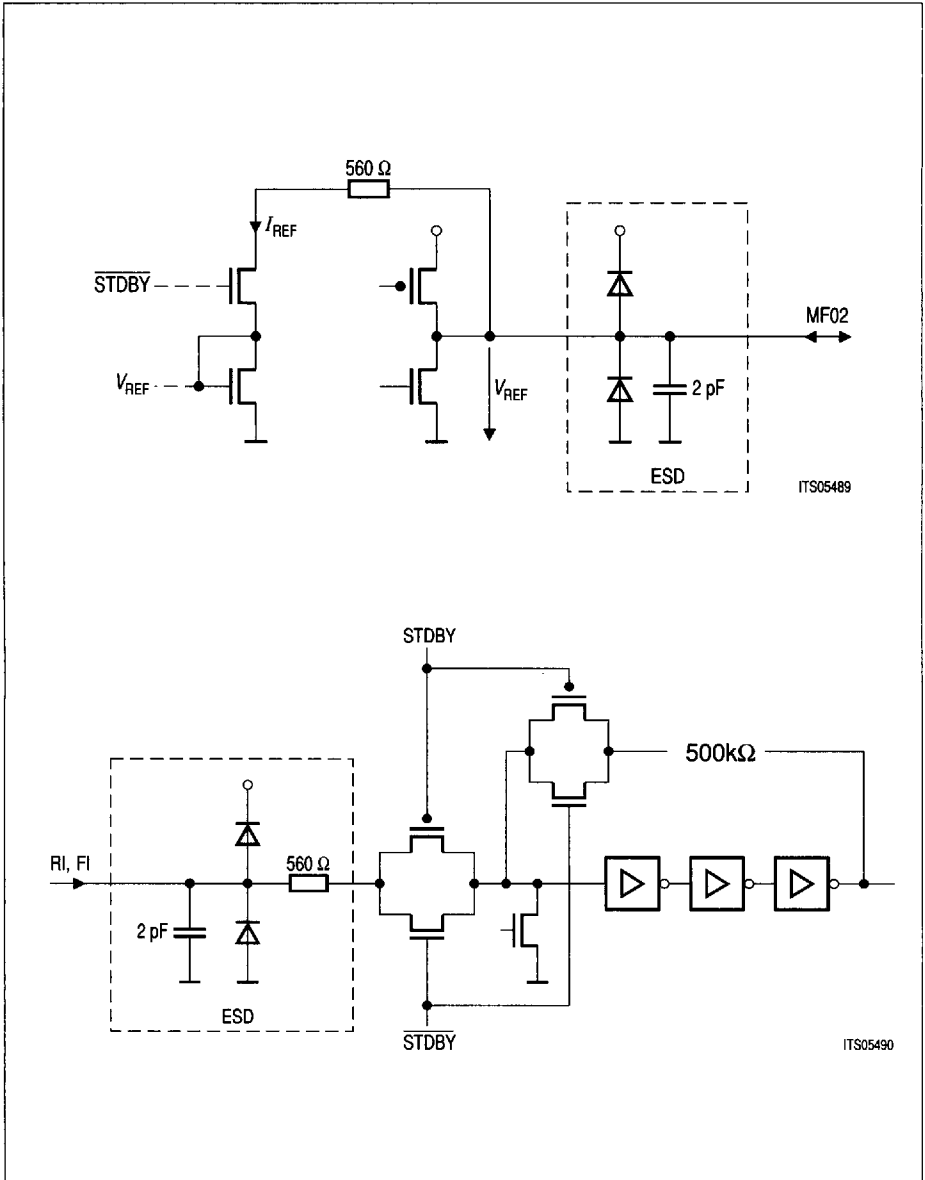

Figure 5
Equivalent I/O Schematics (cont'd)

Electrical Characteristics

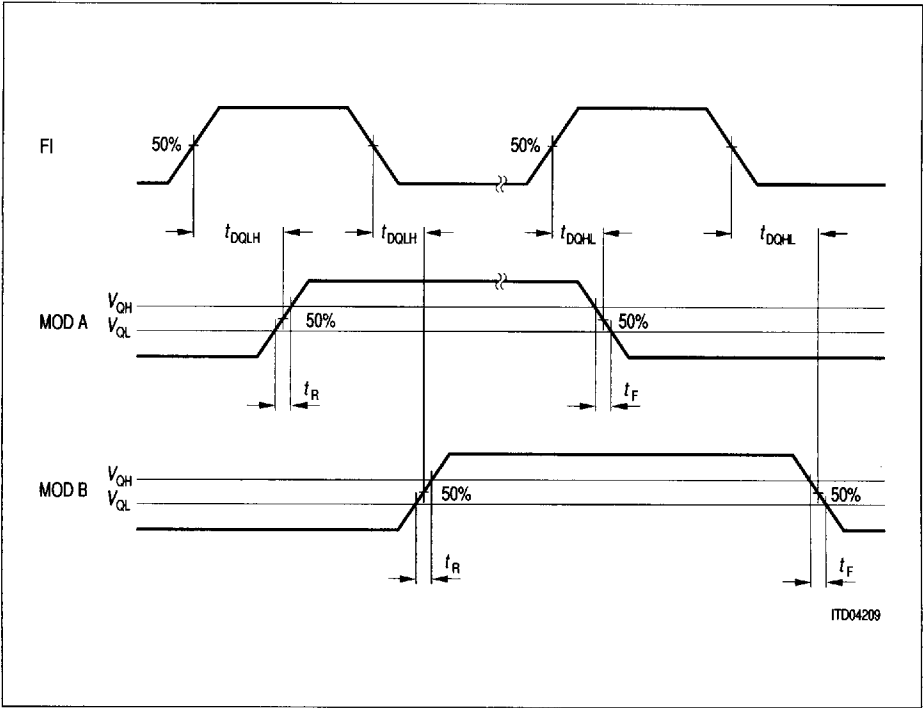

Figure 6
Modulus Control Output Timing

Electrical Characteristics

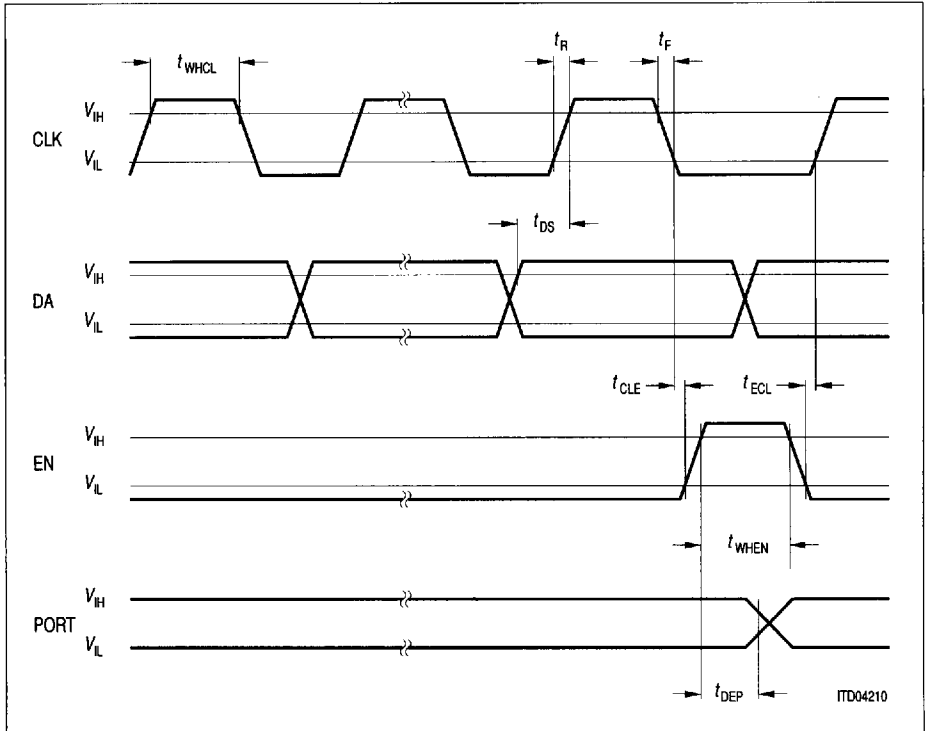

Figure 7
Serial Control Data Input Timing

Parameter	Symbol	Limit Values		Unit	Test Condition
		min.	max.		
Clock frequency	f_{CL}		12	MHz	$V_{DD} = 3.3 V$
H-pulsewidth (CL)	t_{WHCL}	40		ns	
Data setup	t_{DS}	20		ns	
Setup time clock-enable	t_{CLE}	20		ns	
Setup time enable-clock	t_{ECL}	20		ns	
H-pulsewidth (enable)	t_{WHEN}	40		ns	
Rise, fall time	t_R, t_F		10	μs	
Propagation delay time EN-PORT	t_{DEP}		1	μs	

Electrical Characteristics

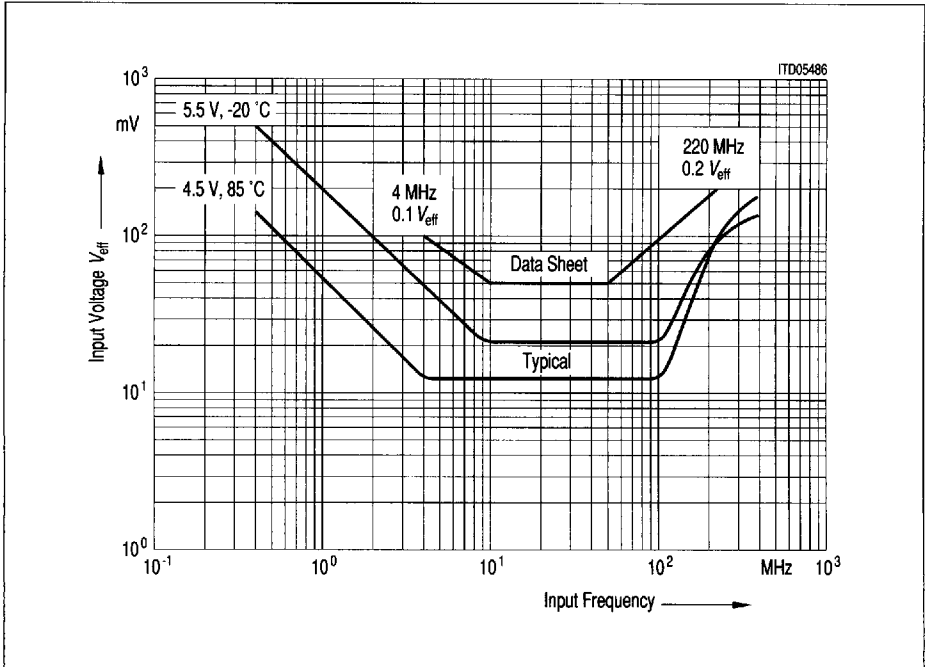

Figure 8
Input Sensitivity Signal FI (single HF-mode)

Electrical Characteristics

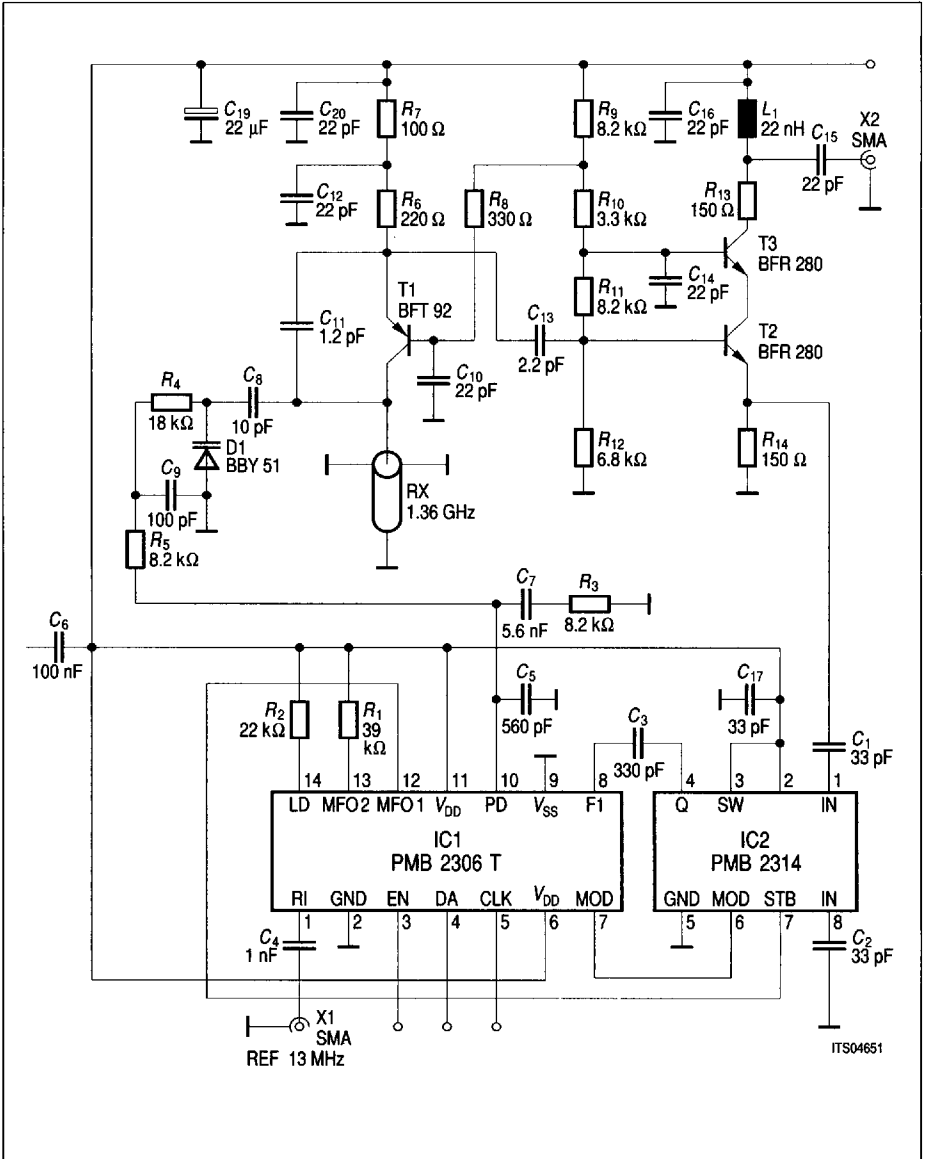

Figure 9
GSM Application Circuit

Electrical Characteristics

List of Components

Item	Quantity Reference		Part	
1	1 R_7	100 Ω	SMD/0805 B54102-A1101-K60	S+M
2	2 R_{13}, R_{14}	150 Ω	SMD/0805 B54102-A1151-J60	S+M
3	1 R_6	220 Ω	SMD/0805 B54102-A1221-J60	S+M
4	1 R_8	330 Ω	SMD/0805 B54102-A1331-J60	S+M
5	1 R_{10}	3.3 k Ω	SMD/0805 B54102-A1332-J60	S+M
6	1 R_{12}	6.8 k Ω	SMD/0805 B54102-A1682-J60	S+M
7	4 R_9, R_3, R_5, R_{11}	8.2 k Ω	SMD/0805 B54102-A1822-J60	S+M
8	1 R_4	18 k Ω	SMD/0805 B54102-A1183-J60	S+M
9	1 R_2	22 k Ω	SMD/0805 B54102-A1223-J60	S+M
10	1 R_2	39 k Ω	SMD/0805 B54102-A1393-J60	S+M
11	1 L_1	22 nH	SIMID 01 B82412-A3220-M	S+M
12	1 C_{11}	1.2 pF	COG/0805 B37940-K5010-C262	S+M
13	1 C_{13}	2.2 pF	COG/0805 B37940-K5020-C262	S+M
14	1 C_8	10 pF	COG/0805 B37940-K5100-J62	S+M
15	6 $C_{20}, C_{10}, C_{12}, C_{14}, C_{15}, C_{16}$	22 pF	COG/0805 B37940-K5220-J62	S+M
16	3 C_{17}, C_1, C_2	33 pF	COG/0805 B37940-K5330-J62	S+M
17	1 C_9	100 pF	COG/0805 B37940-K5101-J62	S+M
18	1 C_3	330 pF	COG/0805 B37940-K5331-J62	S+M
19	1 C_5	560 pF	COG/0805 B37940-K5561-J62	S+M
20	1 C_7	5.6 nF	COG/1210 B37949-K5562-J62	S+M
21	1 C_6	100 nF	X7R/1210 B37950-K5104-K62	S+M
22	1 C_{19}	22 μ F	B45196-E3226-+409	S+M
23	1 D1	BBY 51	Q62702-B631	SIEMENS
24	2 T3, T2	BFR 280	Q62702-F1298	SIEMENS
25	1 T1	BFT 92	Q62702-F1062	SIEMENS
26	1 C_4	1,0 nF	COG/1210 B37949-K5102-J62	S+M
27	2 X2, X1	SMA	Connector	
28	1 RX	1.3 GHz	B69610-G1307-A412	S+M
29	1 IC1	PMB 2306T P-DSO-14	Q67100-H6423	SIEMENS
		PMB 2306T P-DSO-14	Q67106-H6423(T+R)	SIEMENS
30	1 IC2	PMB 2314 P-DSO-8	Q67000-A6121	SIEMENS
		PMB 2314 P-DSO-8	Q67006-A6121(T+R)	SIEMENS

Electrical Characteristics

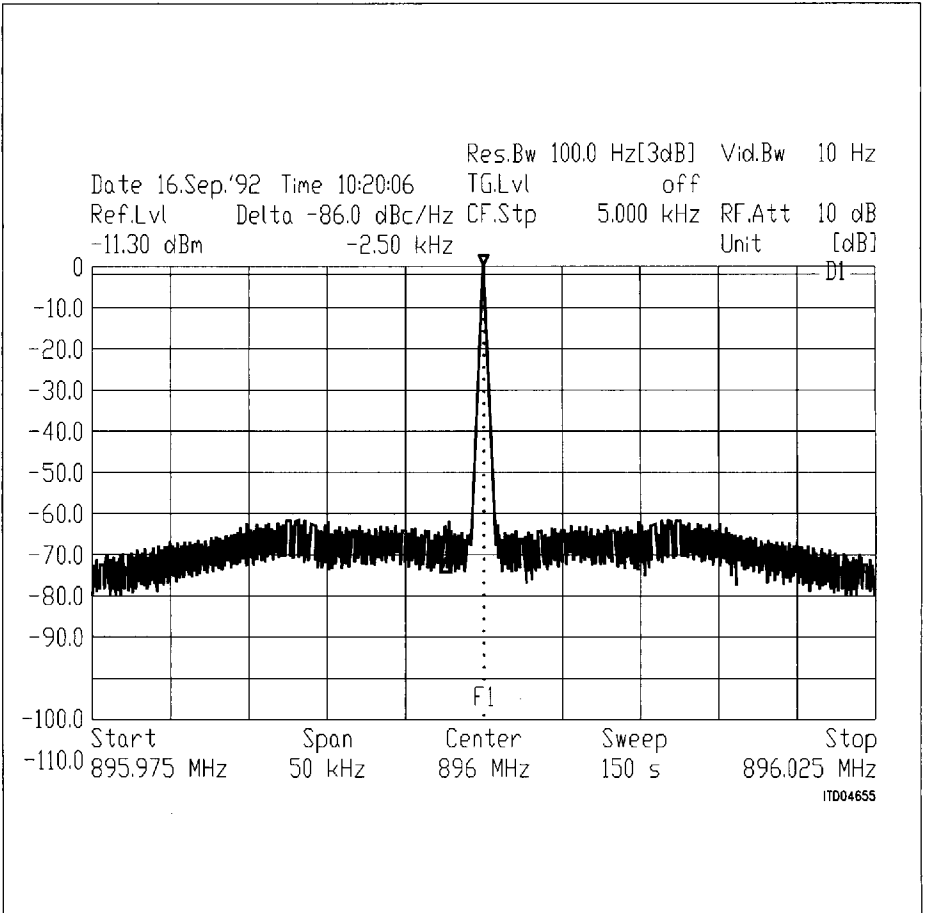

Figure 10
Phase Noise Close to the Carrier

Electrical Characteristics

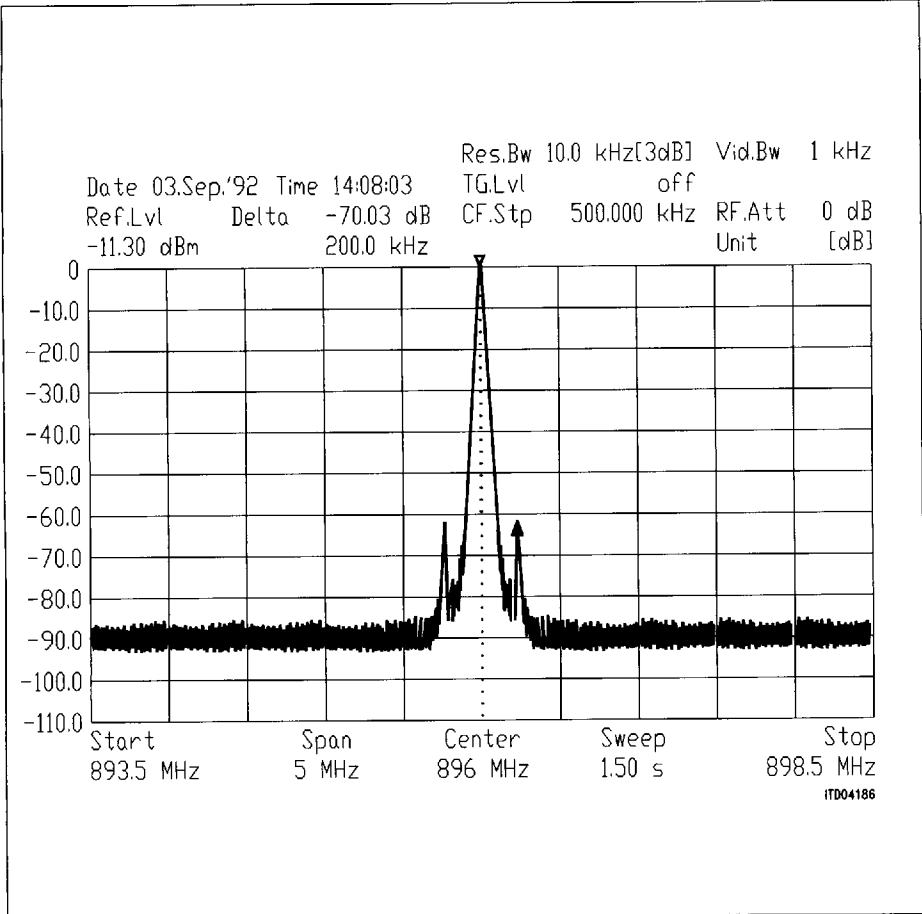

Figure 11
Spectrum at Lower End of GSM TX Board (Mobile)

Electrical Characteristics

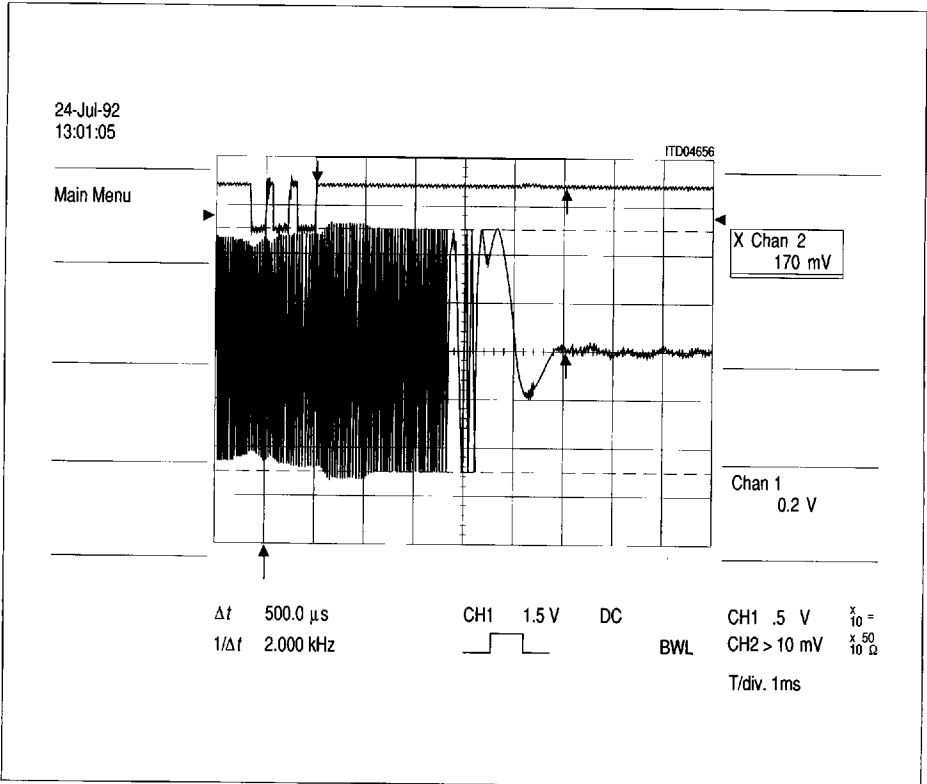

Figure 12
Lock-In Time for GSM Application

Electrical Characteristics

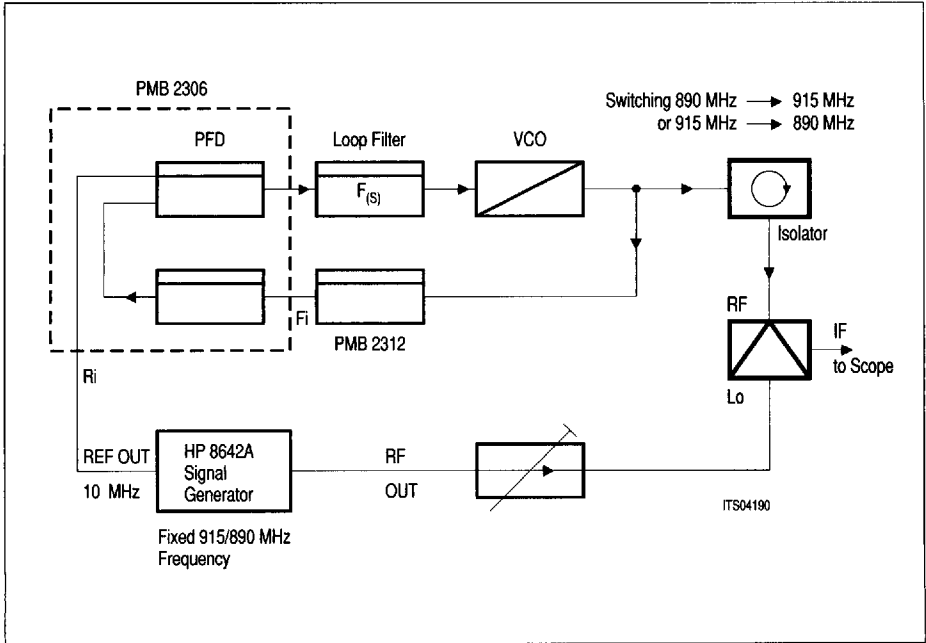
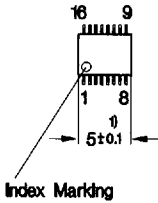
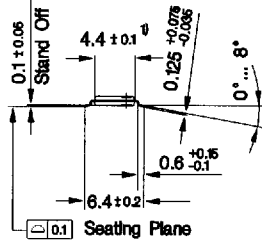
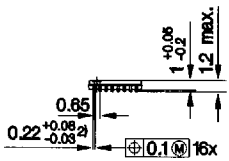

Figure 13
Measurement Set-Up for Lock-In Time

4 Package Outlines

4.1 Plastic-Package, P-TSSOP-16 (SMD)

P-TSSOP-16
(Plastic Thin Shrink Small Outline Package)



- 1) Does not include plastic or metal protrusion of 0.15 max. per side
- 2) Does not include dambar protrusion of 0.08 max. per side

GPS05864

Sorts of Packing

Package outlines for tubes, trays etc. are contained in our Data Book "Package Information".

SMD = Surface Mounted Device

Dimensions in mm

4.2 Plastic-Package, P-DSO-14-1(SMD)

P-DSO-14-1

(Plastic Dual Small Outline Package)

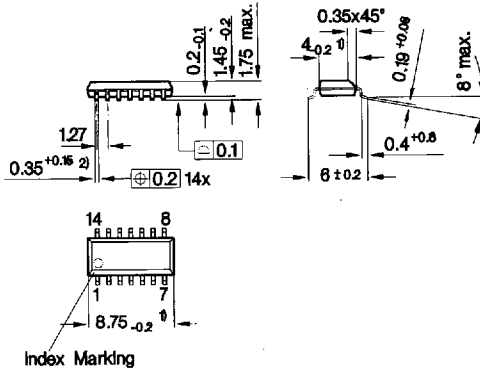

- 1) Does not include plastic or metal protrusion of 0.15 max. per side
- 2) Does not include dambar protrusion

GPS05093

B115-H6917-G2-X-7600

Sorts of Packing

Package outlines for tubes, trays etc. are contained in our Data Book "Package Information".

SMD = Surface Mounted Device

Dimensions in mm