



**PI90LV031A
PI90LV027A
PI90LV017A**

**3V LVDS High-Speed
Differential Line Drivers**

Features

- Signaling Rates >400Mbps (200 MHz)
- Single 3.3V Power Supply Design
- ±350mV Differential Swing
- Maximum Differential Skew of 0.4ns
- Maximum Propagation Delay of 2.0ns
- Maximum Power Dissipation: 25mW @ 200 MHz/driver
- Low Voltage TTL (LVTTTL) Inputs
- Industrial Temperature Operating Range: -40°C to 85°C
- Package Options Available: SOIC, TSSOP, MSOP
- Meets or Exceeds IEEE 1596.3 SCILVDS Standard
- Meets or Exceeds ANSI/TIA/EIA-644 LVDS Standard

Description

The PI90LV031A, PI90LV027A, and PI90LV017A are differential line drivers that use low-voltage differential signaling (LVDS) to support data rates in excess of 400 Mbps. These products are designed for applications requiring high-speed, low-power consumption and low noise generation.

A low voltage TTL/CMOS input level is translated by the device into a low-voltage (350mV) differential output signal. Exclusive to the PI90LV031A quad driver is a power-down mode that Tri-states the outputs and places the device in a low-power idle state (13mW typical).

Applications

Applications include point-to-point and multidrop baseband data transmission over controlled impedance media of approximately 100 Ohms. The transmission media can be printed circuit board traces, backplanes, or cables.

The PI90LV031A, PI90LV027A, PI90LV017A and companion line receivers (PI90LV032A, PI90LV028A, and PI90LV018A) provide new alternatives to RS-232, PECL, and ECL devices for high-speed, point-to-point interface applications.

PI90LV031A

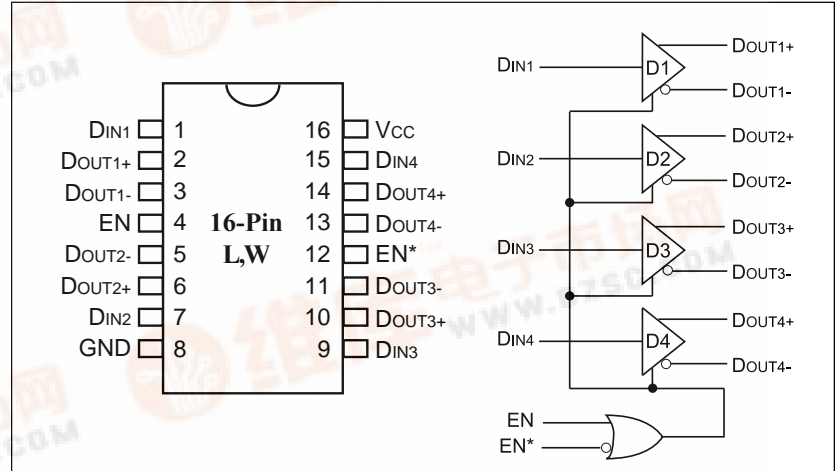

PI90LV027A

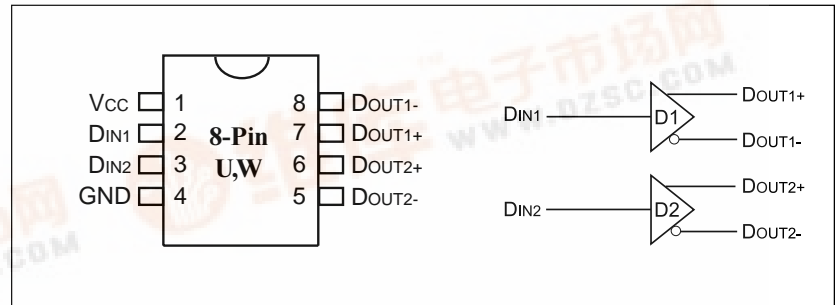

PI90LV017A

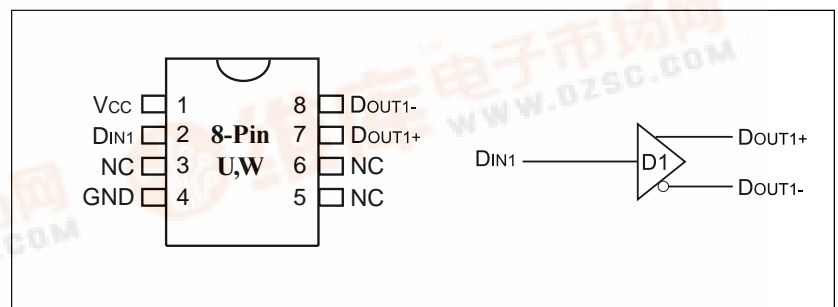



PI90LV031A/PI90LV027A/PI90LV017A
3V LVDS High-Speed Differential Line Drivers

Function Tables

PI90LV031A

Enables		Input	Outputs	
EN	EN*	D _{IN}	D _{OUT+}	D _{OUT-}
H	X	H	H	L
H	X	L	L	H
X	L	H	H	L
X	L	L	L	H
L	H	X	Z	Z

Pin Descriptions

Name	Description
D _{IN}	TTL/CMOS driver input pins
D _{O+}	Non-inverting driver output pins
D _{O-}	Inverting driver output pins
GND	Ground pin
V _{CC}	Positive power supply pin, +3.3V ±10%

PI90LV027A

Input	Outputs	
D _{IN}	D _{OUT+}	D _{OUT-}
H	H	L
L	L	H

Recommended Operating Conditions

	Min.	Typ.	Max.	Units
Supply Voltage (V _{CC})	+3.0	+3.3	+3.6	V
Operating Free Air Temperature	-40	+25	+85	°C

PI90LV017A

Input	Outputs	
D _{IN}	D _{OUT+}	D _{OUT-}
H	H	L
L	L	H

Absolute Maximum Ratings (see Note 1, Page 4)

Supply Voltage (V _{CC})	-0.3V to +4.0V
Input Voltage (D _{IN})	-0.3V to (V _{CC} +0.3V)
Enable Input Voltage (EN, EN*)	-0.3V to (V _{CC} +0.3V)
Output Voltage (D _{OUT+} , D _{OUT-})	-0.3V to +3.9V
Short Circuit Duration (D _{OUT+} , D _{OUT-})	Continuous
S Package	750mW
Derate S Package	8.5mW/°C above +25°C
Storage Temperature Range	-65°C to +150°C
Lead Temperature Range Soldering (4s)	+260°C
Maximum Junction Temperature	+150°C
ESD Rating	≥6kV

Note:

Stresses greater than those listed under Absolute Maximum Ratings may cause permanent damage to the device. This is a stress rating only and functional operation of the device at these or any other conditions above those indicated in the operational sections of this specification is not implied. Exposure to absolute maximum rating conditions for extended periods may affect reliability.



PI90LV031A/PI90LV027A/PI90LV017A
3V LVDS High-Speed Differential Line Drivers

Electrical Characteristics

Over supply voltage and operating temperature ranges, unless otherwise specified. (Notes 2,3,4)

Symbol	Parameter	Conditions	Pin	Min.	Typ.	Max.	Units
V _{OD1}	Differential Output Voltage	R _L = 100Ω (Fig.1)	D _{OUT-} D _{OUT+}	250	350	450	mV
ΔV _{OD1}	Change in Magnitude of V _{OD1} for Complementary Output States				4	35	lmVl
V _{OS}	Offset Voltage			1.125	1.25	1.375	V
ΔV _{OS}	Change in Magnitude of V _{OS} for Complementary Output States				5	25	lmVl
V _{OH}	Output Voltage High				1.38	1.6	V
V _{OL}	Output Voltage Low			0.90	1.03		
V _{IH}	Input Voltage High		D _{IN} EN EN*	2.0		V _{CC}	V
V _{IL}	Input Voltage Low			GND		0.8	
I _{IH}	Input Current			V _{IN} = V _{CC} or 2.5V	-10	±1	+10
I _{IL}	Input Current	V _{IN} = GND or 0.4V	-10	±1	+10		
V _{CL}	Input Clamp Voltage	I _{CL} = -18mA		-1.5	-0.8		V
I _{OS}	Output Short Circuit Current	ENABLED, ⁽¹⁰⁾ D _{IN} = V _{CC} , D _{OUT+} = 0V or D _{IN} = GND, D _{OUT-} = 0V	D _{OUT-} D _{OUT+}		-6.0	-9.0	mA
I _{OSD}	Differential Output Short Circuit Current	ENABLED, V _{OD} = 0V ⁽¹⁰⁾			-6.0	-9.0	
I _{OFF}	Power-off Leakage	V _{OUT} = 0V or 3.6V, V _{CC} = 0V or Open		-20	±1	+20	μA
I _{OZ}	Output Three-State Current	EN = 0.8V and EN* = 2.0V V _{OUT} = 0V or V _{CC}		-10	±1	+10	
I _{CC}	No Load Supply Current Drivers Enabled	D _{IN} = V _{CC} or GND	V _{CC}		5.0	8.0	mA
I _{CCL}	Loaded Supply Current Drivers Enabled	R _L = 100Ω All Channels, D _{IN} = V _{CC} or GND (all inputs)			23	30	
I _{CCZ}	No Load Supply Current Drivers Disabled	D _{IN} = V _{CC} or GND, EN = GND, EN* = V _{CC}			2.6	6.0	



PI90LV031A/PI90LV027A/PI90LV017A
3V LVDS High-Speed Differential Line Drivers

Switching Characteristics

$V_{CC} = +3.3V \pm 10\%$, $T_A = -40^\circ C$ to $+85^\circ C$ (Notes 3,9,11)

Symbol	Parameter	Conditions	Min.	Typ.	Max.	Units
tPHLD	Differential Propagation Delay High to Low	$R_L = 100\Omega$, $C_L = 10pF$ (Figures 2 & 3)	0.8	1.18	2.0	ns
tPLHD	Differential Propagation Delay Low to High		0.8	1.25	2.0	
tsKD1	Differential Pulse Skew tPHLD - tPLHD ⁽⁵⁾		0	0.07	0.4	
tsKD2	Channel-to-Channel Skew ⁽⁶⁾		0	0.1	0.5	
tsKD3	Differential Part-to-Part Skew ⁽⁷⁾		0		1.0	
tsKD4	Differential Part-to-Part Skew ⁽⁸⁾		0		1.2	
tTLH	Rise Time			0.38	1.5	
tTHL	Fall Time			0.40	1.5	
tPHZ	Disable Time High to Z	$R_L = 100\Omega$, $C_L = 10pF$ (Figures 4 & 5)			5	
tPLZ	Disable Time Low to Z				5	
tPZH	Enable Time Z to High				7	
tPZL	Enable Time Z to Low				7	
tMAX	Maximum Operating Frequency ⁽¹³⁾		200	250		MHz

Notes:

1. "Absolute Maximum Ratings" are those values beyond which the safety of the device cannot be guaranteed. They are not meant to imply that the devices should be operated at these limits. The table of "Electrical Characteristics" specifies conditions of device operation.
2. Current into device pins is defined as positive. Current out of device pins is defined as negative. All voltages are referenced to ground except: V_{OD1} and ΔV_{OD1} .
3. All typicals are given for: $V_{CC} = +3.3V$, $T_A = +25^\circ C$.
4. The PI90LV031A/PI90LV027A/PI90LV017A are current mode devices and only functions within datasheet specifications when a resistive load is applied to the driver outputs typical range is (90Ω to 110Ω).
5. tsKD1, |tPHLD - tPLHD| is the magnitude difference in differential propagation delay time between the positive going edge and the negative going edge of the same channel.
6. tsKD2 is the Differential Channel-to-Channel Skew of any event on the same device.
7. tsKD3, Differential Part-to-Part Skew, is defined as the difference between the minimum and maximum specified differential propagation delays. This specification applies to devices at the same V_{CC} and with 5°C of each other within the operating temperature range.
8. tsKD4, Part-to-Part Skew, is the differential Channel-to-Channel skew of any event between devices. This specification applies to devices over recommended operating temperature and voltage ranges, and across process distribution. tsKD4 is defined as |Max - Min| differential propagation delay.
9. Generator waveform for all tests unless otherwise specified: $f = 1$ MHz, $Z_O = 50\Omega$, $t_r \leq 1ns$, and $t_f \leq 1ns$.
10. Output short circuit current (I_{OS}) is specified as magnitude only, minus sign indicates direction only.
11. C_L includes probe and jig capacitance.
12. All input voltages are for one channel unless otherwise specified. Other inputs are set to GND.
13. fMAX generator input conditions: $t_R = t_F < 1ns$, (0% to 100%), 50% duty cycle, 0V to 3V.
 Output Criteria: duty cycle = 45%/55%, $V_{OD} > 250mV$, all channels switching.

Parameter Measurement Information

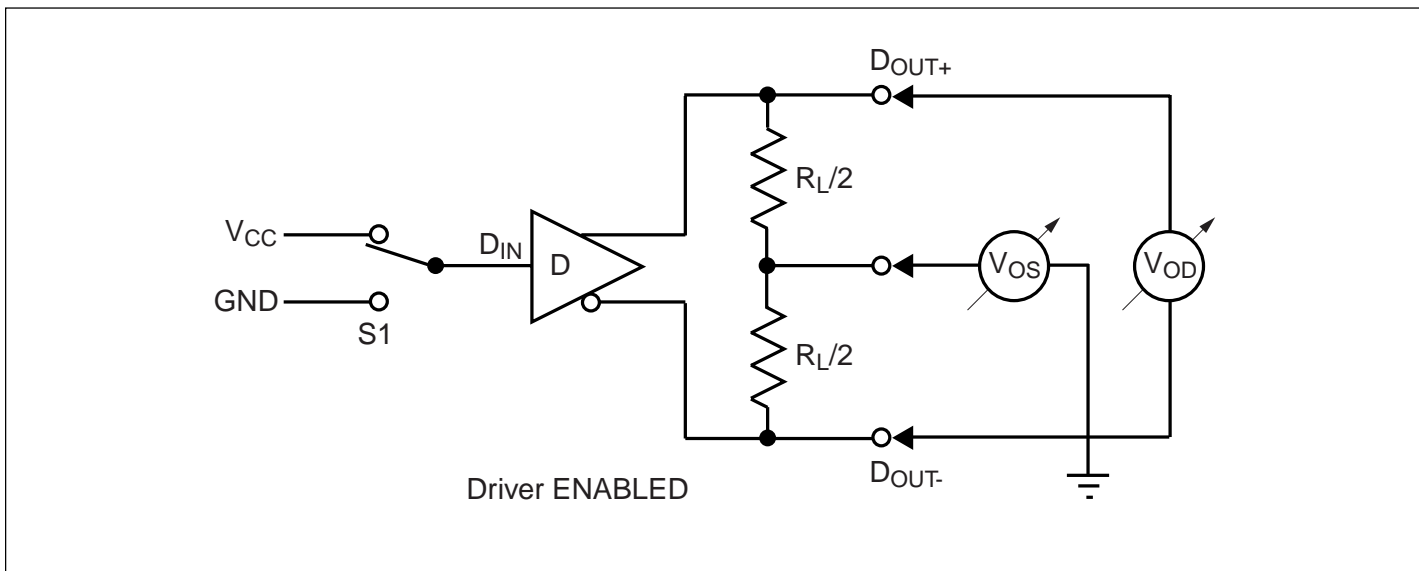

Figure 1. Driver V_{OD} and V_{OS} Test Circuit

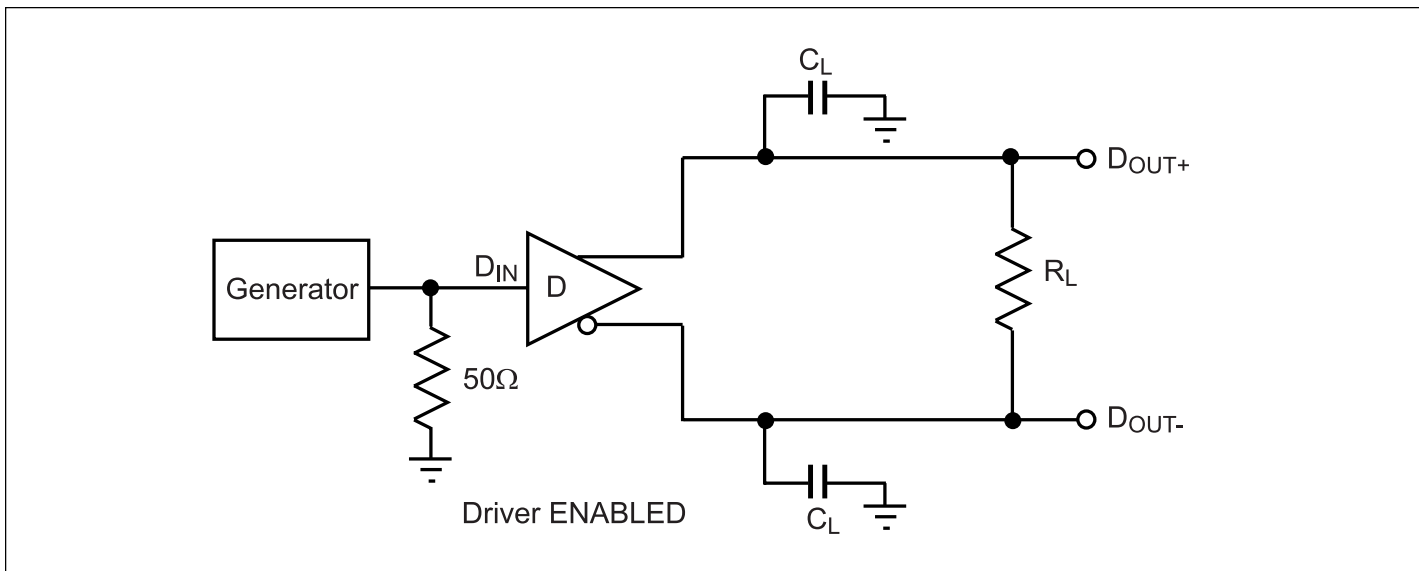

Figure 2. Driver Propagation Delay and Transition Time Test Circuit

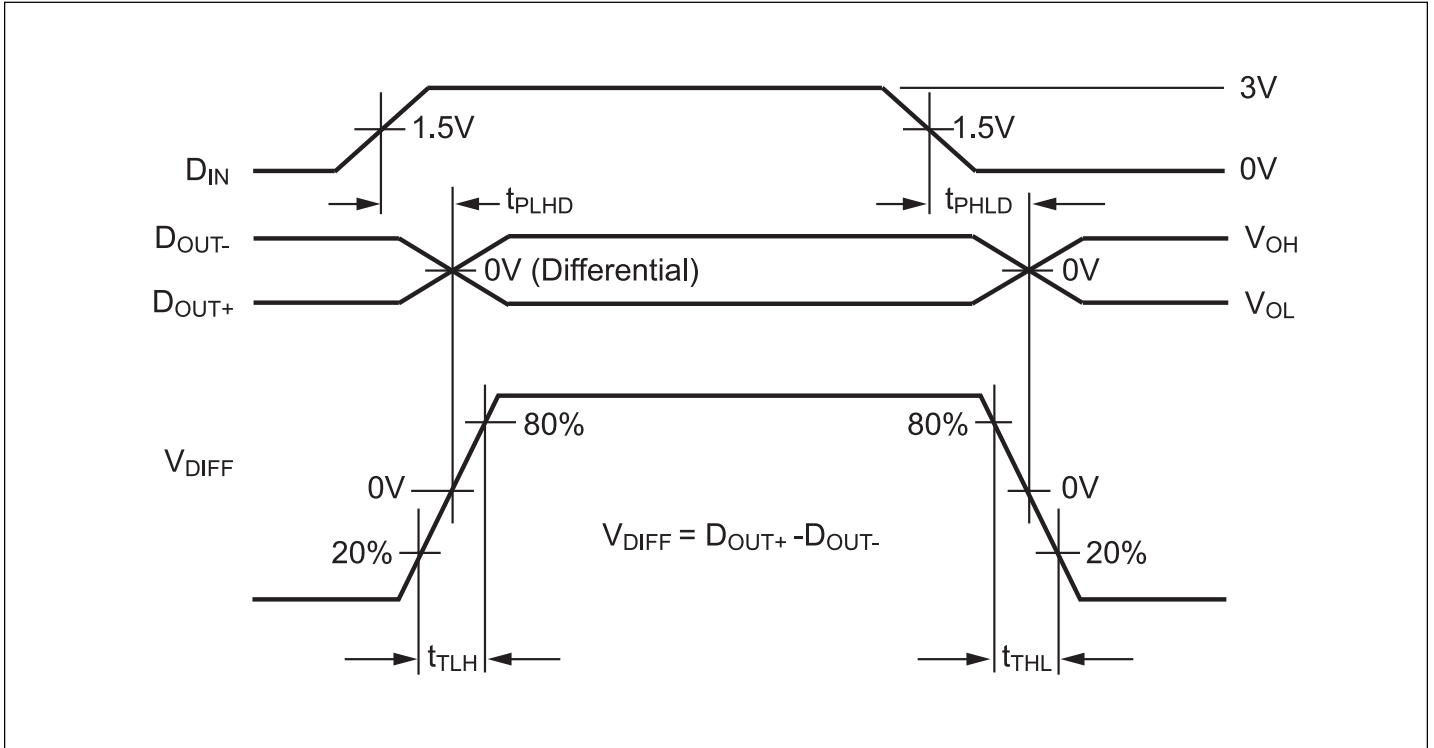

Figure 3. Driver Propagation Delay and Transition Time Waveforms

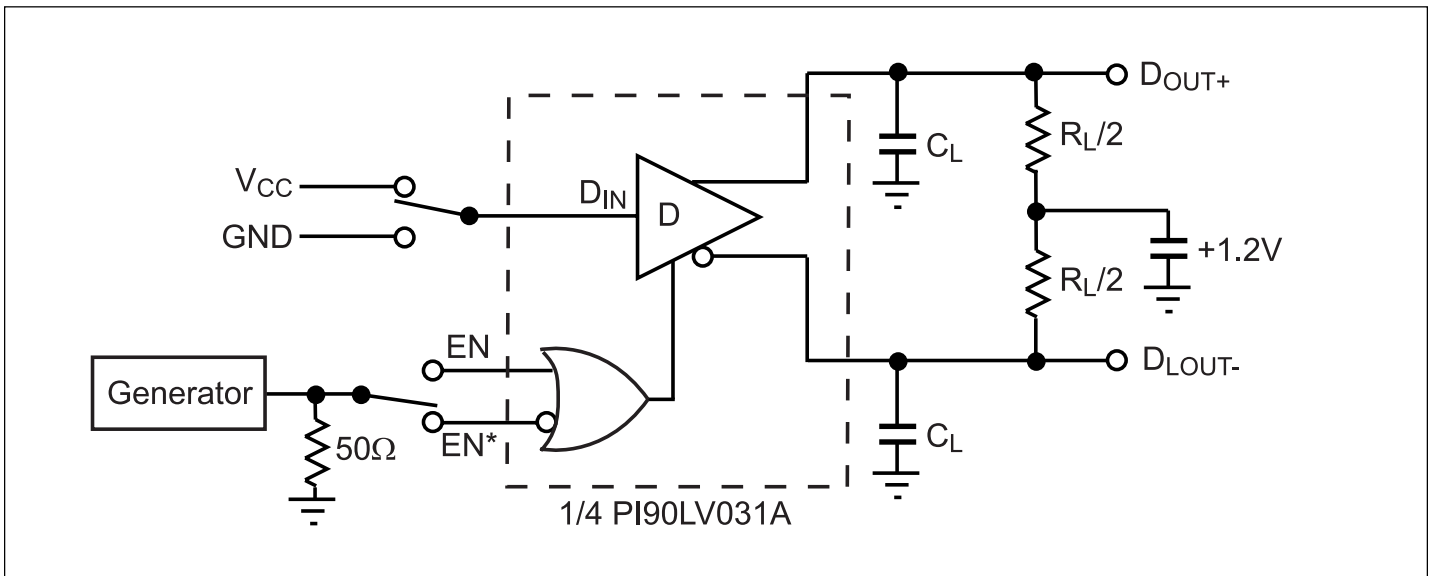

Figure 4. Driver Three-State Delay Test Circuit

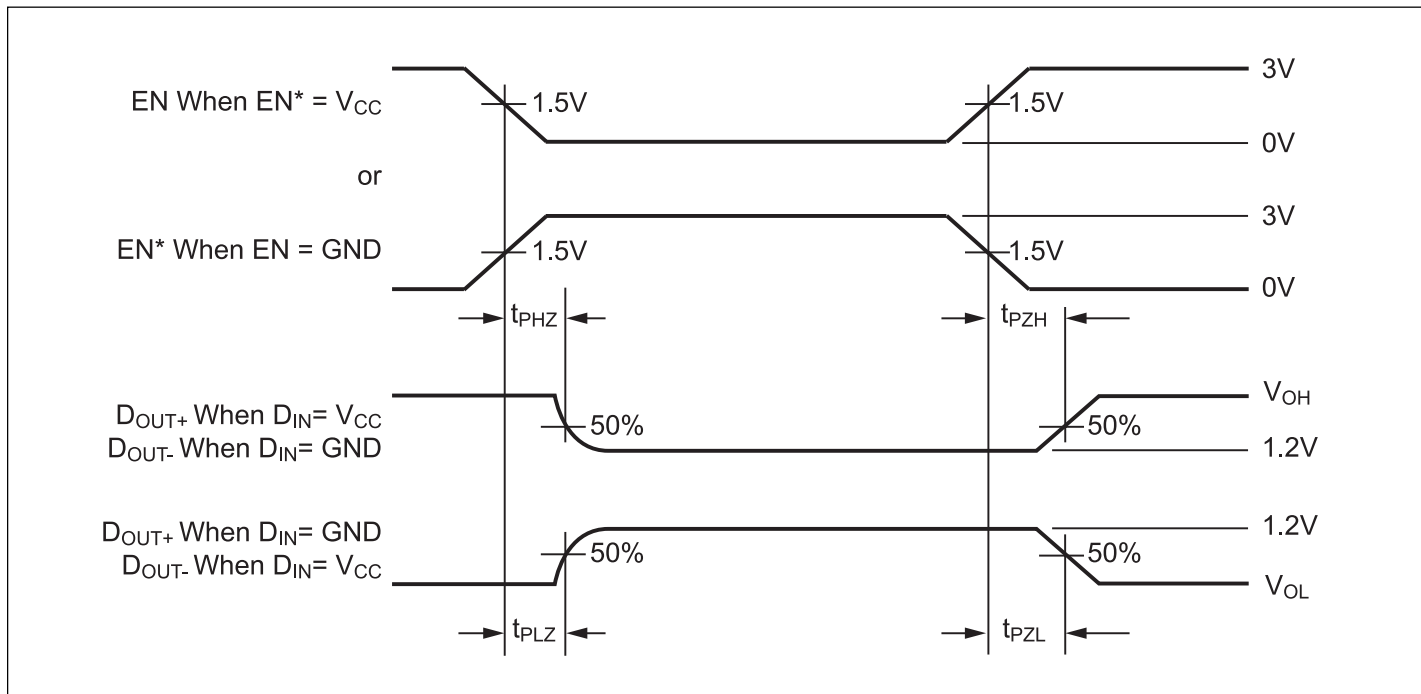

Figure 5. Driver Three-State Delay Waveform

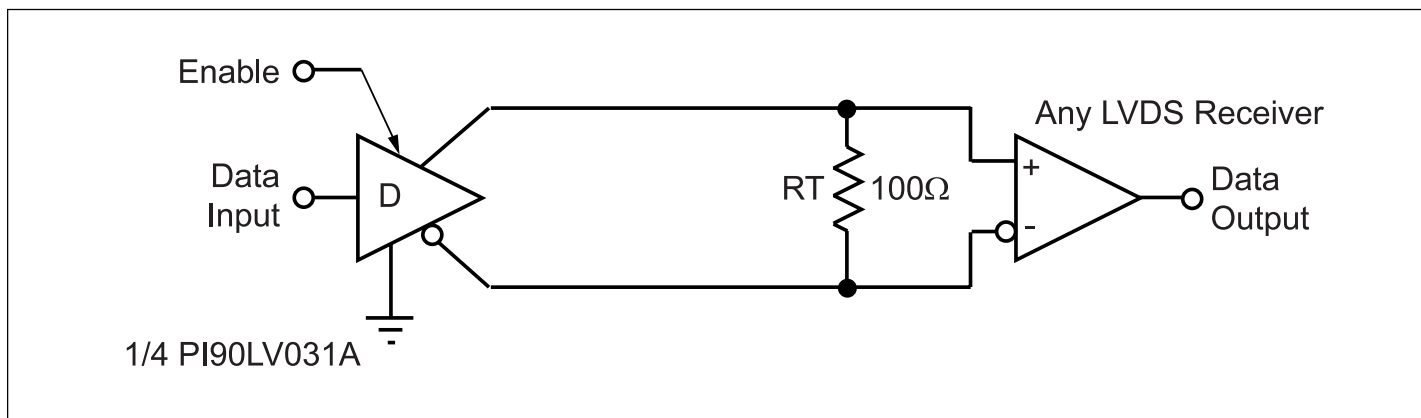
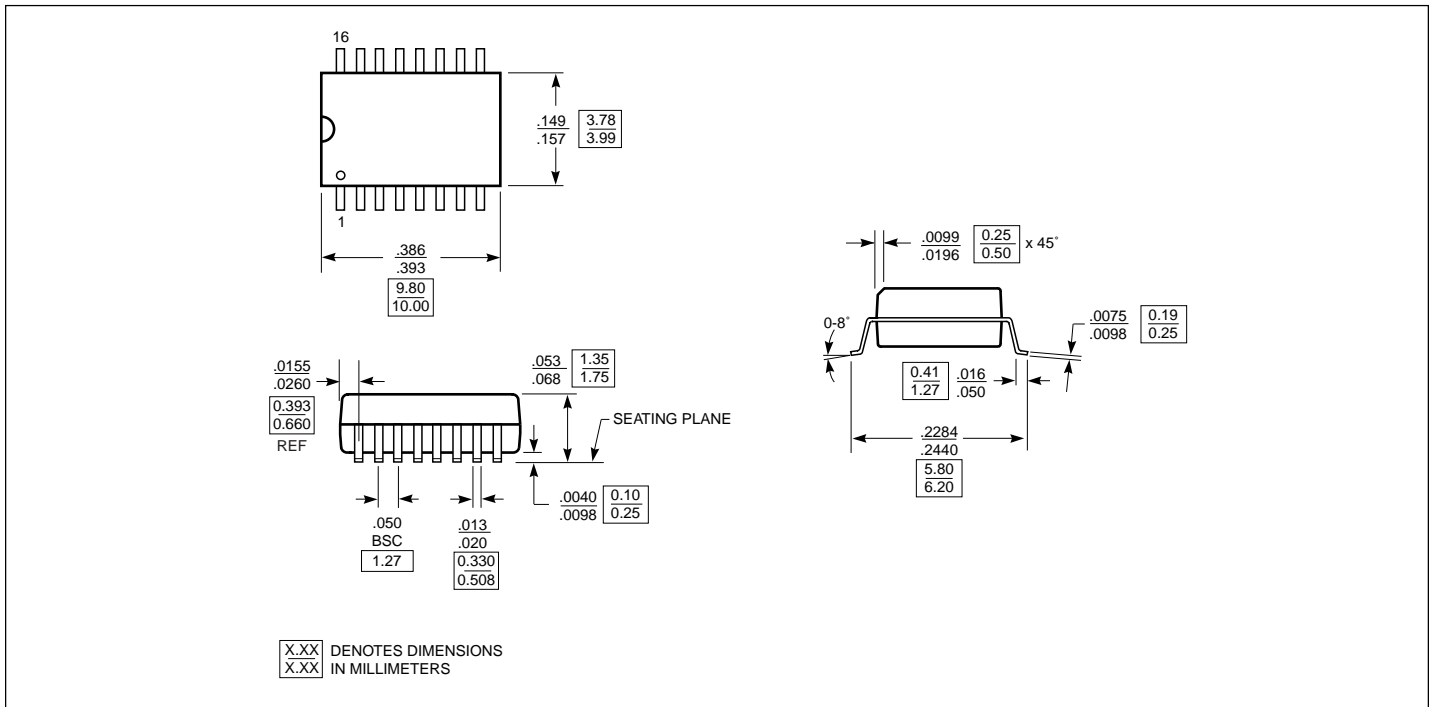

Figure 6. Point-to-Point Application



PI90LV031A/PI90LV027A/PI90LV017A
3V LVDS High-Speed Differential Line Drivers

16-Pin SOIC (150 Mil) W Package



8-Pin SOIC (150 Mil) W Package

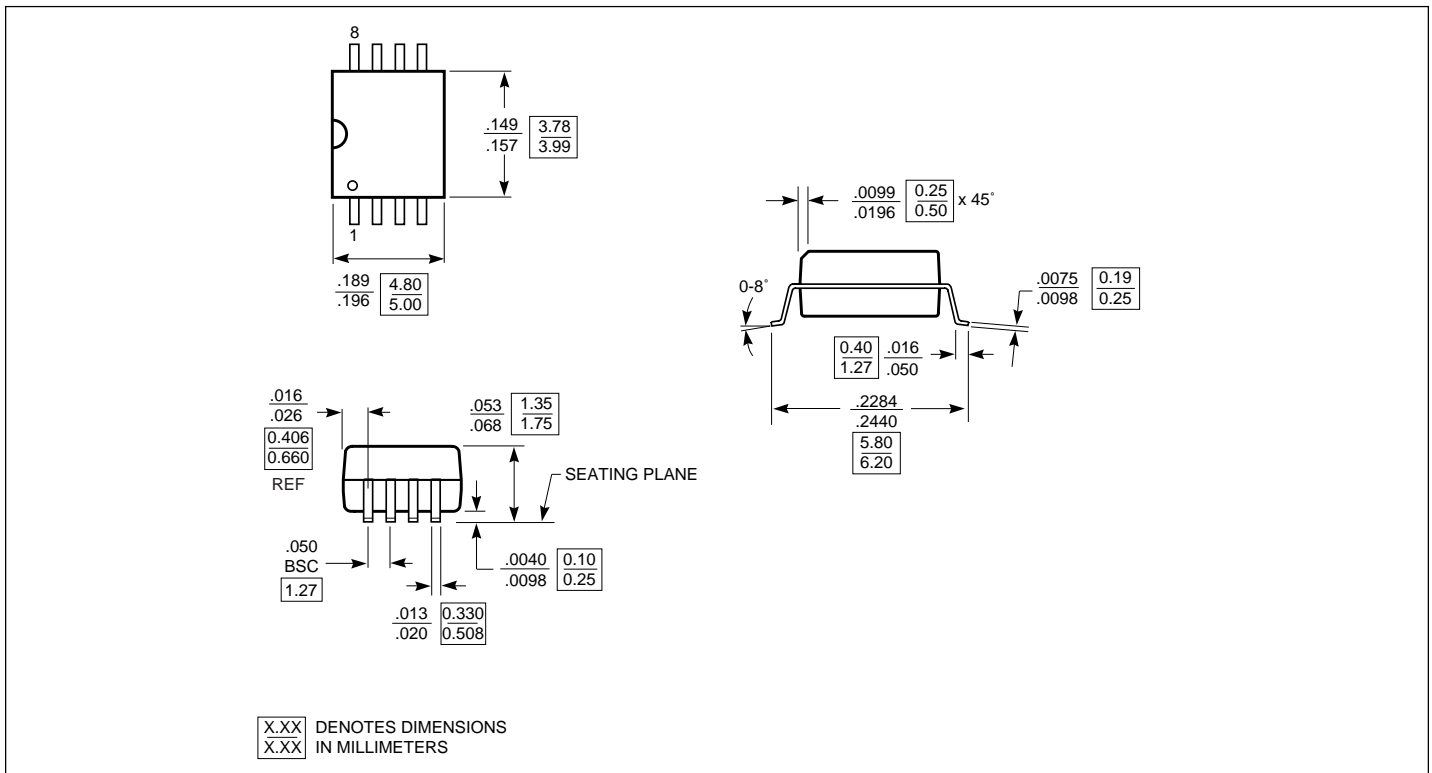

16-Pin TSSOP (4.4mm wide) L Package

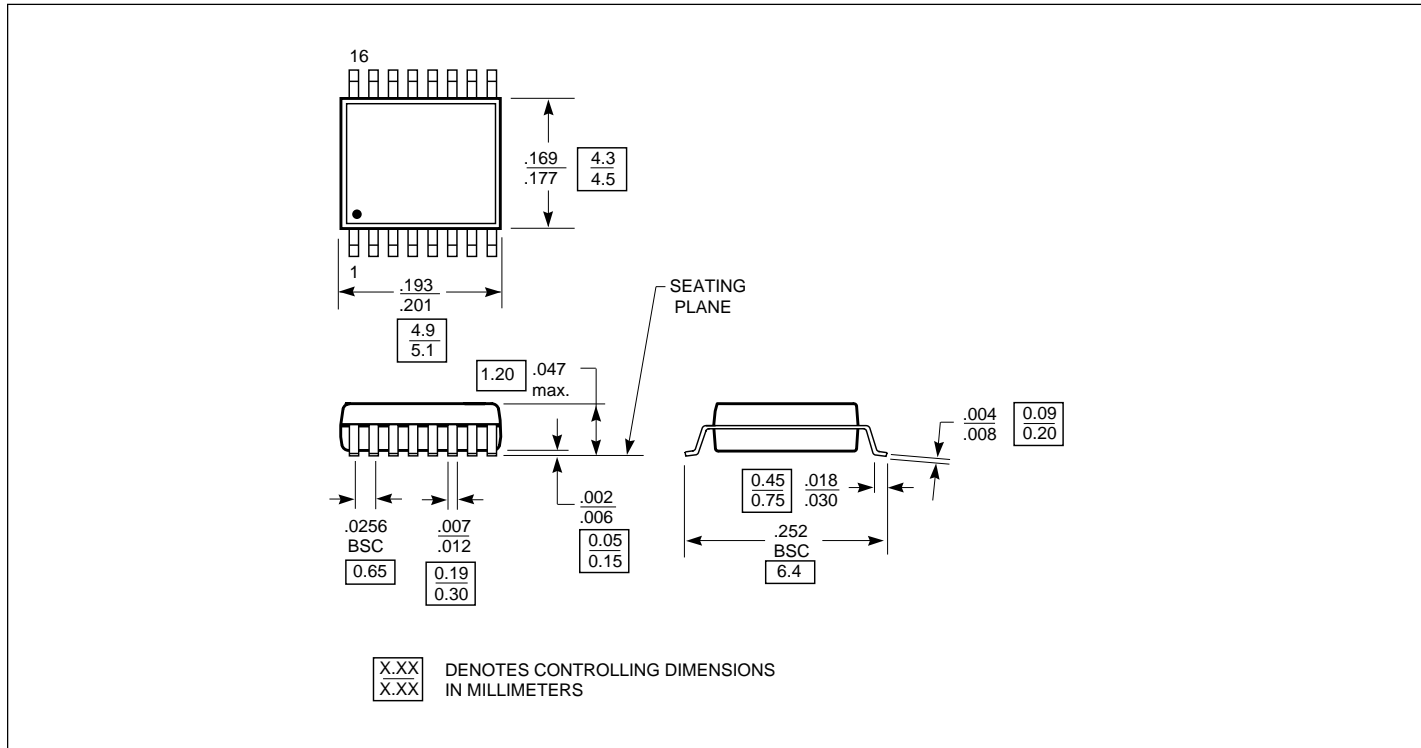

8-Pin Mini Small Outline U Package (MSOP)

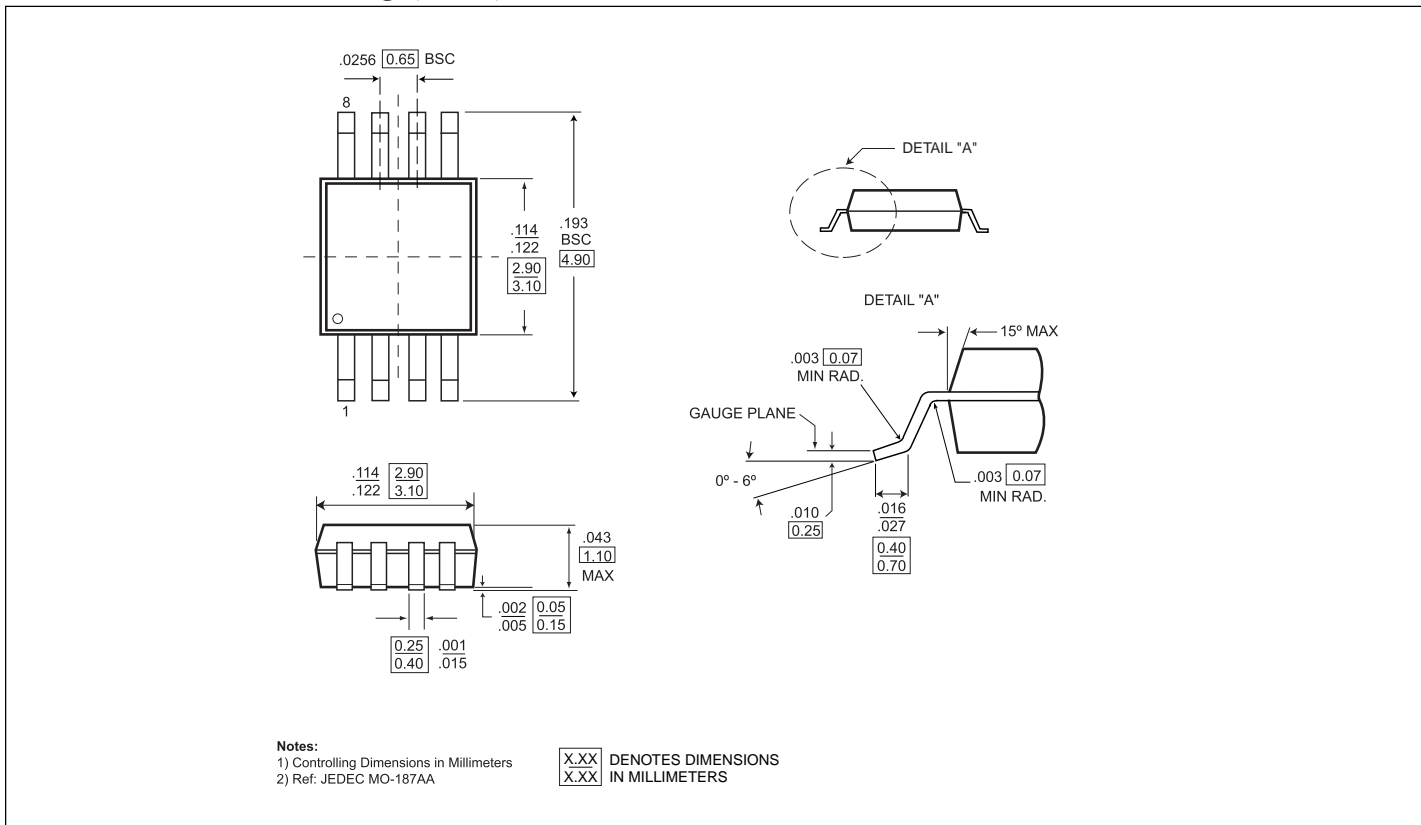



PI90LV031A/PI90LV027A/PI90LV017A
3V LVDS High-Speed Differential Line Drivers

.....

Ordering Information

Part	Pin-Package	Temperature
PI90LV031AW	16-SOIC	-40°C to 85°C
PI90LV027AW	8-SOIC	-40°C to 85°C
PI90LV017AW	8-SOIC	-40°C to 85°C
PI90LV031AL	16-TSSOP	-40°C to 85°C
PI90LV027AU	8-MSOP	-40°C to 85°C
PI90LV017AU	8-MSOP	-40°C to 85°C