



PI74ALVC16835

18-Bit Universal Bus Driver with 3-State Outputs

Product Features

- PI74ALVC16835 is designed for low voltage operation, $V_{CC}=2.3V$ to $3.6V$
- Supports PC100 Registered DIMM
- Typical V_{OLP} (Output Ground Bounce) $<0.8V$ at $V_{CC}=3.3V$, $T_A=25^{\circ}C$
- Typical V_{OHV} (Output V_{OH} Undershoot) $<2.0V$ at $V_{CC}=3.3V$, $T_A=25^{\circ}C$
- Industrial operation at $-40^{\circ}C$ to $+85^{\circ}C$
- Packages available:
 - 56-pin 240 mil wide plastic TSSOP (A)
 - 56-pin 173 mil wide plastic TVSOP (K)
 - 56-pin 300 mil wide plastic SSOP (V)

Product Description

Pericom Semiconductor's PI74ALVC series of logic circuits are produced in the Company's advanced 0.5 micron CMOS technology, achieving industry leading speed.

The 18-bit PI74ALVC16835 universal bus driver is designed for 2.3V to 3.6V V_{CC} operation.

Data flow from A to Y is controlled by Output Enable (\overline{OE}). The device operates in the transparent mode when LE is HIGH. The A data is latched if CLK is held at a high or low logic level. If LE is LOW, the A-bus is stored in the latch/flip-flop on the low-to-high transition of CLK. When \overline{OE} is HIGH, the outputs are in the high-impedance state.

To ensure the high-impedance state during power up or power down, \overline{OE} should be tied to V_{CC} through a pullup resistor; the minimum value of the resistor is determined by the current-sinking capability of the driver.

Logic Block Diagram

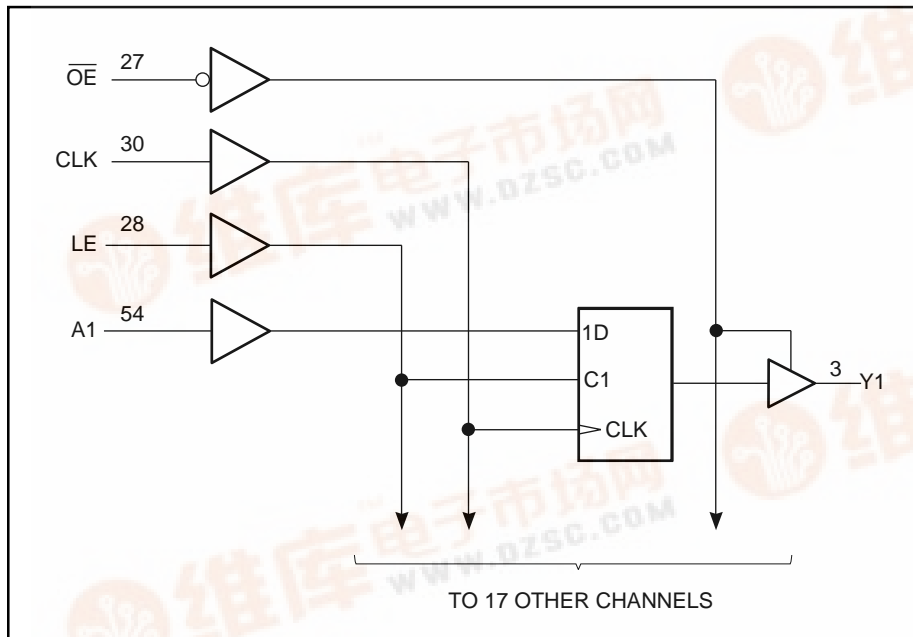



Product Pin Description

Pin Name	Description
\overline{OE}	Output Enable Input (Active LOW)
LE	Latch Enable
CLK	Clock Input
A	Data Input
Y	Data Output
GND	Ground
Vcc	Power

Truth Table^{(1)†}

Inputs				Outputs Y
\overline{OE}	LE	CLK	A	
H	X	X	X	Z
L	H	X	L	L
L	H	X	H	H
L	L	↑	L	L
L	L	↑	H	H
L	L	H	X	Y ₀ ⁽²⁾
L	L	L	X	Y ₀ ⁽³⁾

Product Pin Configuration

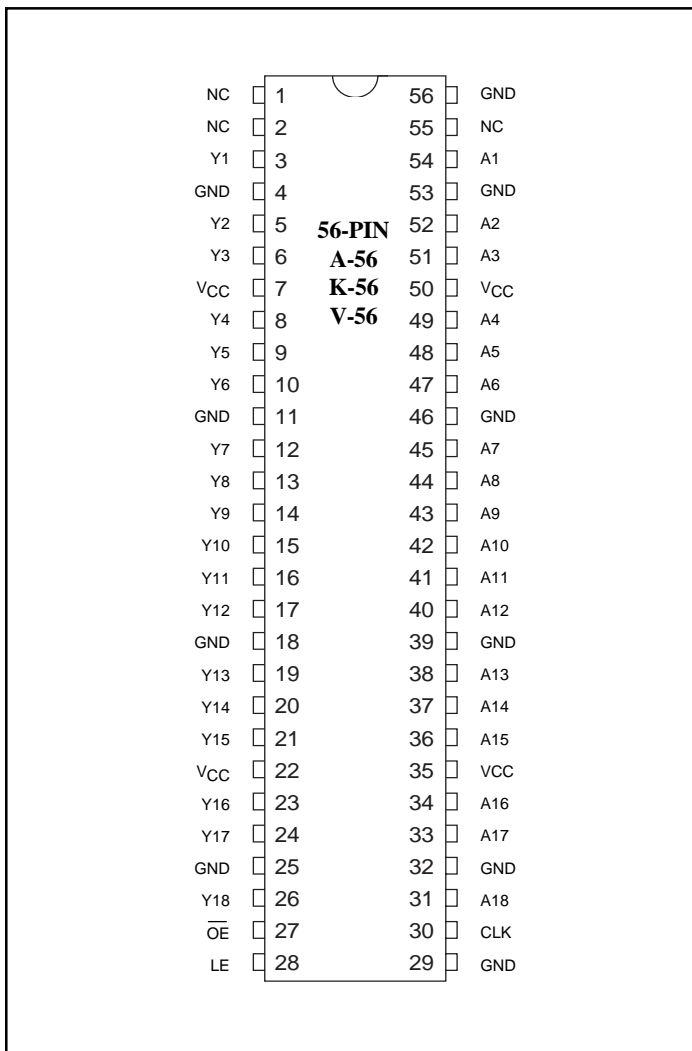

Note:

- 1 H = High Signal Level
 L = Low Signal Level
 Z = High Impedance
 ↑ = Transition LOW-to-HIGH
 X = Irrelevant
2. Output level before the indicated steady-state input conditions were established, provided that CLK is high before LE goes low.
3. Output level before the indicated steady-state input conditions were established.



Maximum Ratings

(Above which the useful life may be impaired. For user guidelines, not tested.)

Storage Temperature	-65°C to +150°C
Ambient Temperature with Power Applied	-40°C to +85°C
Input Voltage Range, V _{IN}	-0.5V to V _{CC} +0.5V
Output Voltage Range, V _{OUT}	-0.5V to V _{CC} +0.5V
DC Input Voltage	-0.5V to +5.0V
DC Output Current	100 mA
Power Dissipation	1.0W

Note:
 Stresses greater than those listed under MAXIMUM RATINGS may cause permanent damage to the device. This is a stress rating only and functional operation of the device at these or any other conditions above those indicated in the operational sections of this specification is not implied. Exposure to absolute maximum rating conditions for extended periods may affect reliability.

Recommended Operating Conditions⁽¹⁾

Parameters	Description	Test Conditions	Min.	Typ.	Max.	Units
V _{CC}	Supply Voltage		2.3		3.6	V
V _{IH}	Input HIGH Voltage	V _{CC} = 2.3V to 2.7V	1.7			
		V _{CC} = 2.7V to 3.6V	2.0			
V _{IL}	Input LOW Voltage	V _{CC} = 2.3V to 2.7V			0.7	
		V _{CC} = 2.7V to 3.6V			0.8	
V _{IN}	Input Voltage		0		V _{CC}	
V _{OUT}	Output Voltage		0		V _{CC}	
I _{OH}	High-level Output Current	V _{CC} = 2.3V			-12	mA
		V _{CC} = 2.7V			-12	
		V _{CC} = 3.0V			-24	
I _{OL}	Low-level Output Current	V _{CC} = 2.3V			12	
		V _{CC} = 2.7V			12	
		V _{CC} = 3.0V			24	
T _A	Operating Free-Air Temperature		-40		85	°C

Note:

1. Unused control inputs must be held HIGH or LOW to prevent them from floating.

DC Electrical Characteristics (Over the Operating Range, $T_A = -40^{\circ}\text{C}$ to $+85^{\circ}\text{C}$, $V_{CC} = 3.3\text{V} \pm 10\%$)

Parameters	Test Conditions		$V_{CC}^{(1)}$	Min.	Typ. ⁽²⁾	Max.	Units
V_{OH}	$I_{OH} = -100 \mu\text{A}$		Min. to Max.	$V_{CC} - 0.2$			V
	$I_{OH} = -6 \text{ mA}$	$V_{IH} = 1.7\text{V}$	2.3V	2.0			
	$I_{OH} = -12 \text{ mA}$	$V_{IH} = 1.7\text{V}$	2.3V	1.7			
		$V_{IH} = 2.0\text{V}$	2.7V	2.2			
		$V_{IH} = 2.0\text{V}$	3.0V	2.4			
$I_{OH} = -24 \text{ mA}$	$V_{IH} = 2.0\text{V}$	3.0V	2.0				
V_{OL}	$I_{OL} = 100 \mu\text{A}$		Min. to Max.			0.2	
	$I_{OL} = 6 \text{ mA}$	$V_{IL} = 0.7\text{V}$	2.3V			0.4	
	$I_{OL} = 12 \text{ mA}$	$V_{IL} = 0.7\text{V}$	2.3V			0.7	
		$V_{IL} = 0.8\text{V}$	2.7V			0.4	
	$I_{OL} = 24 \text{ mA}$	$V_{IL} = 0.8\text{V}$	3.0V			0.55	
I_I	$V_I = V_{CC}$ or GND		3.6V			± 5	μA
$I_{OZ}^{(3)}$	$V_O = V_{CC}$ or GND		3.6V			± 5	
I_{CC}	$V_I = V_{CC}$ or GND	$I_O = 0$	3.6V			40	
ΔI_{CC}	One input at $V_{CC} - 0.6\text{V}$, Other inputs at V_{CC} or GND		3V to 3.6V			750	
C_I Control Inputs	$V_I = V_{CC}$ or GND		3.3V		3.5		pF
Data Input	$V_O = V_{CC}$ or GND		3.3V		6		
C_O Outputs	$V_O = V_{CC}$ or GND		3.3V		7		

Notes:

1. For Max. or Min. conditions, use appropriate value specified under Electrical Characteristics for the applicable device type.
2. Typical values are at $V_{CC} = 3.3\text{V}$, $+25^{\circ}\text{C}$ ambient and maximum loading.
3. For I/O ports, the I_{OZ} includes the input leakage current.

Timing Requirements over Operating Range

Parameters	Description	$V_{CC} = 2.5 \text{ V} \pm 0.2\text{V}$		$V_{CC} = 2.7\text{V}$		$V_{CC} = 3.3\text{V} \pm 0.3\text{V}$		Units
		Min.	Max.	Min.	Max.	Min.	Max.	
f_{CLOCK}	Clock frequency	0	150	0	150	0	150	MHz
t_W Pulse Duration	$\overline{\text{LE}}$ high	3.3		3.3		3.3		ns
	CLK high or low	3.3		3.3		3.3		
t_{SU} Setup time	Data before CLK \uparrow	2.2		2.1		1.7		
	Data before $\overline{\text{LE}} \downarrow$, CLK High	1.9		1.6		1.5		
	Data before $\overline{\text{LE}} \downarrow$, CLK Low	1.3		1.1		1		
t_H Hold time	Data after CLK \uparrow	0.6		0.6		0.7		
	Data after $\overline{\text{LE}} \downarrow$, CLK High or Low	1.4		1.7		1.4		
$\Delta t/\Delta v^{(1)}$	Input Transition Rise or Fall	0	10	0	10	0	10	ns/V

Note:

1. Unused control inputs must be held HIGH or LOW to prevent them from floating.



Switching Characteristics Over Operating Range⁽¹⁾

Parameter	From (Input)	To (Output)	V _{CC} = 2.5V ± 0.2V		V _{CC} = 2.7V		V _{CC} = 3.3 V ± 0.3V		Units
			Min. ⁽²⁾	Max.	Min. ⁽²⁾	Max.	Min. ⁽²⁾	Max.	
f _{MAX}			150		150		150		MHz
t _{PD}	A	Y	1	4.2		4.2	1	3.6	ns
t _{PD}	\overline{LE}	Y	1.3	5		4.9	1.3	4.2	
t _{PD}	CLK	Y	1.4	5.5		5.2	1.4	4.5	
t _{EN}	\overline{OE}	Y	1.4	5.5		5.6	1.1	4.6	
t _{DIS}	\overline{OE}	Y	1	4.5		4.3	1.3	3.9	

Notes:

1. See test circuit and wave forms.
2. Minimum limits are guaranteed but not tested on Propagation Delays.

Switching Characteristics, from 0°C to 65°C, CL = 50pF

Parameters	From (Input)	To (Output)	V _{CC} = 3.3V ± 0.15V		Units
			Min.	Max.	
t _{PD}	CLK	Y	1.7	4.5	ns

Operating Characteristics, T_A = 25°C

Parameters		Test Conditions	V _{CC} = 2.5V ± 0.2V	V _{CC} = 3.3V ± 0.3V	Units
			Typical	Typical	
C _{PD} Power Dissipation Capacitance	Outputs Enabled	C _L = 50pF, F = 10 MHz	26	31	pF
	Outputs Disabled		12	14	