



**PI3B16209  
PI3B162209 (25Ω)  
3.3V, 18-Bit Bus  
Exchange Switch**

**Product Features:**

- Near-zero propagation delay
- 5Ω switches connect inputs to outputs
- Fast Switching speed - 5ns (max.)
- Operating Range: 2.3V to 3.6V
- Industrial operating temperature: -40°C to +85°C
- Packages available:
  - 48-pin 240-mil wide thin plastic TSSOP (A48)
  - 48-pin 300-mil wide plastic SSOP (V48)

**Product Description:**

Pericom Semiconductor's PI3B series of logic circuits are produced in the Company's advanced 0.35 micron CMOS technology.

The PI3B16209 and PI3B162209 are 3.3 volt 18-bit bus exchange switches designed with a low ON resistance (5Ω) allowing inputs to be connected directly to outputs. This device operates as a 18-bit bus switch or a 9-bit exchanger, which provides data exchanging between the four signal ports via the data select pins (S0-S2).

The PI5C162209 device has a built-in 25 ohm series resistor to reduce noise due to reflections, thus eliminating the need for an external terminating resistor.

**Logic Block Diagram**

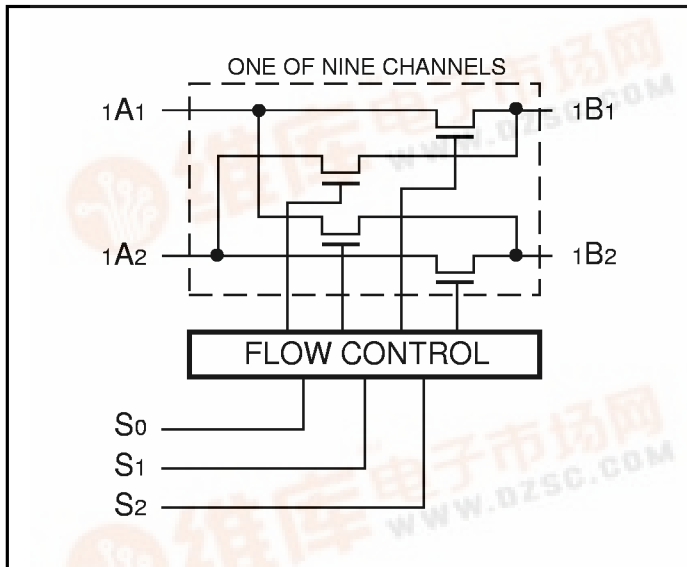

**Product Pin Configuration**

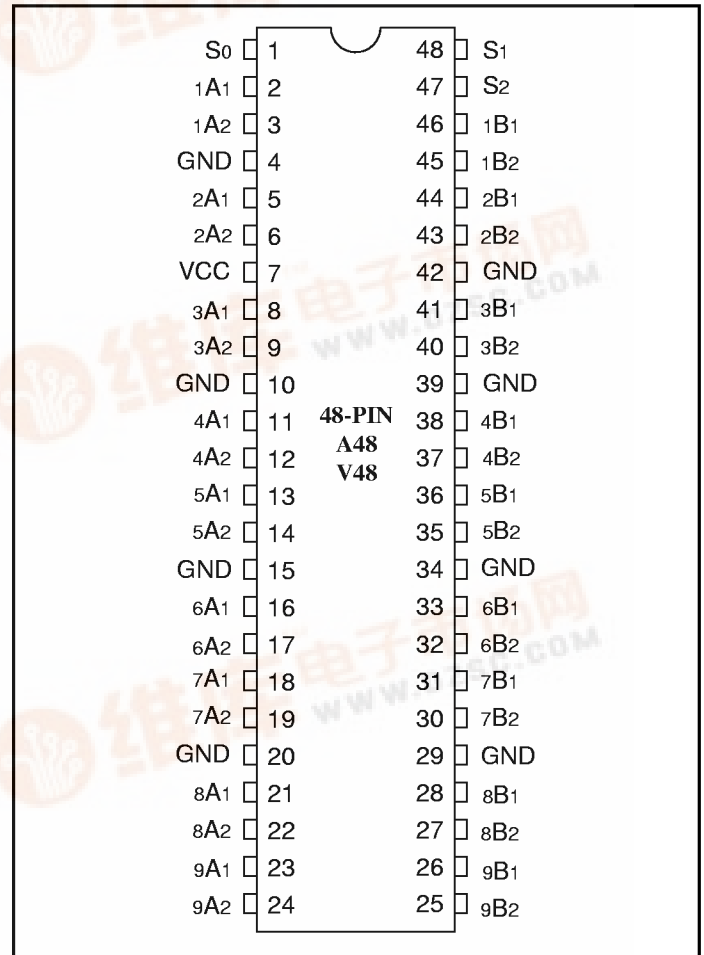

**Truth Table**

Function	S2	S1	S0	A1	A2
Disconnect	L	L	L	Z	Z
A1 to B1	L	L	H	B1	Z
A1 to B2	L	H	L	B2	Z
A2 to B1	L	H	H	Z	B1
A2 to B2	H	L	L	Z	B2
Disconnect	H	L	H	Z	Z
A1 to B1, A2 to B2	H	H	L	B1	B2
A1 to B2, A2 to B1	H	H	H	B2	B1

**Note:**

- H = High Voltage Level
- L = Low Voltage Level
- Z = High Impedance

**Product Pin Description**

Pin Name	I/O	Description
S0-S2	I	Select Inputs
xAx	I/O	Bus A
xBx	I/O	Bus B

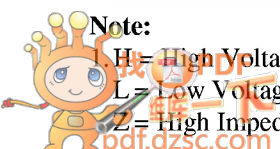



PRELIMINARY

PI3B16209/162209  
3.3V, 18-BIT BUS-EXCHANGE SWITCH

### Maximum Ratings

(Above which the useful life may be impaired. For user guidelines, not tested.)

Storage Temperature .....	-65°C to +150°C
Ambient Temperature with Power Applied .....	-0°C to +85°C
Supply Voltage Range .....	-0.5V to +4.6V
DC Input Voltage .....	-0.5V to +4.6V
DC Output Current .....	120 mA
Power Dissipation .....	0.5W

**Note:**

Stresses greater than those listed under MAXIMUM RATINGS may cause permanent damage to the device. This is a stress rating only and functional operation of the device at these or any other conditions above those indicated in the operational sections of this specification is not implied. Exposure to absolute maximum rating conditions for extended periods may affect reliability.

### DC Electrical Characteristics (Over the Operating Range, T<sub>A</sub> = -40°C to +85°C, V<sub>CC</sub> = 3.0V to 3.6V)

Parameters	Description	Test Conditions <sup>(1)</sup>	Min.	Typ <sup>(2)</sup>	Max.	Units	
V <sub>IH</sub>	Input HIGH Voltage	Guaranteed Logic HIGH Level	2.0	—	—	V	
V <sub>IL</sub>	Input LOW Voltage	Guaranteed Logic LOW Level	-0.5	—	0.8	V	
I <sub>IH</sub>	Input HIGH Current	V <sub>CC</sub> = Max., V <sub>IN</sub> = V <sub>CC</sub>	—	—	±1	µA	
I <sub>IL</sub>	Input LOW Current	V <sub>CC</sub> = Max., V <sub>IN</sub> = GND	—	—	±1	µA	
I <sub>OZH</sub>	High Impedance Output Current	0 ≤ A, B ≤ V <sub>CC</sub>	—	—	±1	µA	
V <sub>IK</sub>	Clamp Diode Voltage	V <sub>CC</sub> = Min., I <sub>IN</sub> = -18 mA	—	-0.7	-1.2	V	
R <sub>ON</sub>	Switch On Resistance <sup>(3)</sup>	V <sub>CC</sub> = Min., V <sub>IN</sub> = 0.0V,	16209	—	5	8	Ω
		I <sub>ON</sub> = 48 mA	162209	20	28	40	
		V <sub>CC</sub> = Min., V <sub>IN</sub> = 2.4V,	16209	—	10	15	Ω
		I <sub>ON</sub> = 15 mA	162209	20	35	48	

### Capacitance (T<sub>A</sub> = 25°C, f = 1 MHz)

Parameters <sup>(4)</sup>	Description	Test Conditions	Typ	Units
C <sub>IN</sub>	Input Capacitance	V <sub>IN</sub> = 0V	3	pF
C <sub>OFF</sub>	A/B Capacitance, Switch Off	V <sub>IN</sub> = 0V	8	pF
C <sub>ON</sub>	A/B Capacitance, Switch On	V <sub>IN</sub> = 0V	16	pF

**Notes:**

1. For Max. or Min. conditions, use appropriate value specified under Electrical Characteristics for the applicable device type.
2. Typical values are at V<sub>CC</sub> = 3.3V, T<sub>A</sub> = 25°C ambient and maximum loading.
3. Measured by the voltage drop between A and B pin at indicated current through the switch. ON resistance is determined by the lower of the voltages on the two (A,B) pins.
4. This parameter is determined by device characterization but is not production tested.



PRELIMINARY

PI3B16209/162209  
3.3V, 18-BIT BUS-EXCHANGE SWITCH

**Power Supply Characteristics**

Parameters	Description	Test Conditions <sup>(1)</sup>		Min.	Typ <sup>(2)</sup>	Max.	Units
I <sub>cc</sub>	Quiescent Power Supply Current	V <sub>CC</sub> = Max.	V <sub>IN</sub> = GND or V <sub>CC</sub>			500	μA
ΔI <sub>cc</sub>	Supply Current per Input @ TTL HIGH	V <sub>CC</sub> = Max.	V <sub>IN</sub> = 3.0V <sup>(3)</sup>			750	μA
I <sub>CCD</sub>	Supply Current per Input per MHz <sup>(4)</sup>	V <sub>CC</sub> = Max. A and B Pins Open $\overline{BE}$ = GND Control Input Toggling 50% Duty Cycle				0.25	mA/ MHz

**Notes:**

1. For Max. or Min. conditions, use appropriate value specified under Electrical Characteristics for the applicable device.
2. Typical values are at V<sub>CC</sub> = 3.3V, +25°C ambient.
3. Per TTL driven input (control input only); A and B pins do not contribute to I<sub>cc</sub>.
4. This current applies to the control inputs only and represent the current required to switch internal capacitance at the specified frequency. The A and B inputs generate no significant AC or DC currents as they transition. This parameter is not tested, but is guaranteed by design.

**Switching Characteristics over Operating Range**

Parameters	Description	Conditions <sup>(1)</sup>	Com.		Unit
			Min.	Max.	
t <sub>PLH</sub>	Propagation Delay <sup>(2,3)</sup> Ax to Bx, Bx to Ax	Cl = 50 pF Rl = 500Ω	16209	0.25	ns
t <sub>PHL</sub>			162209	1.25	
t <sub>PZH</sub>	Bus Enable Time $\overline{BE}$ to Ax or Bx	Cl = 50 pF, R <sub>L</sub> = 500Ω, R = 500Ω	1	4	
t <sub>PZL</sub>			1	5	
t <sub>PHZ</sub>	Bus Disable Time $\overline{BE}$ to Ax or Bx				
t <sub>PLZ</sub>					

**Notes:**

1. See test circuit and waveforms.
2. This parameter is guaranteed but not tested on Propagation Delays.
3. The bus switch contributes no propagational delay other than the RC delay of the ON resistance of the switch and the load capacitance. The time constant for the switch alone is of the order of 0.25 ns for 50 pF load. Since this time constant is much smaller than the rise/fall times of typical driving signals, it adds very little propagational delay to the system. Propagational delay of the bus switch when used in a system is determined by the driving circuit on the driving side of the switch and its interaction with the load on the driven side.

DOCUMENT CONTROL NO.

PD-1401

REVISION:

DATE: 11/13/95

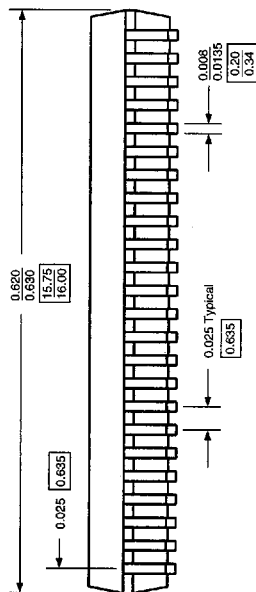
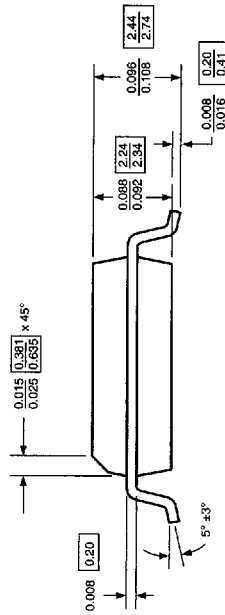
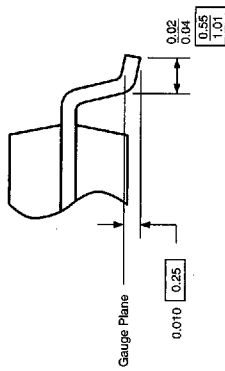
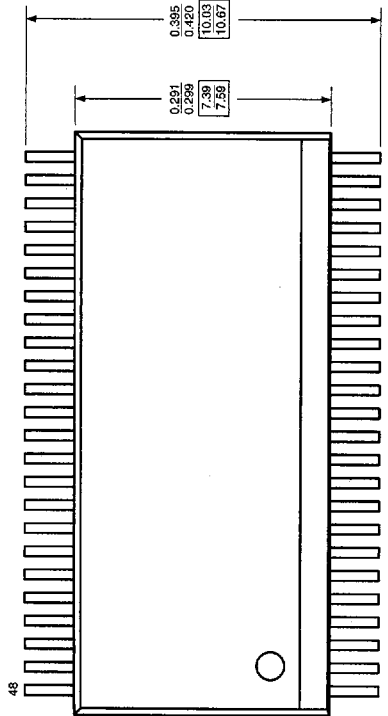

X.XX  
X.XX  
IN MILLIMETERS



Pericom Semiconductor Corporation  
2380 Bering Drive • San Jose, CA 95131  
Tel: (408) 435-0800 • Fax: (408) 435-1100

DESCRIPTION: 48-PIN SSOP (300 MIL WIDE)

PACKAGE CODE: V48

PACKAGE MECHANICAL DIMENSIONS

DOCUMENT CONTROL NO.

PD- 1501

REVISION:

DATE: 11/13/95

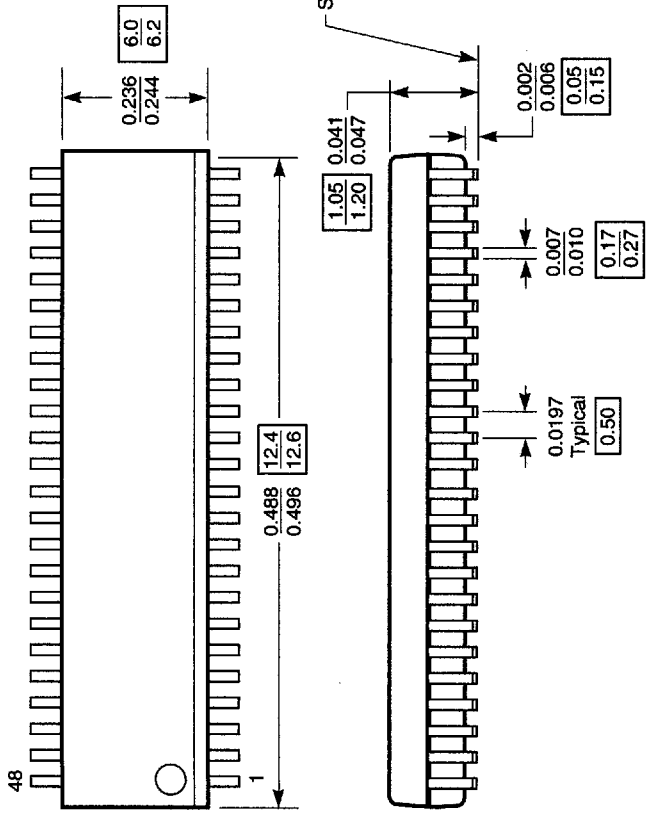

X.XX  
X.XX

DENOTES DIMENSIONS  
IN MILLIMETERS

PACKAGE  
MECHANICAL DIMENSIONS



Pericom Semiconductor Corporation  
2380 Bering Drive • San Jose, CA 95131  
Tel: (408) 435-0800 • Fax: (408) 435-1100

DESCRIPTION: 48-PIN TSSOP (240 MIL WIDE)  
PACKAGE CODE: A48