



Power Inlets & Outlets

Selection Guide

CONNECTORS

No. Pins	Flange Fixing	Push-fit	Fused Flange	Fused Push-Fit	Filtered	Fused Filtered	Rewirable	Rewirable Side Entry	Non-Rewirable	Non-Rewirable Side Entry
BS4491 (Cold Condition) Inlets Standard Sheet C8 (EN60 320)							EN60 320 (Cold Condition) Mating Connectors Standard Sheet C7			
2	PX0784	PX0785			-	-	-	-	-	-
2	PX0786 (PC Mount)				-	-	-	-	-	-
BS4491 (Cold Condition) Inlets Standard Sheet C18 (EN60 320)							EN60 320 (Cold Condition) Mating Connectors Standard Sheet C17			
2	PX0690	PX0691 PX0691/PC	PF0006 & 7	PF0016	-	-	-	-	-	-
BS4491 (Cold Condition) Inlets Standard Sheet C14 (EN60 320)							BS4491 (Cold Condition) Mating Connectors Standard Sheet C13 (EN60 320)			
3	PX0579 PX0580 PX0580/PC PX0580/PC/12132 PX0580/PC/7 PX0580/PC/7LC	PX0575 PX0575/PC	PF0001 PF0001/PC PF0002 PF0030 PF0030/PC	PF0011 PF0011/PC PF0033	See Pages 88-97, 114-119.	See Pages 126-133.	PX0587	PX0587/SE PX0588	PZ0100	PZ0200
BS4491 (Hot Condition) Inlets Standard Sheet C16 (EN60 320)							BS4491 (Hot Condition) Mating Connectors Standard Sheet C15 (EN60 320)			
3	PX0590	PX0595	-	-	-	-	PX0597	-	-	-
BS EN60 320 - 2 - 2 Outlets. Standard Sheet H.							Mating Connectors Standard Sheet G.			
2	PX0705	PX0725	-	-	-	-	-	-	-	-
BS EN60 320 - 2 - 2 Outlets. Standard Sheet F.							Mating Connectors Standard Sheet E.			
3	PX0675 PX0675/PC PX0675/PC/12599	PX0695 PX0695/PC PX0714	-	-	-	-	PX0686 PX0685 PX0686/SE	PZ0500	PZ0600	
3 Shuttered	PX0793	PX0783								
Appliance Outlets 6A							Mating Connectors 6A			
3	PX0780 +PNo 11610 & /1	PX0780	-	-	-	-	PX0770	-	-	-
BS 1363/A										
3	-	-	-	-	-	-	-	-	PZ0800	-
General Purpose (Round Pin) Inlet							Mating General Purpose (Round Pin) Connectors			
3	PX0429	-	-	-	-	-	PX0646	PX0430/SE	-	-
6	PX0635	-	-	-	-	-	PX0636	-	-	-
3	SA2341	-	-	-	-	-	-	-	-	-
3	SA2096	-	-	-	-	-	-	SA2097	-	-
General Purpose (Round Pin) Outlet							Mating General Purpose (Round Pin) Connectors			
3	SA2404	-	-	-	-	-	-	SA2403	-	-
4	SA2368	-	-	-	-	-	-	SA2367	-	-
3	PX0650	-	-	-	-	-	PX0649	-	-	-
8	PX0552	-	-	-	-	-	-	PX0551	-	-
8	PX0552/PC	-	-	-	-	-	-	PX0551	-	-
8	PX0957	-	-	-	-	-	-	PX0956	-	-
8	PX0958	-	-	-	-	-	-	PX0956	-	-



Certificate No. FM12822

Retaining Clips (to prevent accidental removal of connectors)	Insulation Boots	Adaptor Flange (to covert Push-Fit type PX0780)
KT0006 for PX0580 + PX0587 or PZ0100 PX0590 + PZ0597 PX0675 + PX0686 or PZ0500 PX0793 + PX0686 or PZ0500	PNo 8878 for SA2341 PNo 9455 for PX0429, PX0635, PX0650, SA2368, SA2404 PNo11328 for PX0575, PX0579, PX0580, PX0590, PX0595 PNo 11987 for PF Range (except /PC & PF0030, PF0033) PNo 12075 for PX0675, PX0695 (except/PC) & PX0783, PX0793 PNo 12122 for PX0780	PNo 11610 (With countersunk holes) PNo 11610/1 (Holes not countersunk, for use with KT0007)
KT0007 for PX0780 + 11610/1 + PX0770 KT0009 for Polysnap + PX0587 or PZ0100 PF0001, PF0001/PC + PX0587 or PZC100 PF0002 + PX0587 or PZ0100 PF0030 + PX0587 or PZ0100		



EN60 320 (BS4491 Standard Sheet C8 Class II) Cold Condition

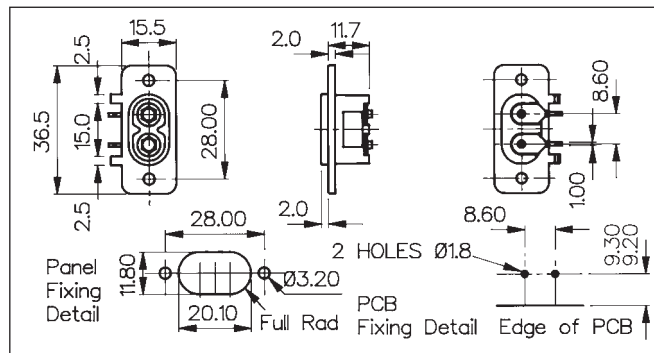
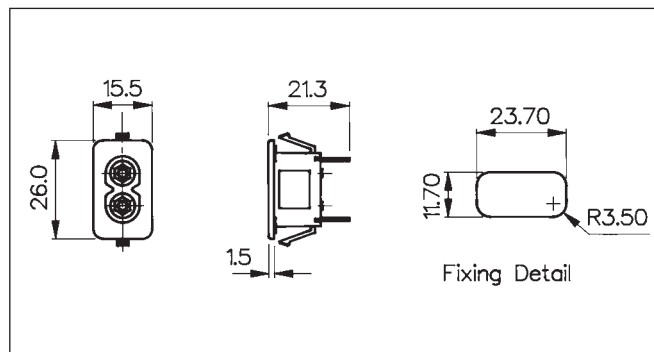
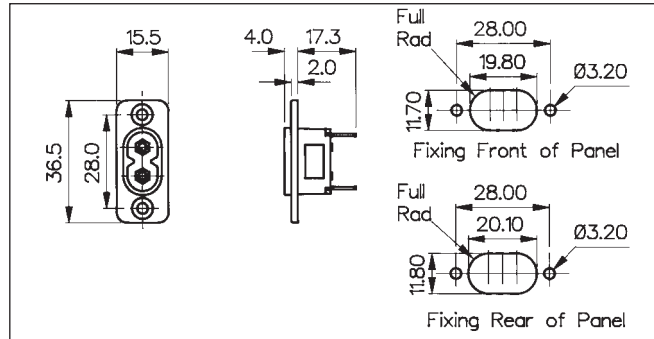

CONNECTORS



Data	List No.	PX0784/28	PX0785/28	PX0786/PC
Fixing:		Flange.	Push Fit. 1mm, 1.5mm, 2mm	PCB/Flange.
Terminations:		/28 (2.8mm solder).	/28 (2.8mm solder).	P. C. Spills
Max. Rating:		2.5A. 250V a.c.	2.5A. 250V a.c.	2.5A. 250V a.c.
Contact Resistance:		<10mΩ.	<10mΩ.	<10mΩ.
Insulation Resistance:		>10 ⁵ MΩ @ 500V d.c.	>10 ⁵ MΩ @ 500V d.c.	>10 ⁵ MΩ @ 500V d.c.
A.C. Breakdown:		4kV.	4kV.	4kV.
Operating Temp. Range:		-40°C to +70°C.	-40°C to +70°C.	-40°C to +70°C.
Max. Pin Temp.:		+70°C.	+70°C.	+70°C.
Mouldings:		Nylon, Flammability Rating UL.94V-O.	Nylon, Flammability Rating UL.94V-O.	Nylon, Flammability Rating UL.94V-O.
Contacts:		Brass: Pins, Nickel Plated. Tabs, Tin Plated.	Brass: Pins, Nickel Plated. Tabs, Tin Plated.	Brass: Pins, Nickel Plated. Spills, Tin Plated.
Approvals:				
Accessories / Notes:		-	-	-
Mating Connectors:		-	-	-



IEC Power Inlets

EN60 320 (BS4491 Standard Sheet C14 Class I) Cold Condition

CONNECTORS

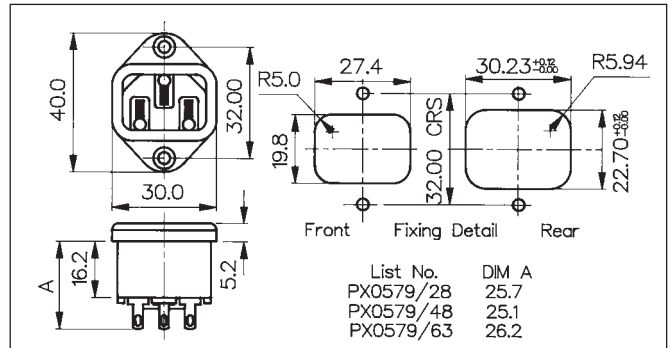
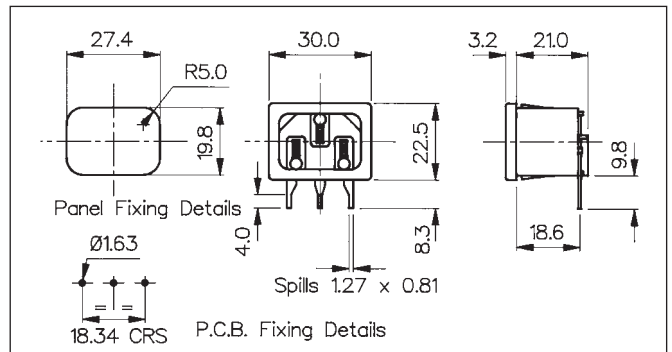
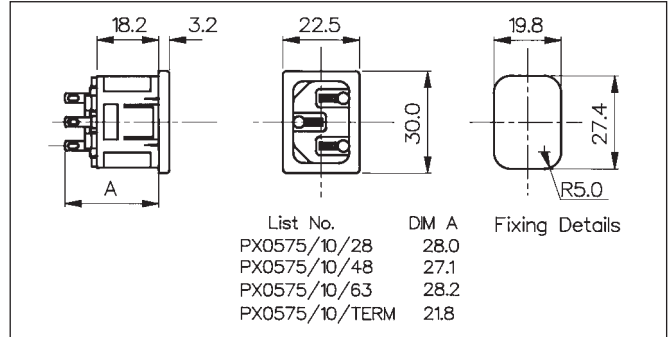

Data	List No.	PX0575/Panel/Termination	PX0575/Panel/PC	PX0579/Termination
Fixing (Panel):		Push-fit. /10 (1mm), /15 (1.5mm), /20 (2mm), /30 (3mm).	Push-fit. /10 (1mm), /15 (1.5mm), /20 (2mm), /30 (3mm).	Flange.
Terminations:		/28 (2.8mm solder), /48 (4.8mm tab), /63 (6.3mm tab), /TERM (screw).	P.C. Spills.	/28 (28mm solder), /48 (4.8mm tab), /63 (6.3mm tab).
Max. Rating:		10A. 250V a.c. (UL & CSA 15A 250V a.c.).	10A, 250V a.c. (UL & CSA 15A 250V a.c.).	10A. 250V a.c. (UL & CSA 15A 250V a.c.)
Contact Resistance:		<10mΩ.	<10mΩ.	<10mΩ.
Insulation Resistance:		>10 ³ MΩ.	>10 ³ MΩ.	>10 ³ MΩ.
A.C. Breakdown:		Pole-Pole 5kV. Poles-Panel 5.4kV.	Pole-Pole 5kV. Poles-Panel 5.4kV.	Pole-Pole 5kV. Poles-Panel 10kV.
Operating Temp. Range:		-40°C to + 70°C.	-40°C to + 70°C.	-40°C to + 70°C.
Max. Pin Temp.:		+70°C.	+70°C.	+70°C.
Mouldings:		Nylon, Flammability Rating UL.94V-O.	Nylon, Flammability Rating UL.94V-O.	Nylon, Flammability Rating UL.94V-O.
Contacts:		Brass: Pins, Nickel Plated. Tabs, Tin Plated. Screw Terms, Nickel Plated.	Brass: Pins, Nickel Plated. Spills, Tin Plated.	Brass: Pins, Nickel Plated. Tabs, Tin Plated.
Approvals:			*Pending	
Accessories / Notes:		P.No.11328 (See Page 40).	Note: Standard without cover. With cover add /C.	P.No.11328 (See Page 40).
Mating Connectors:		PX0587, PX0587/SE, PX0588,	PX0587, PX0587/SE, PX0588,	PX0587, PX0587/SE, PX0588,

EN60 320 (BS4491 Standard Sheet C14 Class I) Cold Condition

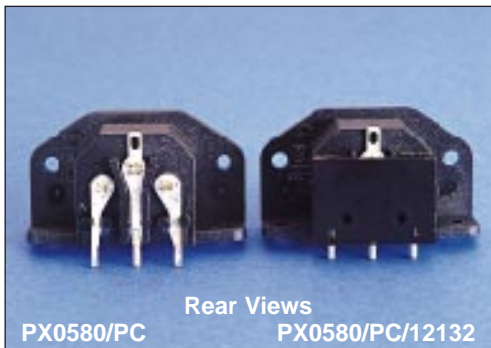
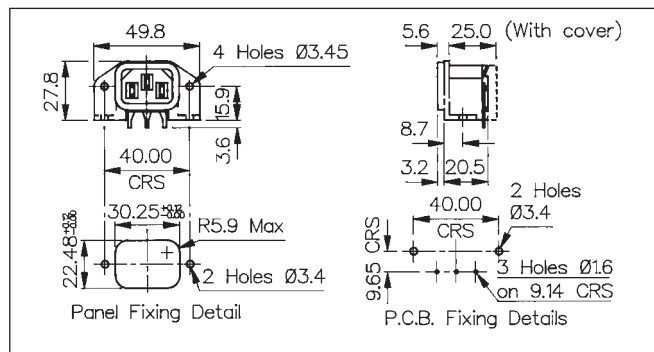
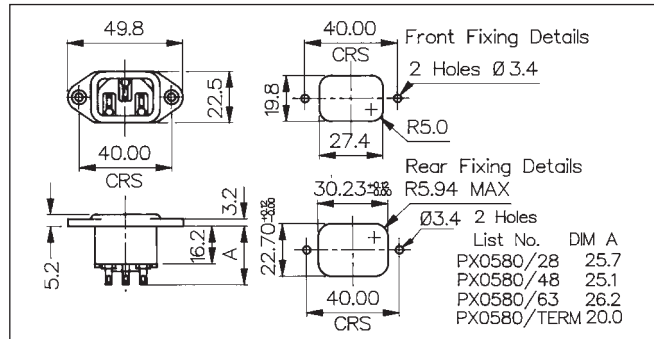

CONNECTORS



Data	List No.	PX0580/Termination	PX0580/PC
Fixing:		Flange.	P.C.B./Flange.
Terminations:		/28 (2.8mm solder), /48 (4.8mm tab), /63 (6.3mm tab), /TERM (screw).	P.C. Spills.
Max. Rating:		10A, 250V a.c. (UL & CSA 15A 250V a.c.)	10A, 250V a.c. (UL & CSA 15A 250V a.c.)
Contact Resistance:		<10mΩ.	<10mΩ.
Insulation Resistance:		>10 ³ MΩ.	>10 ³ MΩ.
A.C. Breakdown:		Pole-Pole 5kV. Poles-Panel 10kV.	Pole-Pole 5.4kV. Poles-Panel 10kV.
Operating Temp. Range:		-40°C to + 70°C.	-40°C to + 70°C.
Max. Pin Temp.:		+70°C.	+70°C.
Mouldings:		Nylon, Flammability Rating UL.94V-O.	Nylon, Flammability Rating UL.94V-O.
Contacts:		Brass: Pins, Nickel Plated. Tabs, Tin Plated. Screw Terms, Nickel Plated.	Brass: Pins, Nickel Plated. Spills, Tin Plated.
Approvals:			
Accessories / Notes:		P.No.11328. KT0006 (PX0587 & PZ0100 only) (See Page 40).	Note: Standard without cover. With cover add /12132.
Mating Connectors:		PX0587, PX0587/SE, PX0588,	PX0587, PX0587/SE, PX0588,



IEC Power Inlets

EN60 320 (BS4491 Standard Sheet C14 Class I) Cold Condition

CONNECTORS

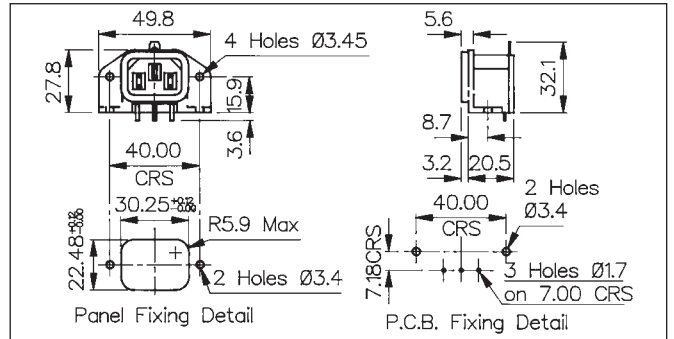

Certificate No. FM12622

Data	List No.	PX0580/PC/7		
Fixing:		P.C.B./Flange.		
Terminations:		P.C. Spills.		
Max. Rating:		10A. 250V a.c. (UL & CSA 15A 250V a.c.).		
Contact Resistance:		<10mΩ.		
Insulation Resistance:		>10 ³ MΩ.		
A.C. Breakdown:		Pole-Pole 4kV. Poles-Panel 6kV.		
Operating Temp. Range:		-40°C to + 70°C.		
Max. Pin Temp.:		+70°C.		
Mouldings:		Nylon, Flammability Rating UL.94V-O.		
Contacts:		Brass: Pins, Nickel Plated. Spills, Tin Plated.		
Approvals:				
Accessories / Notes:		Note: Standard with cover. Without cover add LC.		
Mating Connectors:		PX0587, PX0587/SE, PX0588,		

EN60 320 (BS4491 Standard Sheet C18 Class II) Cold Condition

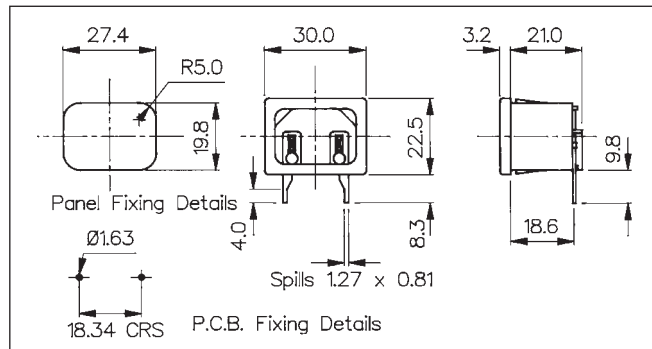
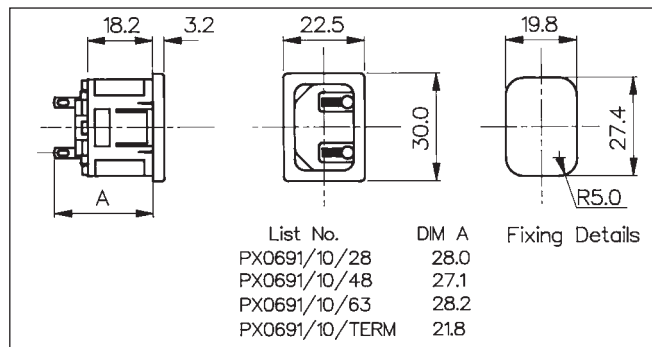
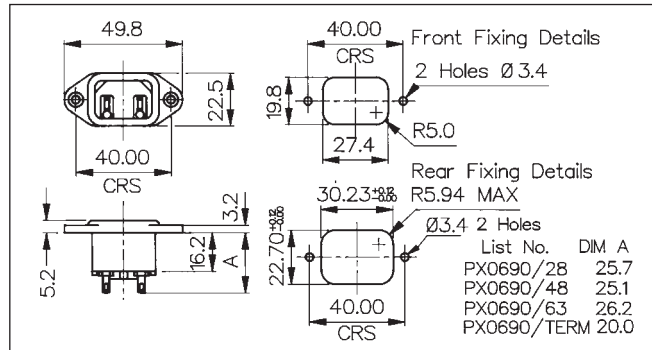

CONNECTORS



Data	List No.	PX0690/Termination	PX0691/Panel/Termination	PX0691/Panel/PC
Fixing (Panel):		Flange.	Push-fit. /10 (1mm), /15 (1.5mm), /20 (2mm), /30 (3mm).	Push-fit. /10 (1mm), /15 (1.5mm), /20 (2mm), /30 (3mm).
Terminations:		/28 (2.8mm solder), /48 (4.8mm tab), /63 (6.3mm tab), /TERM (screw).	/28 (2.8mm solder), /48 (4.8mm tab), /63 (6.3mm tab), /TERM (screw).	PC Spills
Max. Rating:		10A. 250V a.c. (UL & CSA 15A 250V a.c.).	10A. 250V a.c. (UL & CSA 15A 250V a.c.).	10A. 250V a.c. (UL & CSA 15A 250V a.c.).
Contact Resistance:		<10mΩ.	<10mΩ.	<10mΩ.
Insulation Resistance:		>10 ³ MΩ.	>10 ³ MΩ.	>10 ³ MΩ.
A.C. Breakdown:		Pole-Pole 5kV. Poles-Panel 10kV.	Pole-Pole 5kV. Poles-Panel 5.4kV.	Pole-Pole 5kV. Poles-Panel 5.4kV.
Operating Temp. Range:		-40°C to + 70°C.	-40°C to + 70°C.	-40°C to + 70°C.
Max. Pin Temp.:		+70°C.	+70°C.	+70°C.
Mouldings:		Nylon, Flammability Rating UL 94V-O.	Nylon, Flammability Rating UL 94V-O.	Nylon, Flammability Rating UL 94V-O.
Contacts:		Brass: Pins, Nickel Plated. Tabs, Tin Plated. Screw Terms, Nickel Plated.	Brass: Pins, Nickel Plated. Tabs, Tin Plated. Screw Terms, Nickel Plated.	Brass: Pins, Nickel Plated. Spills, Tin Plated.
Approvals:				
Accessories / Notes:		P.No.11328. (See Page 40).	P.No.11328. (See Page 40).	Note: Standard without Cover With Cover add /C.
Mating Connectors:				



IEC Power Inlets Fused

EN60 320 (BS4491 Standard Sheet C14 Class I) Cold Condition

CONNECTORS

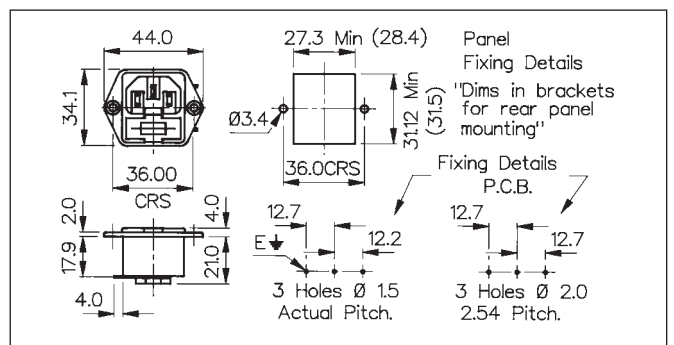
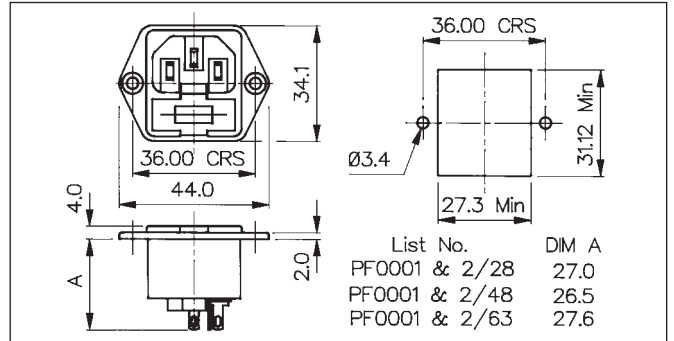
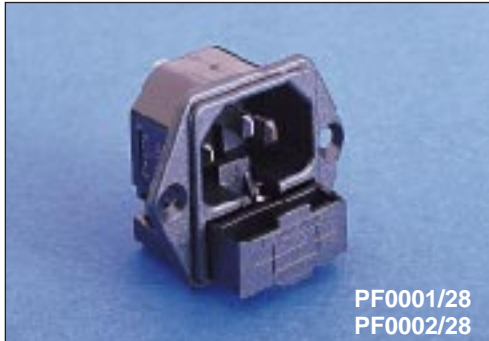

Data	List No.	PF0001/Termination	PF0001/PC	PF0002/Termination
Fixing:		Flange.	P.C.B/Flange.	Flange.
Terminations:		/28 (2.8mm solder), /48 (4.8mm tab), /63 (6.3mm tab).	P.C. Spills.	/28 (2.8mm solder), /48 (4.8mm tab), /63 (6.3mm tab).
Max. Rating:		10A. 250V a.c.	10A. 250V a.c.	10A. 250V a.c.
Contact Resistance:		<10mΩ. (<15 mΩ including Fuseholder).	<10mΩ. (<15 mΩ including Fuseholder).	<10mΩ. (<15 mΩ including Fuseholder).
Insulation Resistance:		>10 ³ MΩ.	>10 ³ MΩ.	>10 ³ MΩ.
A.C. Breakdown:		Pole-Pole 5.5kV. Poles-Panel 4kV.	Pole-Pole 5.5kV. Poles-Panel 4kV.	Pole-Pole 5.5kV. Poles-Panel 4kV.
Operating Temp. Range:		-40°C to + 70°C.	-40°C to + 70°C.	-40°C to + 70°C.
Max. Pin Temp.:		+70°C.	+70°C.	+70°C.
Mouldings:		Nylon, Flammability Rating UL.94V-O.	Nylon, Flammability Rating UL.94V-O.	Nylon, Flammability Rating UL.94V-O.
Contacts:		Brass: Pins, Nickel Plated. Tabs, Tin Plated.	Brass: Pins, Nickel Plated. Spills, Tin Plated.	Brass: Pins, Nickel Plated. Tabs: Tin Plated.
Approvals:				
Accessories / Notes:		P.No. 11987, KT0009 (See Page 40).	KT0009 (front of panel mounting only). (See Page 40).	P.No. 11987, KT0009 (See Page 40). (Note: Fuse contact isolated)
Mating Connectors:		PX0587, PX0587/SE, PX0588,	PX0587, PX0587/SE, PX0588,	PX0587, PX0587/SE, PX0588,

IEC Power Inlets Fused



EN60 320 (BS4491 Standard Sheet C14 Class I) Cold Condition

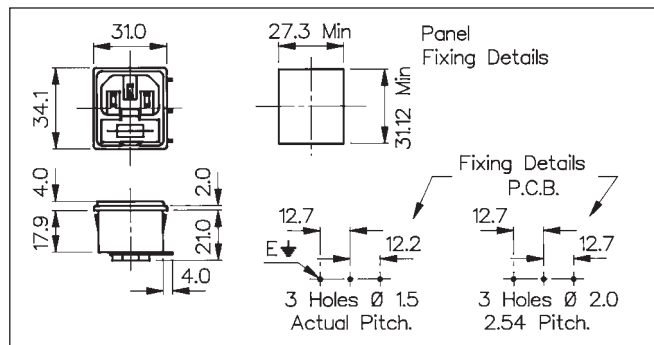
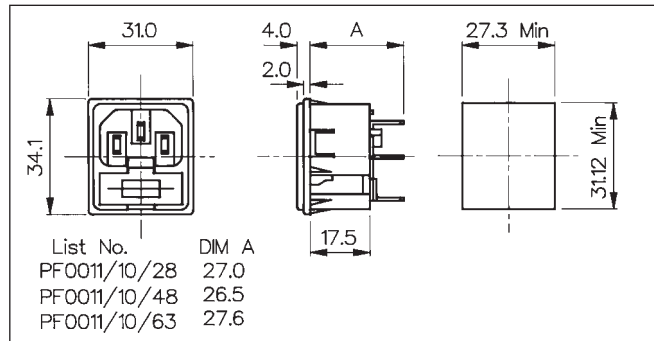
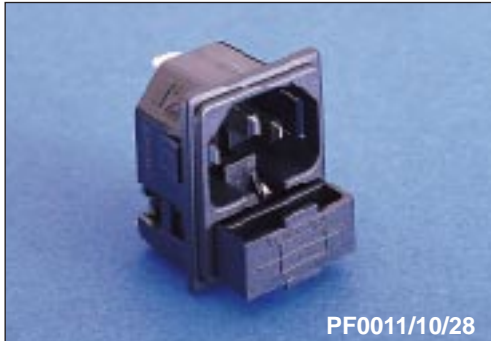

CONNECTORS



Data	List No.	PF0011/Panel/Termination	PF0011/Panel/PC	
Fixing (Panel):		Push-fit. /10 (1mm), /15 (1.5mm),/20 (2mm),/30 (3.0mm).	PCB/Push-fit., /10 (1mm), /15 (1.5mm),/20 (2mm),/30 (3mm).	
Terminations:		/28 (2.8mm solder),4.8 (4.8mm tab), /63 (6.3mm tab).	P.C. Spills.	
Max. Rating:		10A. 250V a.c.	10A. 250V a.c.	
Contact Resistance:		<10mΩ.(<15 mΩ including Fuseholder).	<10mΩ.(<15 mΩ including Fuseholder).	
Insulation Resistance:		>10 ³ MΩ.	>10 ³ MΩ.	
A.C. Breakdown:		Pole-Pole 5.5kV. Poles-Panel 4kV.	Pole-Pole 5.5kV. Poles-Panel 4kV.	
Operating Temp. Range:		-40°C to + 70°C.	-40°C to + 70°C.	
Max. Pin Temp.:		+70°C.	+70°C.	
Mouldings:		Nylon, Flammability Rating UL.94V-O.	Nylon, Flammability Rating UL.94V-O.	
Contacts:		Brass: Pins, Nickel Plated. Tabs, Tin Plated.	Brass: Pins, Nickel Plated. Spills, Tin Plated.	
Approvals:				
Accessories:		P.No.11987 (See Page 40).		
Mating Connectors:		PX0587, PX0587/SE, PX0588,	PX0587, PX0587/SE, PX0588,	



IEC Power Inlets Fused

EN60 320 (BS4491 Standard Sheet C18 Class II) Cold Condition

CONNECTORS

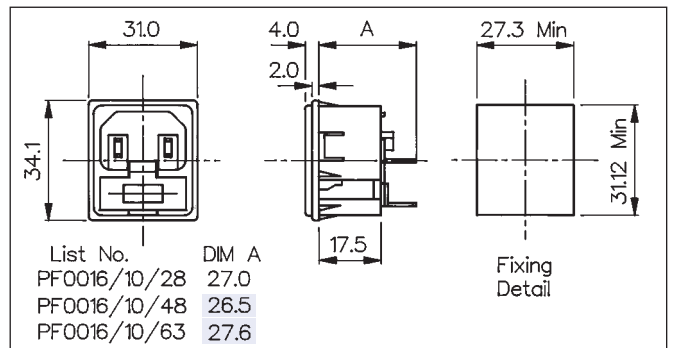
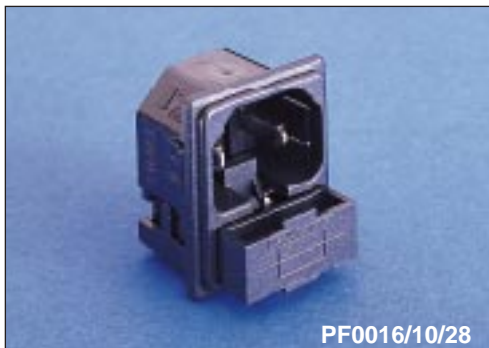
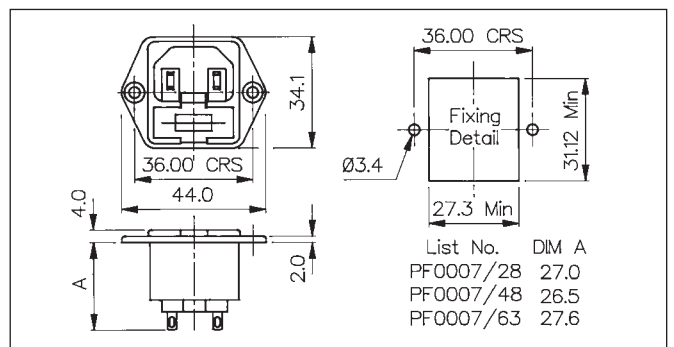
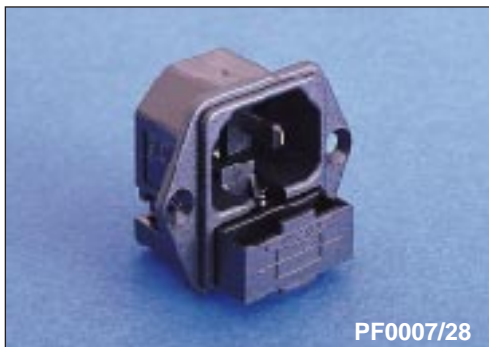
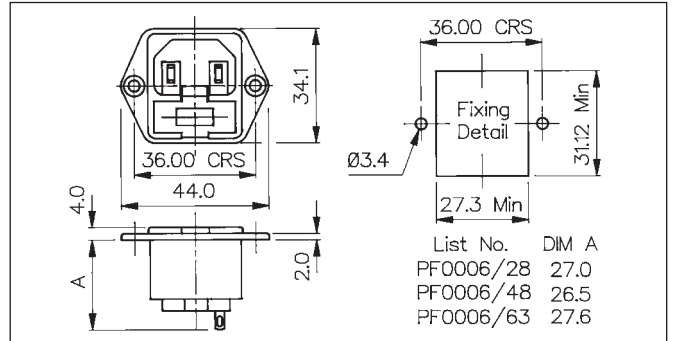
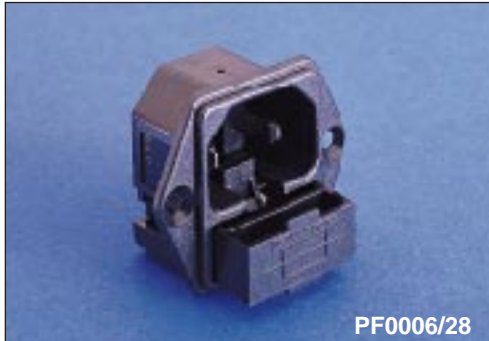

Certificate No. FM1282

Data	List No.	PF0006/Termination	PF0007/Termination	PF0016/Panel/Termination
Fixing (Panel):		Flange.	Flange.	Push-fit. /10 (1mm), /15 (1.5mm), /20 (2mm), /30 (3mm).
Terminations:		/28 (2.8mm solder), /48 (4.8mm tab), /63 (6.3mm tab).	/28 (2.8mm solder), /63 (6.3mm tab).	/28 (2.8mm solder), 4.8 (4.8mm tab), /63 (6.3mm tab).
Max. Rating:		10A. 250V a.c.	10A. 250V a.c.	10A. 250V a.c.
Contact Resistance:		<10mΩ. (<15 mΩ including Fuseholder).	<10mΩ. (<15 mΩ including Fuseholder).	<10mΩ. (<15 mΩ including Fuseholder).
Insulation Resistance:		>10 ³ MΩ.	>10 ³ MΩ.	>10 ³ MΩ.
A.C. Breakdown:		Pole-Pole 5.5kV. Poles-Panel 4kV.	Pole-Pole 5.5kV. Poles-Panel 4kV.	Pole-Pole 5.5kV. Poles-Panel 4kV.
Operating Temp. Range:		- 40°C to + 70°C.	- 40°C to + 70°C.	- 40°C to + 70°C.
Max. Pin Temp.:		+70°C.	+70°C.	+70°C.
Mouldings:		Nylon, Flammability Rating UL.94V-O.	Nylon, Flammability Rating UL.94V-O.	Nylon, Flammability Rating UL.94V-O.
Contacts:		Brass: Pins, Nickel Plated. Tabs, Tin Plated.	Brass: Pins, Nickel Plated. Tabs, Tin Plated.	Brass: Pins, Nickel Plated. Tabs, Tin Plated.
Approvals:				
Accessories / Notes:		P.No. 11987. (See Page 40).	P.No. 11987. (See Page 40). (fuse contacts isolated).	P.No. 11987. (See Page 40).
Mating Connectors:				

IEC Power Inlets Fused



EN60 320 (BS4491 Standard Sheet C14 Class I) Cold Condition (Fused, Twin)

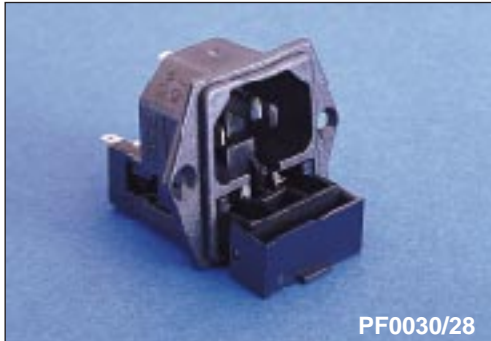

PF0030/28

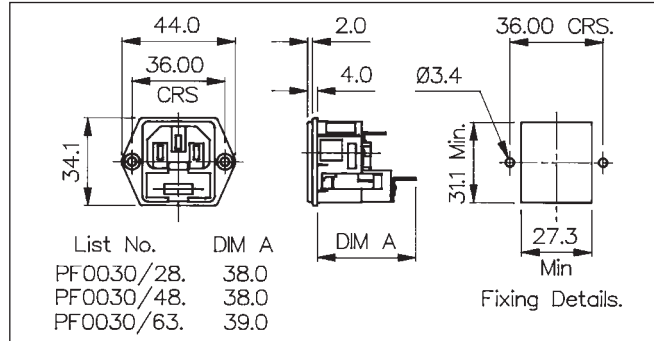

PF0030/PC

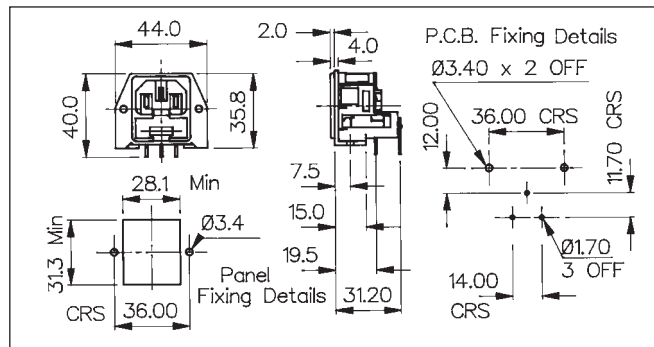

PF0033/10/28

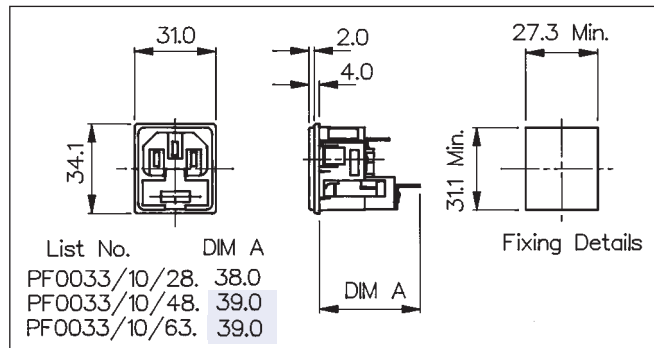

CONNECTORS



Data	List No.	PF0030/Termination	PF0030/PC	PF0033/Panel/Termination
Fixing (Panel):		Flange.	P.C.B/Flange.	Push-fit. /10 (1mm), /15 (1.5mm), /20 (2mm), /30 (3mm).
Terminations:		/28 (2.8mm solder),/48 (4.8mm tabs), /63 (6.3mm tabs).	P.C. Spills.	/28 (2.8mm solder),/48 (4.8mm tabs), /63 (6.3mm tabs).
Max. Rating:		10A. 250V a.c.	10A. 250V a.c.	10A. 250V a.c.
Contact Resistance:		<15mΩ.(per pole).	<15mΩ.(per pole).	<15mΩ.(per pole).
Insulation Resistance:		>10 ⁴ MΩ.	>10 ⁴ MΩ.	>10 ⁴ MΩ.
A.C. Breakdown:		Pole-Pole 6kV. Poles-Panel 5kV.	Pole-Pole 6kV. Poles-Panel 5kV.	Pole-Pole 6kV. Poles-Panel 5kV.
Max. Dissipation Per Fuse:		2.5W.	2.5W.	2.5W.
Operating Temp. Range:		-20°C to + 70°C.	-20°C to + 70°C.	-20°C to + 70°C.
Max. Pin Temp.:		+ 70°C.	+ 70°C.	+ 70°C.
Mouldings:		Nylon, Flammability Rating UL.94V-O.	Nylon, Flammability Rating UL.94V-O.	Nylon, Flammability Rating UL.94V-O.
Contacts:		Brass: Pins, Nickel Plated.Tabs, Tin Plated.	Brass: Pins, Nickel Plated.Tabs, Tin Plated.	Brass: Pins, Nickel Plated.Tabs, Tin Plated.
Approvals:				
Accessories:		KT0009 (See Page 40).		
Mating Connectors:		PX0587, PX0587/SE, PX0588,	PX0587, PX0587/SE, PX0588,	PX0587, PX0587/SE, PX0588,



IEC Power Connectors

EN60 320 (BS4491 Standard Sheet C13 Class I) Rewirable Cold Condition

CONNECTORS



PX0587

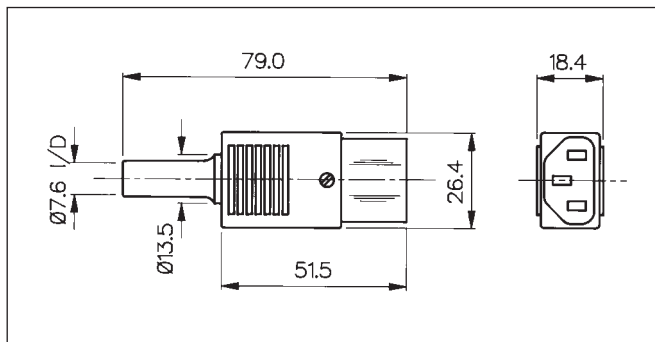

PX0587/SE

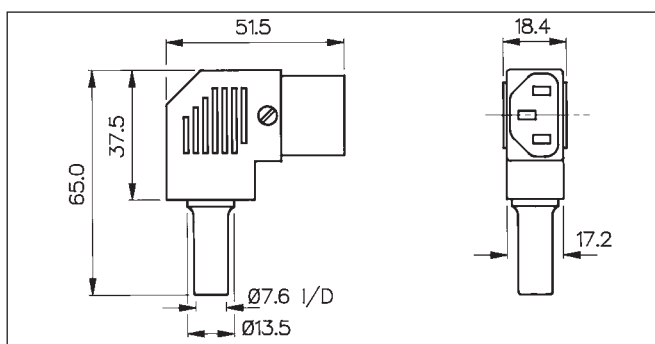

PX0588

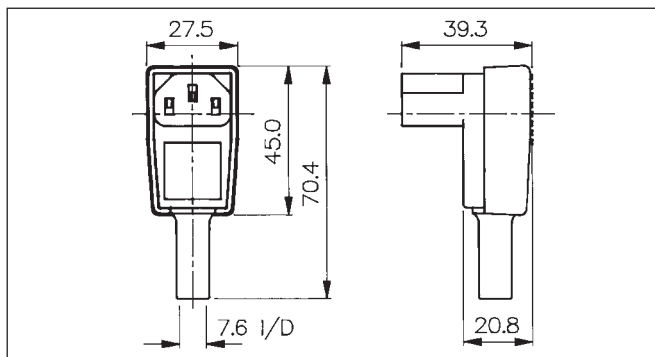

Certificate No. FM12622

Data	List No.	PX0587	PX0587/SE	PX0588
Terminations:		Screw Terminals.	Screw Terminals.	Screw Terminals.
Max. Rating:		10A. 250V a.c.	10A. 250V a.c.	10A. 250V a.c.
Contact Resistance:		<10mΩ.	<10mΩ.	<10mΩ.
Insulation Resistance:		>10 ³ MΩ.	>10 ³ MΩ.	>10 ³ MΩ.
A.C. Breakdown:		Pole-Pole 4.5kV. Poles-Accessible Parts 4kV	Pole-Pole 4.5kV. Poles-Accessible Parts 4kV	Pole-Pole 5kV. Poles-Accessible Parts 3.5kV
Operating Temp. Range:		-40°C to +70°C.	-40°C to +70°C.	-40°C to +70°C.
Withdrawal Force:		10N (Min). 50N (Max).	10N (Min). 50N (Max).	10N (Min). 50N (Max).
Mouldings:		Nylon, Flammability Rating UL.94V-O.	Nylon, Flammability Rating UL.94V-O.	Nylon, Flammability Rating UL.94V-O.
Contacts:		Brass: Clean.	Brass: Clean.	Brass, Nickel Plated.
Approvals:				
Accessories:				
Mates with:		PX0575, PX0579, PX0580, PF0001,	PX0575, PX0579, PX0580, PF0001,	PX0575, PX0579, PX0580, PF0001,

IEC Power Inlets & Connectors



EN60 320 (BS4491 Standard Sheet C16 Class I) & (BS4491 Standard Sheet C15 Class I) Hot Condition

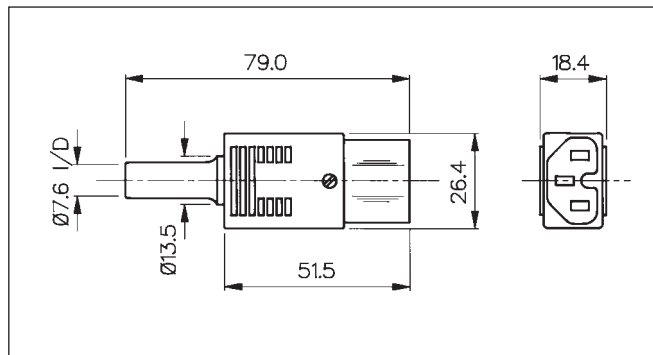
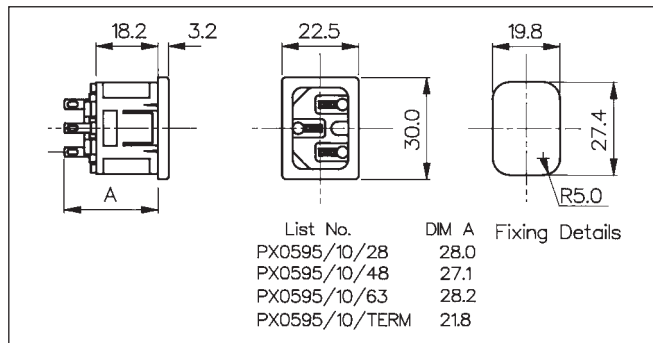
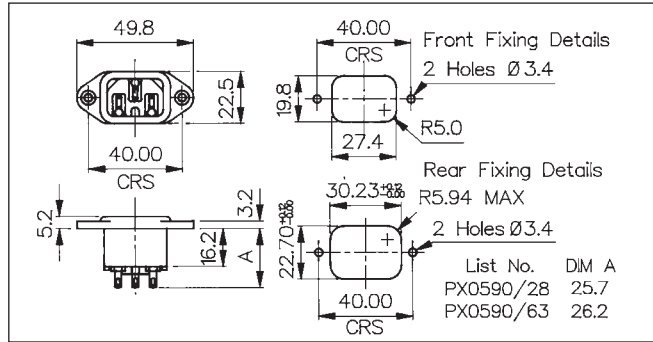

CONNECTORS



Data	List No.	PX0590/Termination	PX0595/Panel/Termination	PX0597
Fixing (Panel):		Flange.	Push-fit./10 (1mm) /15 (1.5mm),/20 (2mm),/30 (3mm).	
Terminations:		/28 (2.8mm solder),/63 (6.3mm tab).	/28 (2.8mm solder),/48 (4.8mm tab), /63 (6.3mm tab),/TERM (screw).	Screw Terminals
Max. Rating:		10A. 250V a.c. (U.L & CSA 15A 250v a.c).	10A. 250V a.c. (U.L & CSA 15A 250v a.c).	10A. 250V a.c.
Contact Resistance:		<10mΩ.	<10mΩ.	<10mΩ.
Insulation Resistance:		>10 ³ MΩ.	>10 ³ MΩ.	>10 ³ MΩ.
A.C. Breakdown:		Pole-Pole 5kV. Poles-Panel 10kV.	Pole-Pole 5kV. Poles-Panel 5.4kV.	Pole- Pole 4.5kV. Poles- Accessable Parts 4kV.
Operating Temp. Range: Max. Pin Temp.:		-40°C to + 70°C. + 120°C.	-40°C to + 70°C. + 120°C.	-40°C to + 70°C.
Withdrawal Force:				10N (Min). 50N (Max).
Mouldings:		Nylon, Flammability Rating UL.94V-O.	Nylon, Flammability Rating UL.94V-O.	Nylon, Flammability Rating UL.94V-O.
Contacts:		Brass: Pins, Nickel Plated. Tabs, Tin Plated.	Brass: Pins, Nickel Plated. Tabs, Tin Plated.	Brass: Clean.
Approvals:				
Accessories:		P.No.11328, KT0006 (See Page 40).	P.No.11328 (See Page 40).	



IEC Outlets - 2 & 4 Way

CONNECTORS

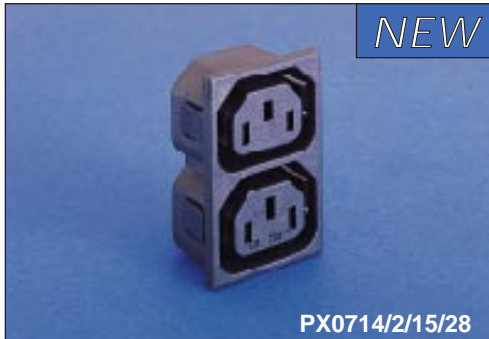

PX0714/2/15/28

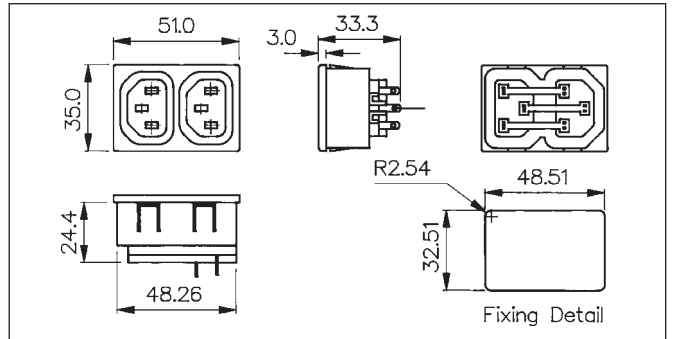

PX0714/4/15/28

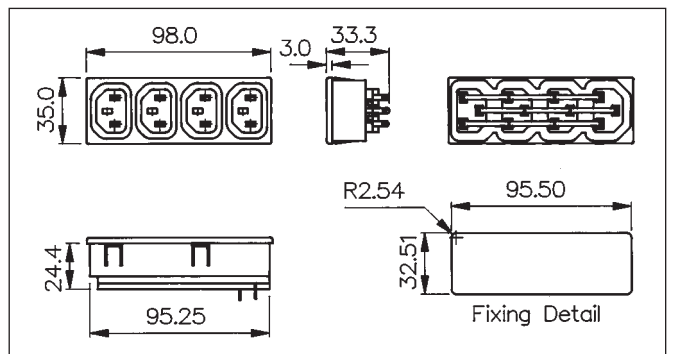

Certificate No. FM12622

Data	List No.	PX0714/2/15/28	PX0714/4/15/28
Fixing:		Push-fit /15 (1.5mm)	Push-fit 15 (1.5mm)
Terminations:		2.8mm solder	2.8mm solder
Max. Rating:		10A, 250V ac	10A, 250V ac
Operating Temp. Range:		-20 to +70°C	-20 to +70°C
Mouldings:		Nylon, Flammability Rating UL.94V-O.	Nylon, Flammability Rating UL.94V-O.
Contacts & Busbar:		Plated Copper Alloy	Plated Copper Alloy
Approvals:			
Mates with:		PX0685, PX0686, PX0686/SE,	PX0685, PX0686, PX0686/SE,



BS EN60 320 - 2 - 2 (Standard Sheet F Class I)

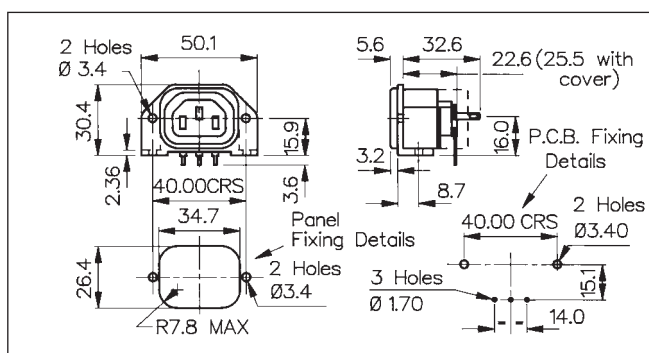
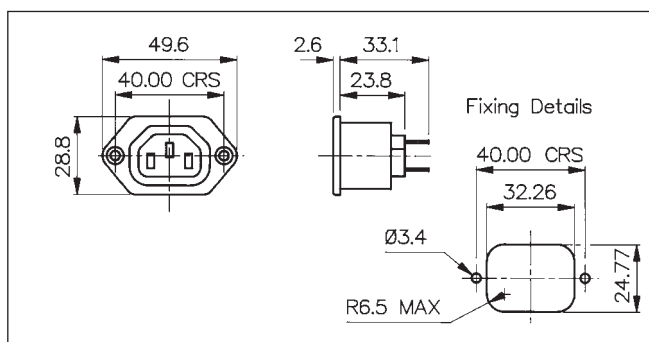

CONNECTORS



Data	List No.	PX0675/Termination	PX0675/PC
Fixing:		Flange.	P.C.B./Flange.
Terminations:		/28 (2.8mm solder),/63 (6.3mm tab).	P.C. Spills.
Max. Rating:		10A. 250V a.c. (UL & CSA 15A 250V a.c.)	10A. 250V a.c. (UL & CSA 15A 250V a.c.)
Contact Resistance:		<10mΩ.	<10mΩ.
Insulation Resistance:		>10 ⁴ MΩ.	>10 ⁴ MΩ.
A.C. Breakdown:		Pole-Pole 7kV. Poles-Panel 9kV.	Pole-Pole 4kV. Poles-Panel 9kV.
Operating Temp. Range:		-40°C to +70°C.	-40°C to +70°C.
Mouldings:		Nylon, Flammability Rating UL 94V-O.	Nylon, Flammability Rating UL 94V-O.
Contacts:		Brass: Tin Plated.	Brass: Tin Plated.
Approvals:			
Accessories / Notes:		P.No12075, KT0006 (See Page 40).	Note: Standard without cover. With cover add /12599 to List No.
Mates with:		PX0685, PX0686, PX0686/SE,	PX0685, PX0686, PX0686/SE,



IEC Power Outlets

BS EN60 320 - 2 - 2 (Standard Sheet F Class I)

CONNECTORS

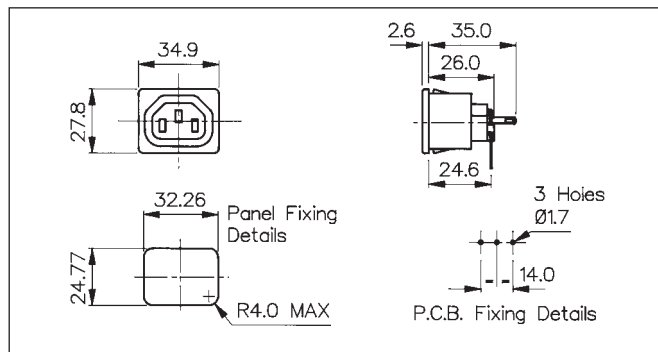
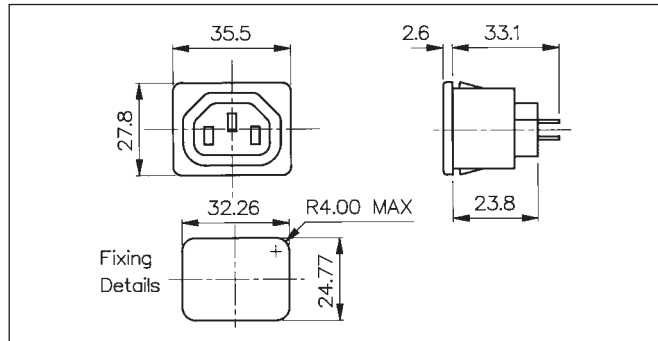

Certificate No. FM12622

Data	List No.	PX0695/Panel/Termination	PX0695/Panel/PC
Fixing (Panel):		Push-fit. /10 (1mm), /15 (1.5mm), /20 (2mm), /30 (3mm).	Push-fit. /10 (1mm), /15 (1.5mm), /20 (2mm), /30 (3mm).
Terminations:		/28 (2.8mm solder), /63 (6.3mm tab).	P.C. Spills.
Max. Rating:		10A. 250V a.c. (UL & CSA 15A 250V a.c.)	10A. 250V a.c. (UL & CSA 15A 250V a.c.)
Contact Resistance:		<10mΩ.	<10mΩ.
Insulation Resistance:		>10 ⁴ MΩ.	>10 ⁴ MΩ.
A.C. Breakdown:		Pole-Pole 7kV. Poles-Panel 9kV.	Pole-Pole 4kV. Poles-Panel 9kV.
Operating Temp. Range:		-40°C to +70°C.	-40°C to +70°C.
Mouldings:		Nylon, Flammability Rating UL.94V-O.	Nylon, Flammability Rating UL.94V-O.
Contacts:		Brass: Tin Plated.	Brass: Tin Plated.
Approvals:			
Accessories:		P.No12075 (See Page 40).	
Mating Connectors:		PX0685, PX0686, PX0686/SE,	PX0685, PX0686, PX0686/SE,

IEC Power Outlets (Shuttered)



BS EN60 320 - 2 - 2 (Standard Sheet F Class I)



PX0783/10/28

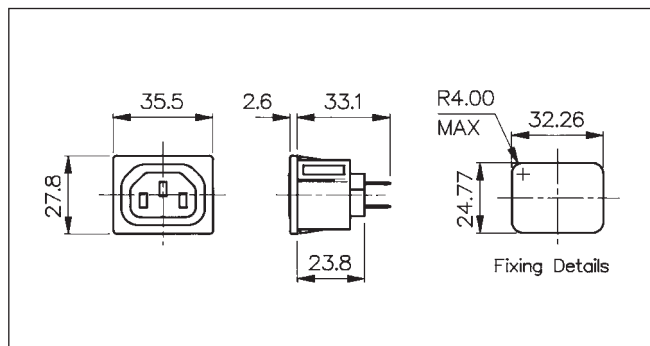

PX0793/28

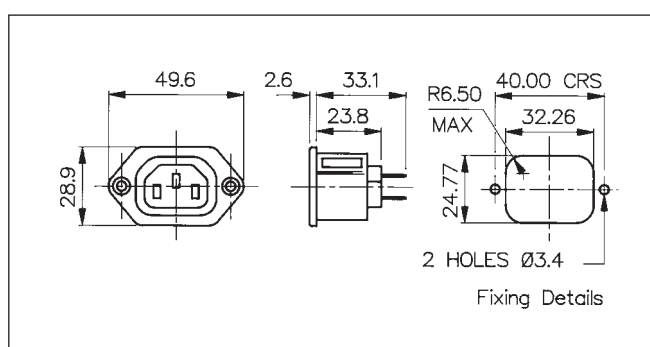

CONNECTORS



Data	List No.	PX0783/Panel/Termination	PX0793/Termination	
Fixing (Panel):		Push-fit. /10 (1mm), /15 (1.5mm), /20 (2mm), /30 (3mm).	Flange.	
Terminations:		/28 (2.8mm solder), /63 (6.3mm tab).	/28 (2.8mm solder), /63 (6.3mm tab).	
Max. Rating:		10A. 250V a.c. (UL & CSA 15A 250V a.c.)	10A. 250V a.c. (UL & CSA 15A 250V a.c.)	
Contact Resistance:		<10mΩ.	<10mΩ.	
Insulation Resistance:		>10 ⁴ MΩ.	>10 ⁴ MΩ.	
A.C. Breakdown:		Pole-Pole 7kV. Poles-Panel 9kV.	Pole-Pole 7kV. Poles-Panel 9kV.	
Operating Temp. Range:		-40°C to +70°C.	-40°C to +70°C.	
Mouldings:		Nylon, Flammability Rating UL.94V-O.	Nylon, Flammability Rating UL.94V-O.	
Contacts:		Brass: Tin Plated.	Brass: Tin Plated.	
Approvals:				
Accessories:		P.No12075 (See Page 40).	P.No12075, KT0006 (See Page 40).	
Mates with:		PX0685, PX0686, PX0686/SE,	PX0685, PX0686, PX0686/SE,	



IEC Power Outlets

BS EN60 320 - 2 - 2 (Standard Sheet H Class II)

CONNECTORS

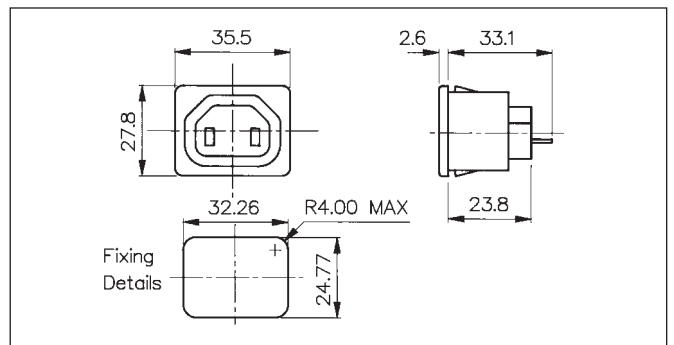
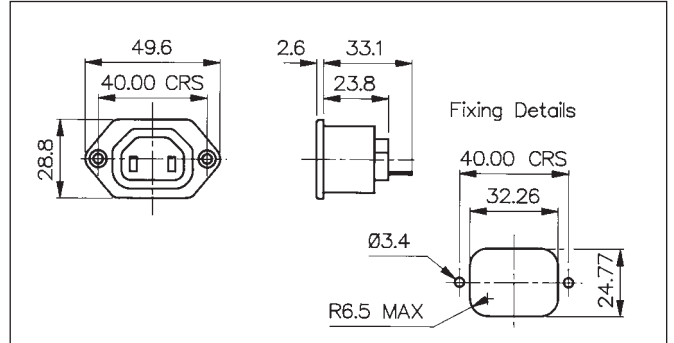
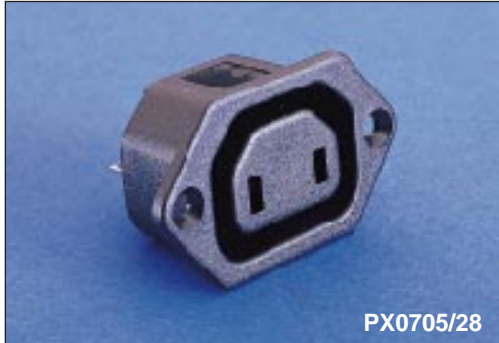

Certificate No. FM12022

Data	List No.	PX0705/Termination	PX0725/Panel/Termination
Fixing (Panel):		Flange.	Push-fit. /10 (1mm), /15 (1.5mm), /20 (2mm), /30 (3mm).
Terminations:		/28 (2.8mm solder), /63 (6.3mm tab).	/28 (2.8mm solder), /63 (6.3mm tab).
Max. Rating:		10A. 250V a.c. (UL & CSA 15A 250V a.c.)	10A. 250V a.c. (UL & CSA 15A 250V a.c.)
Contact Resistance:		<10mΩ.	<10mΩ.
Insulation Resistance:		>10 ⁴ MΩ.	>10 ⁴ MΩ.
A.C. Breakdown:		Pole-Pole 4kV. Poles-Panel 9kV.	Pole-Pole 7kV. Poles-Panel 9kV.
Operating Temp. Range:		-40°C to +70°C.	-40°C to +70°C.
Mouldings:		Nylon, Flammability Rating UL.94V-O.	Nylon, Flammability Rating UL.94V-O.
Contacts:		Brass: Tin Plated.	Brass: Tin Plated.
Approvals:			
Accessories:		P.No12075 (See Page 40).	P.No12075 (See Page 40).

BS EN60 320 - 2 - 2 (Standard Sheet E Class I) Rewirable



PX0685

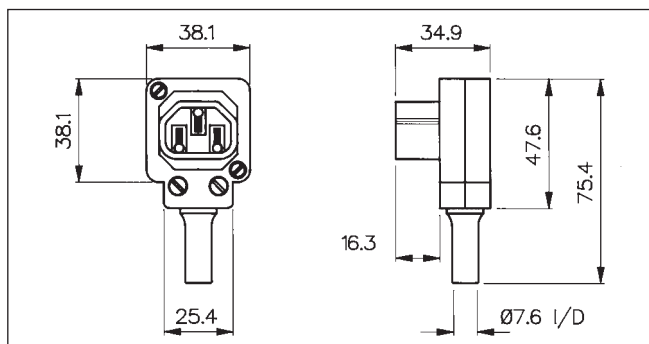

PX0686

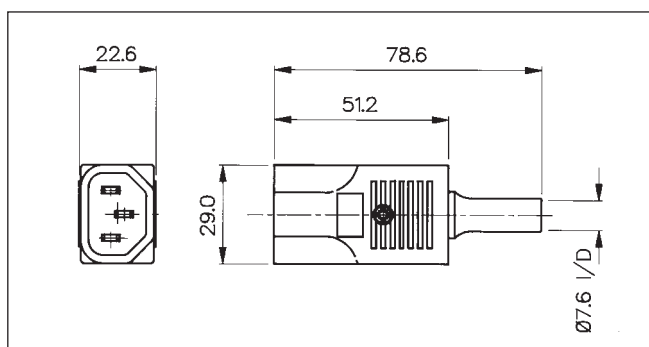

PX0686/SE

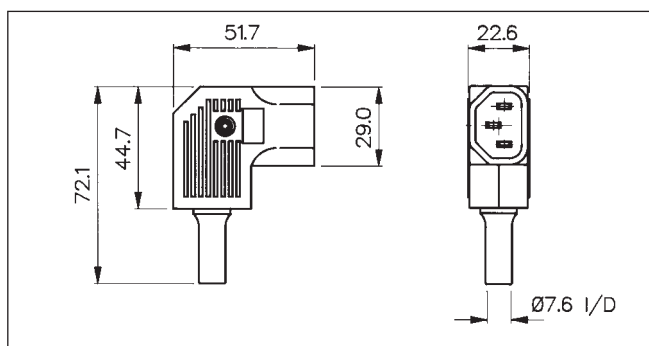

Data	List No.	PX0685	PX0686	PX0686/SE
Terminations:		Screw terminals.	Screw terminals.	Screw terminals.
Max. Rating:		10A. 250V a.c.	10A. 250V a.c.	10A. 250V a.c.
Contact Resistance:		<10mΩ.	<10mΩ.	<10mΩ.
Insulation Resistance:		>10 ⁴ MΩ.	>10 ⁴ MΩ.	>10 ⁴ MΩ.
A.C. Breakdown:		Pole-Pole 5.2kV. Poles-Accessible parts 6kV.	Pole-Pole 5kV Poles-Accessible parts 5kV.	Pole-Pole 5kV. Poles-Accessible parts 5kV.
Operating Temp. Range:		-40°C to +70°C.	-40°C to +70°C.	-40°C to +70°C.
Withdrawal Force:		10N (Min) 50N (Max).	10N (Min) 50N (Max).	10N (Min) 50N (Max).
Mouldings:		Nylon, Flammability Rating UL.94V-O.	Nylon, Flammability Rating UL.94V-O.	Nylon, Flammability Rating UL.94V-O.
Contacts:		Brass: Nickel Plated.	Brass: Nickel Plated.	Brass: Nickel Plated.
Approvals:				
Accessories / Notes:		Unique octagon module allows choice of 4 cable positions.		
Mates with:		PX0675. PX0695. PX0783. PX0793.	PX0675, PX0695, PX0783, PX0793,	PX0675, PX0695, PX0783, PX0793,

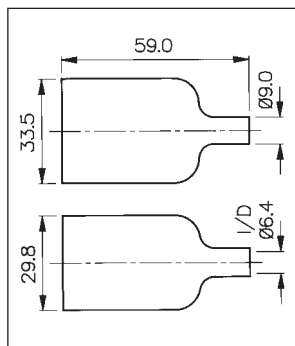
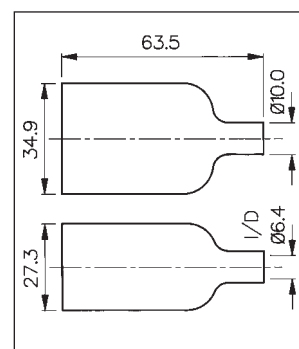
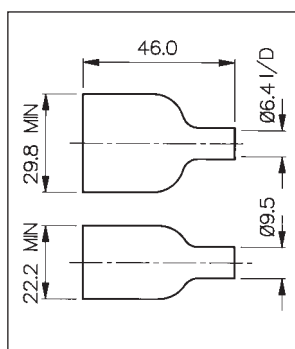
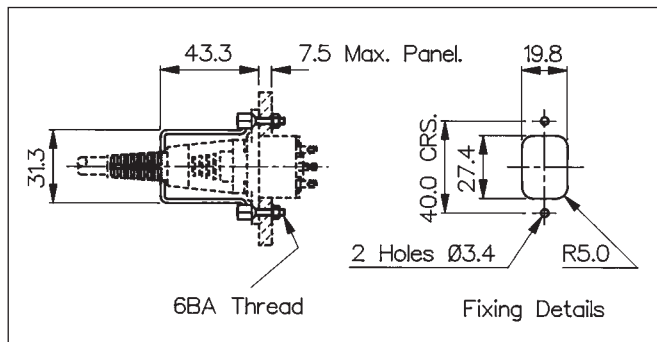

Data	List No.	KT0006, KT0009	PNo 11328	PNo 11987	PNo 12075
		Retaining Clips to prevent accidental removal of connector. KT0006 - PX0580, PX0590, PX0675, PX0793, PXS580, PXT580. KT0009 - PF0001, PF0001/PC, PF0002, PF0030.	Insulation boot - PX0575, PX0579, PX0580, PX0590, PX0595, PXS575, PXS579, PXS580, PXT575, PXT579, PXT580.	Insulation boot for PF range (except /PC versions and PF0030, PF0033).	Insulation boot - PX0675, PX0695, PX0783, PX0793 (except /PC versions)
Operating Temp. Range:			-20°C to +60°C	-20°C to +60°C	-20°C to +60°C
Max. Working Voltage:			250V a.c.	250V a.c.	250V a.c.
Flash Tested:			2kV a.c.	2kV a.c.	2kV a.c.
Material:		Clip: Stainless Steel, all other parts Brass, Nickel Plated	P.V.C	P.V.C.	P.V.C.

IEC Distribution Box/Panel



PXD301/050/01/1

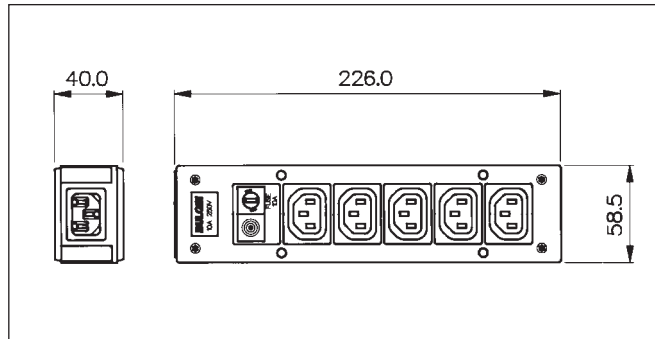

PXD100/050/01/1

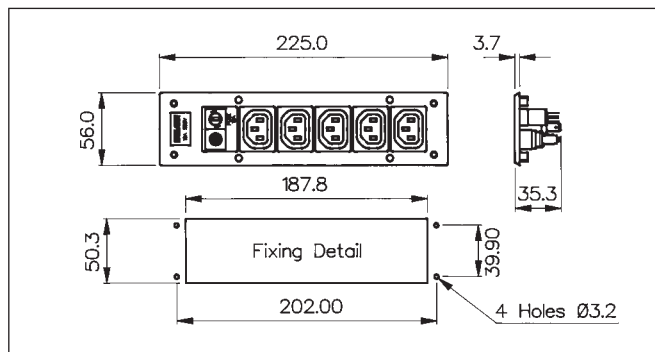

PXD303/050/01/1
PXD306/050/01/1

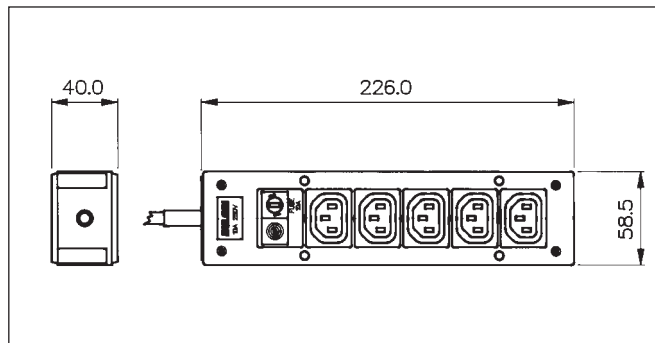

CONNECTORS



Data	
Mouldings:	Thermoplastic.
Contacts:	Outlets; Tin Plated Brass. Inlets; Nickel Plated Brass.
Voltage Rating:	250V a.c. 50/60Hz.
Current Rating:	10A.
Proof Voltage:	2kV.
Temp. Range:	-5°C to +60°C
Filter	
Max. Earth Leakage Current:	<0.35mA (at 250V, 50Hz).
Capacitor:	2 x 2.2nF (Y), 1 x 15nF (X)
Inductance:	2 x 0.35mH.
Fuses:	5 x 20mm, 10A

List No.	Inlet	Outlet	Neon Indicator	Fuse	Approvals
PXD100/050/01/1 (panel)	-	5 shuttered	1	1	Ⓢ
PXD301/050/01/1 (box)	1	5 shuttered	1	1	Ⓢ
PXD301/550/01/1 (box)	1	5 shuttered Filtered	1	1	Ⓢ
PXD303/050/01/1 (box)	2m cable with BS 1363 plug	5 shuttered	1	1	
PXD303/550/01/1 (box)	2m cable with BS 1363 plug	5 Shuttered Filtered	1	1	
PXD306/050/01/1 (box)	2m cable with CEE7 Sheet VII plug	5 shuttered	1	1	Ⓢ



IEC Distribution Box (Metal)

CONNECTORS

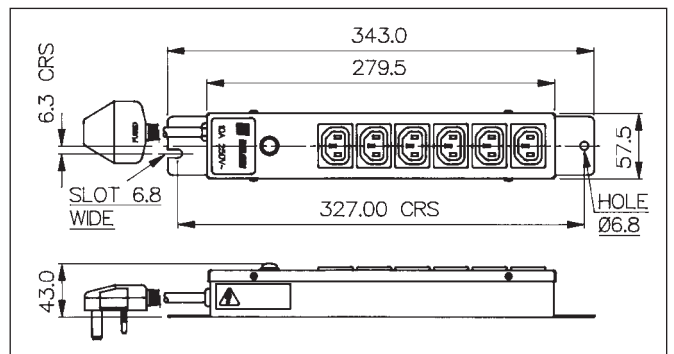
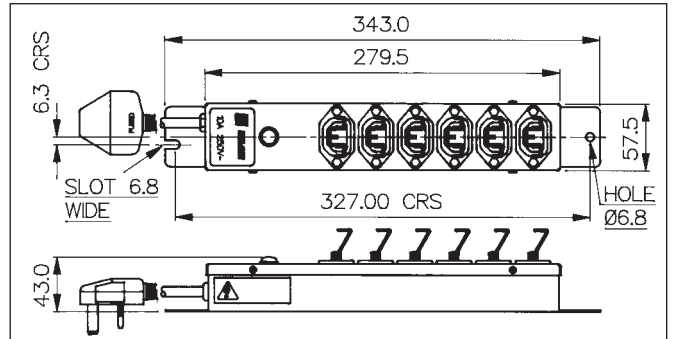

Certificate No. FM 12622

Data	
Case:	Steel, Light Grey Finish.
Mouldings:	Nylon, Flammability Rating UL94V-O.
Contacts:	Brass, Tin Plated.
Voltage Rating:	250V a.c.
Current Rating:	10A.
Proof Voltage:	2kV.
Temp. Range:	-5°C to +60°C
Fuse (In mains plug):	10A.

List No.	Version	Outlet	Neon Indicator	Power In
PMD503/01A/01/1	With Connector Retaining Clips	6 shuttered	1	2m cable with BS1363 plug
PMD503/02A/01/1	No Clips	6 shuttered	1	2m cable with BS1363 plug

IEC Distribution Box/Panel



PXD701/061/10/1

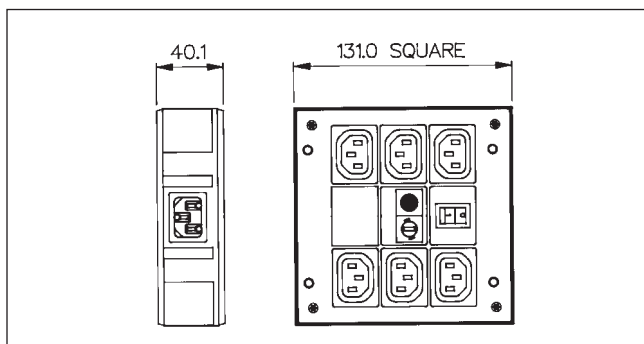

PXD500/061/10/1

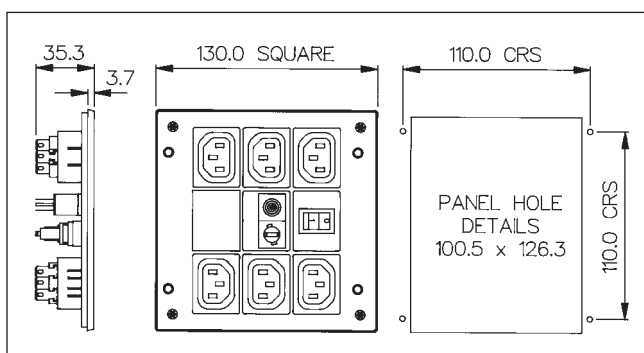

PXD703/061/10/1
PXD706/061/10/1

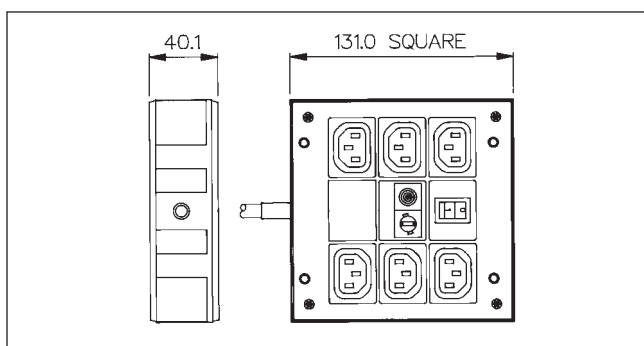

CONNECTORS



Data	
Mouldings:	Thermoplastic.
Contacts:	Outlets; Tin Plated Brass. Inlets; Nickel Plated Brass.
Voltage Rating:	250V a.c. 50/60Hz.
Current Rating:	10A.
Proof Voltage:	2kV.
Temp. Range:	-5°C to +60°C
Filter	
Max. Earth Leakage Current:	<0.35mA (at 250V 50Hz).
Capacitor:	2 x 2.2nF (Y), 1 x 15nF (X)
Inductance:	2 x 0.35mH.
Fuse:	5 x 20mm, 10A

List No.	Inlet	Outlet	Switch	Fuse	Neon Indicator
PXD500/061/10/1 (Panel)	-	6 shuttered	1	1	1
PXD701/061/10/1 (box)	1	6 shuttered	1	1	1
PXD701/561/10/1 (box)	1	6 shuttered Filtered	1	1	1
PXD703/061/10/1 (box)	2m cable with BS1363 plug	6 shuttered	1	1	1
PXD703/561/10/1 (box)	2m cable with BS1363 plug	6 shuttered Filtered	1	1	1
PXD706/061/10/1 (box)	2m cable with CEE7 Sheet VII plug	6 shuttered	1	1	1

Other versions available on request.



Notes

C
O
N
N
E
C
T
O
R
S



Certificate No. FM 12623