

# PBD 3545/1 Universal Sink Driver

## Description

PBD 3545/1 is a bipolar universal high-current highly-protected low side driver with transparent input and 2 A continuous-current sink capability. A high-level input activates the output.

The driver is equipped with extensive electrical protection, such as overcurrent protection and thermal protection, which makes the device virtually indestructible. Furthermore it can detect open circuit and short circuit to ground.

A special feature is the Error indicating output function pin which signals to the host system if the protection or the load check functions is activated.

Typical loads are solenoids, relays or resistive loads.

The PBD 3545/1 and PBD 3548/1 are complementary drivers and have similar data.

## Key Features

- 2 A continuous-output current
- Short circuit to  $V_{CC}$  protection
- Error signal to host system
- Open circuit detection
- Short circuit to ground detection
- Thermal protection
- Built-in protection diodes
- LS-TTL, CMOS, and supply voltage compatible input
- ESD protected
- 5-pin TO-220 package, or 28-lead power PLCC with lead-frame for heat-sinking through PC board copper.

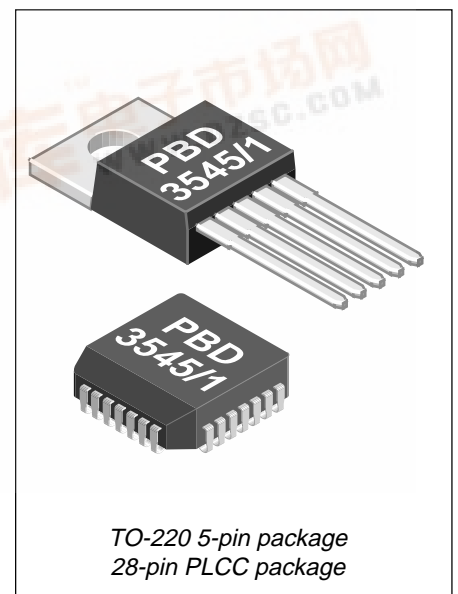
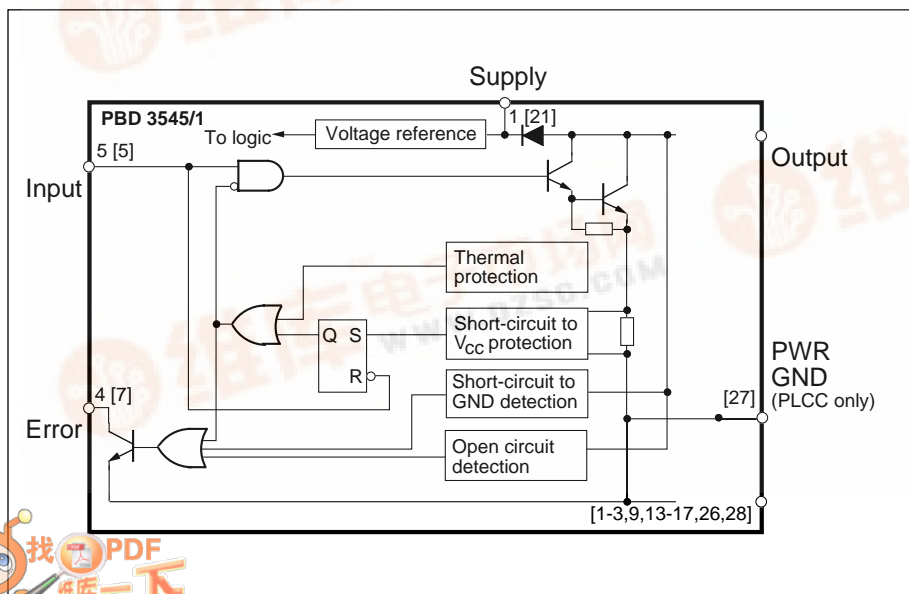
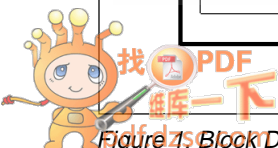

Figure 1: Block Diagram. Pin number in brackets refer to PLCC package.



### Maximum Ratings

Parameter	Pin no.	Symbol	Min	Max	Unit
<b>Voltage</b>					
Supply voltage	1 [21]	$V_{CC}$	0	45	V
Logic input voltage	5 [5]	$V_{IN}$	-0.3	$V_{CC}$	V
<b>Current</b>					
Logic input current	5 [5]	$I_{IN}$	-10		mA
Continuous DC Operation output current	2 [24]	$I_{OUT}$		2.0	A
Error output current	4 [7]	$I_{ERR}$		10	mA
<b>Temperature</b>					
Operating junction temperature (internally limited)		$T_J$		+140	°C
Storage temperature		$T_S$	-55	+150	°C
<b>Power Dissipation (Package Data)</b>					
Power dissipation at $T_{Case} = 85^{\circ}C$ , TO-220 package		$P_D$		11	W
Power dissipation at $T_{Case} = 85^{\circ}C$ , PLCC package		$P_D$		5	W
<b>ESD</b>					
ESD tolerance (Note 2)			2000		V

### Recommended Operating Conditions

Parameter	Symbol	Min	Typ	Max	Unit
Supply voltage	$V_{CC}$	4.75		40	V
Output current	$I_{OUT}$			2.0	A
Operating ambient temperature	$T_A$	-40		+85	°C
Error output current	$I_{Err}$		5	8	mA

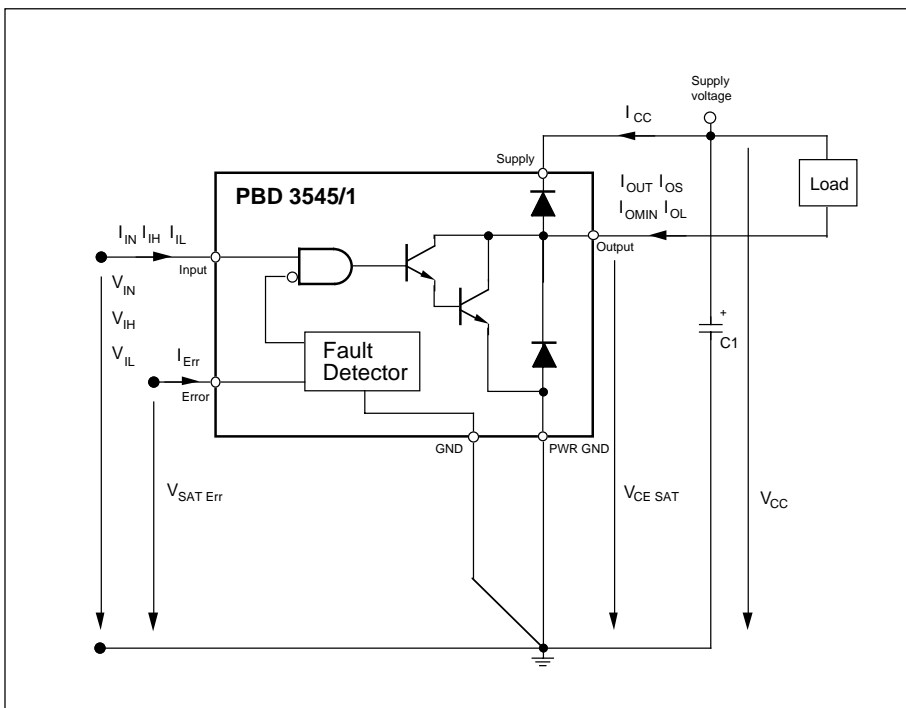

Figure 2. Definition of symbols.

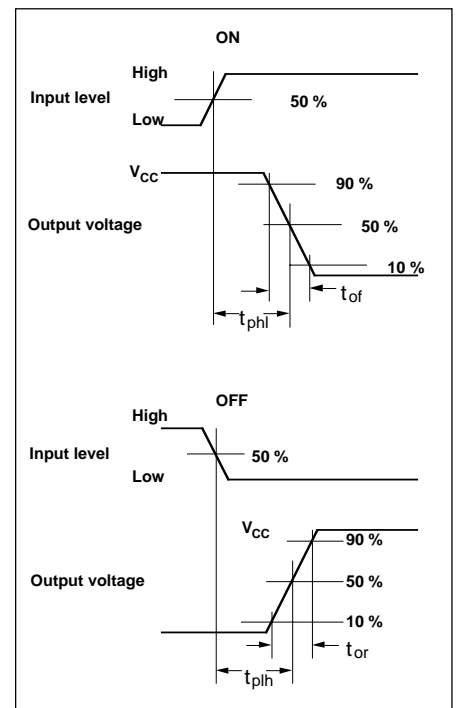

Figure 3. Timing diagram, input vs. output.  $V_{CC} = 24V$ .

## Electrical Characteristics

At  $5\text{ V} \leq V_{CC} \leq 40\text{ V}$ ,  $-40^\circ\text{C} \leq T_J \leq +100^\circ\text{C}$ . Typical values are given at  $V_{CC} = 24\text{ V}$ ,  $T_J = 25^\circ\text{C}$ .

Parameter	Symbol	Ref. fig.	Conditions	Min	Typ	Max	Unit
<b>General</b>							
Supply current	$I_{CC}$	2,7	$0 \leq V_{IN} \leq 0.8$	1.5	4	7	mA
Thermal shutdown	$T_{JS}$			+120	+130	+140	$^\circ\text{C}$
Thermal shutdown release	$T_{JSR}$			+110	+120	+130	$^\circ\text{C}$
<b>Logic input</b>							
High level input voltage	$V_{IH}$	2		2.0		$V_{CC}$	V
Low level input voltage	$V_{IL}$	2		-0.3		0.8	V
High level input current	$I_{IH}$	2,9	$2.0 \leq V_{IN} \leq V_{CC}$		9	20	$\mu\text{A}$
Low level input current	$I_{IH}$	2,9	$0 \leq V_{IN} \leq 0.8$	-400			$\mu\text{A}$
<b>Outputs</b>							
Error output saturation voltage	$V_{ErrSAT}$	2,10	$I_{Err} = 5\text{ mA}$		0.2	1	V
Output saturation voltage	$V_{CESAT}$	2,11	$I_{OUT} = 2\text{ A}$		1.4	1.8	V
Output current shutdown	$I_{OS}$	2,5,14	$2.0 \leq V_{IN} \leq V_{CC}$	2.0	3.2	4.5	A
Output current (not detected as open circuit)	$I_{OMIN}$	2,5	$2.0 \leq V_{IN} \leq V_{CC}$	0.5	2	8	mA
Output leakage current	$I_{OL}$	2,12	$0\text{ V} \leq V_{IN} \leq 0.8\text{ V}$ . Output = 0 V	-8	-6	-2	$\mu\text{A}$
Clamping diode forward voltage		8	$I_F = 2.0\text{ A}$		1.5	1.8	V
<b>Timing</b>							
Propagation time		3	$I_{OUT} = 2\text{ A}$				
Output high to low (50%),	$t_{phl}$				1.5	3.0	$\mu\text{s}$
Output low to high (50%),	$t_{plh}$				0.5	1.0	$\mu\text{s}$
Rise time (10 to 90%),	$t_{or}$	3			0.2	0.5	$\mu\text{s}$
Fall time (90 to 10%),	$t_{of}$	3			0.2	0.5	$\mu\text{s}$

## Thermal Characteristics

Parameter	Symbol	Ref. fig.	Conditions	Min	Typ	Max	Unit
Thermal resistance	$R_{th_{JC}}$	21	TO-220 package, junction to case		5		$^\circ\text{C/W}$
	$R_{th_{JA}}$	21	TO-220 package, junction to ambient		60		$^\circ\text{C/W}$
	$R_{th_{J-BW}}$	20	PLCC package, junction to batwing, note 4			10	$^\circ\text{C/W}$
	$R_{th_{J-A}}$	20,22	PLCC package, note 3.		35		$^\circ\text{C/W}$

Notes: 1. Currents are defined positive if flowing into, and negative if flowing out of a terminal. Voltages are defined between terminal and ground.

2. ESD testing according to Human Body Model ( $C_{Zap} = 100\text{ pF}$ ,  $R_{Zap} = 1500\ \Omega$ )

3. All ground pins soldered onto a  $20\text{ cm}^2$  PCB copper area with free air convection,  $T_A = +25^\circ\text{C}$ .

4. Batwing = Ground pins.

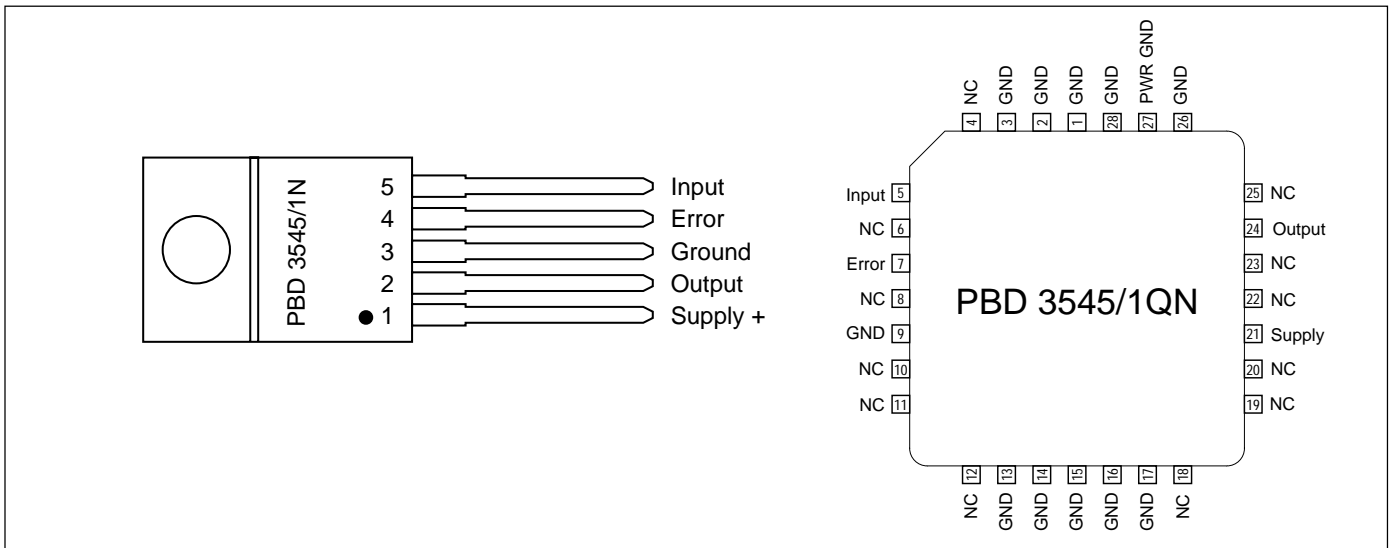

Figure 4. Pin descriptions.

### Pin Description

TO-220	PLCC	Symbol	Description
1	[21]	Supply	Supply voltage. Nominally 5 V to 40 V.
2	[24]	Output	Output pin. Current flows from supply through the load into the pin. Nominal current is 8 mA to 2 A.
3	[1-3,9, 13-17,26,28]	GND	Ground supply. Note: for PLCC these pins are used thermally for heat sinking. Make sure that all pins are soldered onto a suitably large copper ground for efficient heat sinking. Power ground pin.
	[27]	PWR GND	In the PLCC package, the emitter of the output transistor including the protection diode are bonded to a separate pin.
4	[7]	Error	Error indicating pin. Sinks current to ground if the protection and/or detection circuitry is activated. Note: the current must be externally limited to 8 mA.
5	[5]	Input	TTL compatible input. A LOW input signal turns the output transistor off and a HIGH input turns it on. If the input is left open it will be detected as low level.
NC	[4,6,8,10-12 18-20,22,23,25]		No connection. Pins are not bonded to the chip and may therefore be soldered to any PC board trace for efficient heat sinking.

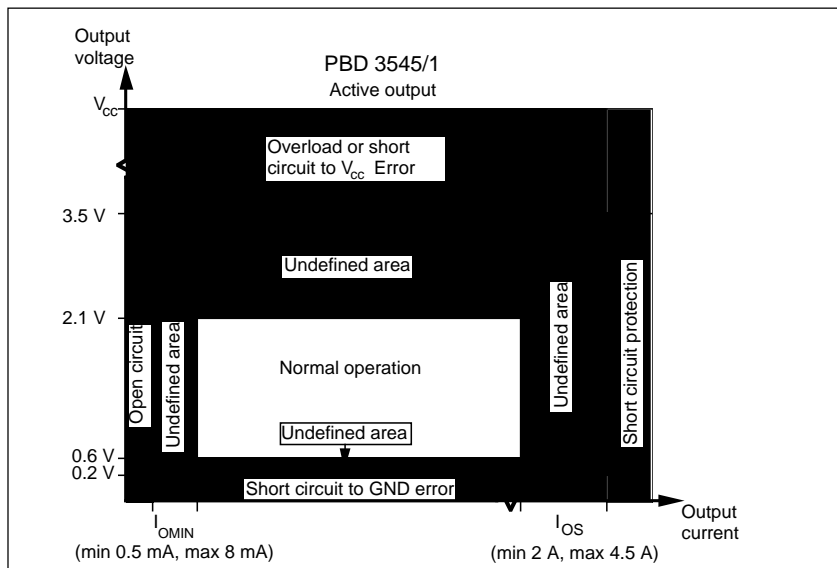

Figure 5. Error state vs. output voltage and output current, active output ( $2.0 \leq V_{IN} \leq V_{CC}$ ),  $5 V < V_{CC} < 40 V$ ,  $-40^{\circ}C < T_J < +100^{\circ}C$ .

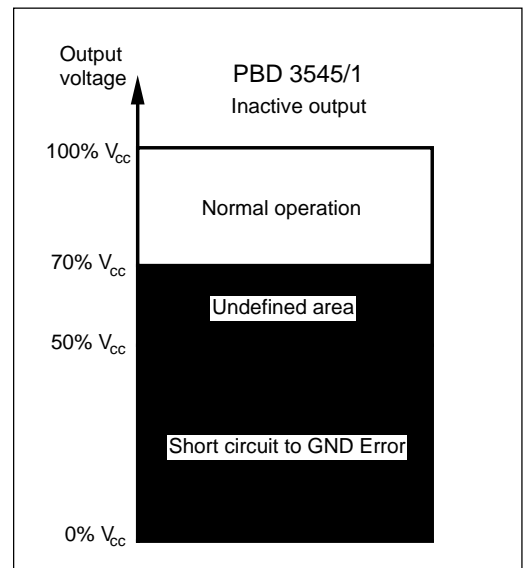

Figure 6. Error state vs. output voltage, inactive output ( $0 V \leq V_{IN} \leq 0.8 V$ ),  $5 V \leq V_{CC} \leq 40 V$ ,  $-40^{\circ}C < T_J < +100^{\circ}C$ .

**Typical Performance Characteristics**

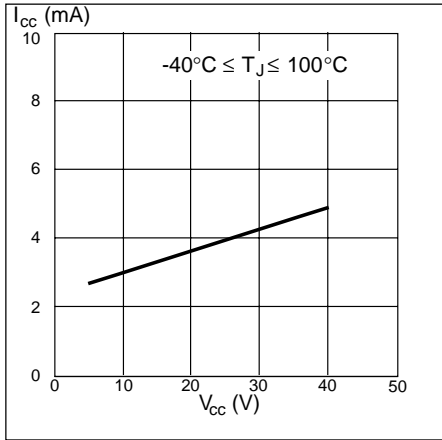

Figure 7. Current consumption vs. supply voltage at  $0 V \leq V_{in} \leq 0.8 V$ . (Inactive output)

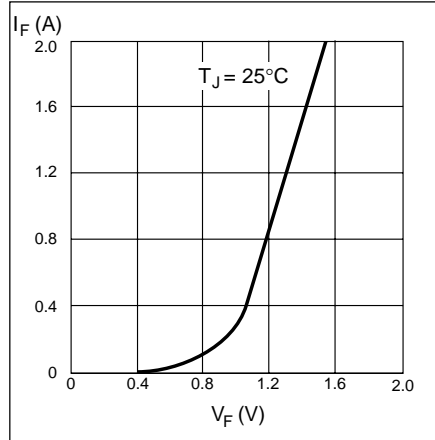

Figure 8. Diode forward voltage drop vs. forward current.

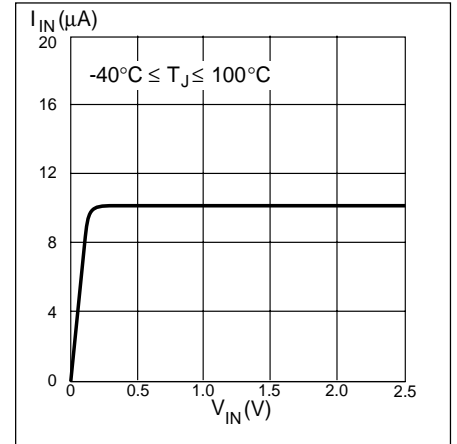

Figure 9. Input current vs. input voltage.  $5 V \leq V_{cc} \leq 40 V$ .

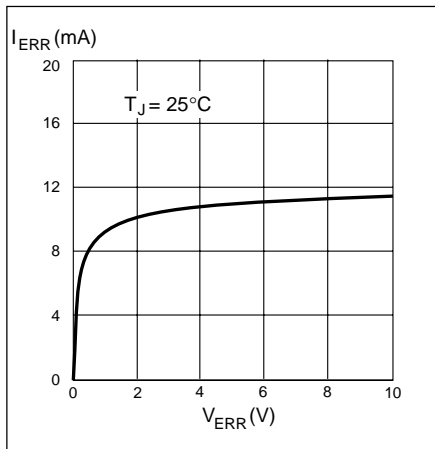

Figure 10. Error output saturation voltage vs. error current.  $V_{cc} = 24 V$ .

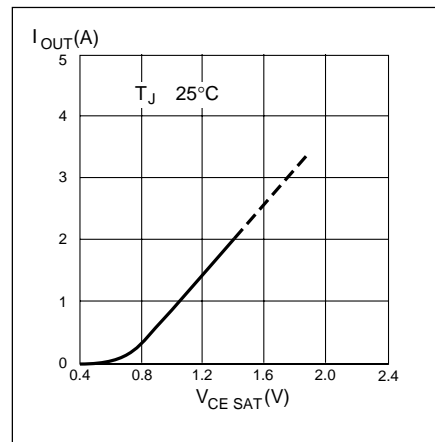

Figure 11. Output saturation voltage vs. output current.  $5 V < V_{cc} < 40 V$ .

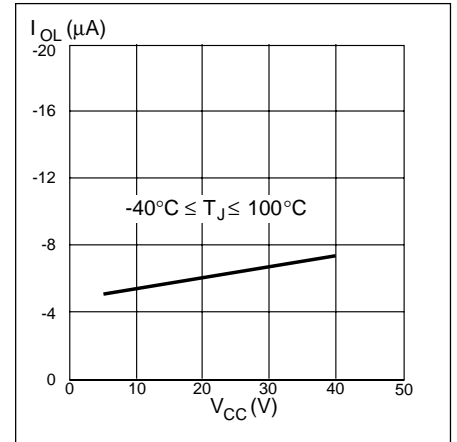

Figure 12. Output leakage current vs. supply voltage.  $0 V \leq V_{in} \leq 0.8 V$ . Output = 0 V.

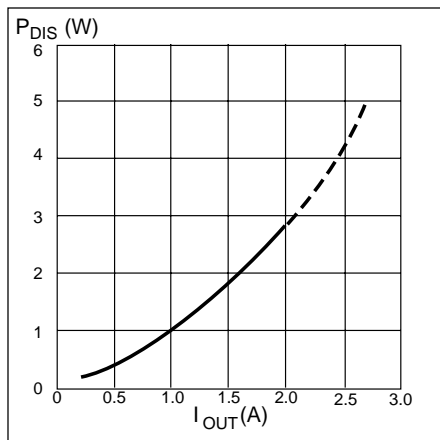

Figure 13. Power dissipation vs. output current.

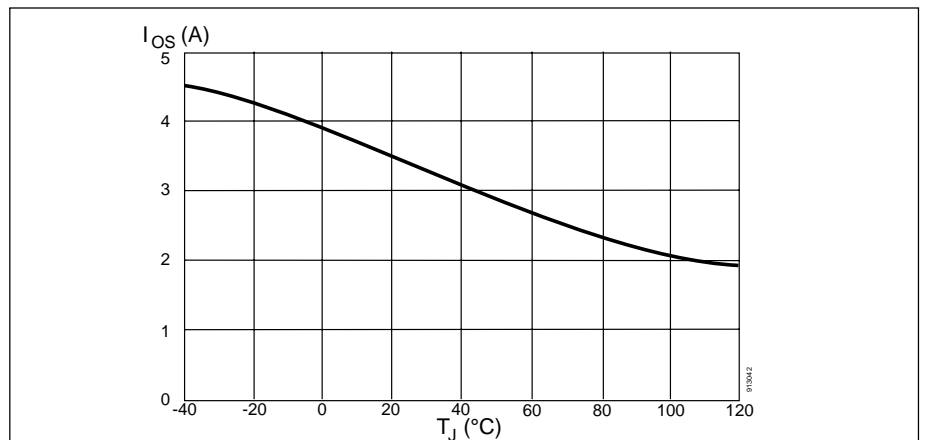

Figure 14. Typical output current shut-down vs. chip temperature.  $5 V \leq V_{cc} \leq 40 V$ .

**Functional Description**

The circuit PBD 3545/1 is a low side driver capable of driving resistive or inductive loads not exceeding 2 A.

The driver has an error indicating function which generates an Error output signal when a fault condition has occurred.

The circuits PBD 3545/1 and PBD 3548/1 are complementary drivers with equivalent functions and similar data. PDB 3545/1 is a sink driver and PBD 3548/1 is a source driver.

**Input stage**

The output stage is switched on and off according to the status of the input. HIGH level activates the output. If the input is left open, the circuit will accept it as a LOW level.

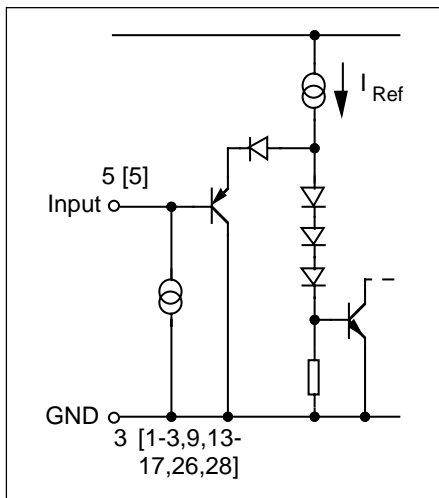

Figure 15. Input stage.

**Output stage**

The output stage contains a power transistor and two clamping diodes. The diodes are used for terminating line transients from inductive loads. If the driver is inactive and the output is shorted to GND the driver will leak maximum 8  $\mu$ A. See figure 12.

**Protection circuitry**

The circuit contains two protection circuits:

- Overload and Short circuit protection
- Thermal protection

The overload and short circuit protection will be activated at  $I_{out} = 3.5$  A typically at  $T_j = +25^\circ\text{C}$ , see figure 14.

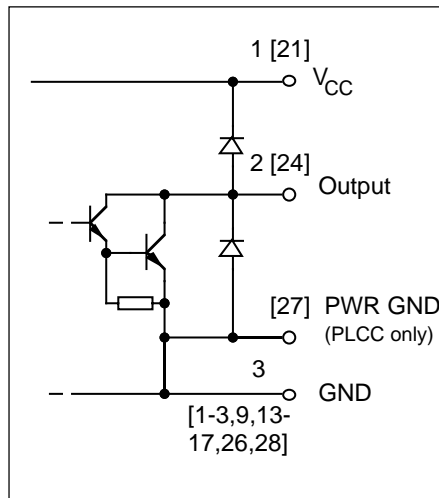

Figure 16. Output stage.

The output will be turned off immediately and latched to a high-impedance state after an overload or short circuit has been detected.

A logic-level change at the input will reset the internal error latch. If the fault still is present at turn-on, the circuit will once again turn the output off.

Due to a slight delay in the circuit, a high current transient will occur when the output is shorted to  $V_{cc}$ . This current transient may reach 8 A during 5  $\mu$ s. Consequently, switching at high frequencies with a shorted output may destroy the circuit. If a short circuit condition is detected, stop switching the input and remove fault condition.

**Thermal protection**

The output of PBD 3545/1 is equipped with a thermal shut-down function, which limits the junction temperature to typically  $+130^\circ\text{C}$ . The output will be turned off until the junction temperature has decreased to approximately  $120^\circ\text{C}$ .

**Error functions**

The Error indicating signal occurs on a separate pin. The complete error table is shown in figure 17.

The following conditions generate an error signal:  
When the driver is activated and at least one of the following conditions has occurred:

Fault condition	Input	Output	Error LOW=ERROR HIGH=Normal	How to resume normal operation
Normal	0 LOW 1 HIGH	1 OFF 0 ON	1 HIGH 1 HIGH	— —
$V_{OUT}$ Short to GND	0 LOW 1 HIGH	1 OFF 0 ON	0 LOW 0 LOW	Remove fault condition. Remove fault condition.
$V_{OUT}$ Short to $V_{CC}$	0 LOW 1 HIGH	1 OFF 1 OFF	1 HIGH 0 LOW	— Turn off and on after fault condition is removed.
Open load	0 LOW 1 HIGH	1 OFF 0 ON	1 HIGH 0 LOW	— Attach proper load to output or turn off the driver.
Over temperature $T_j=130^\circ\text{C}$	0 LOW 1 HIGH	1 OFF 1 OFF	1 HIGH 0 LOW	— Temperature is reduced to approx $120^\circ\text{C}$ , or turn off the driver.

Figure 17. Error table.

- thermal overload
- short circuit to GND
- short circuit to  $V_{CC}$
- open circuit

An output current less than 8 mA might be detected as "open circuit". Output currents larger than 8 mA and less than 2 A will definitely not generate an error. The normal operational area is shown in figure 5.

Also when the driver is inactivated an Error indication can occur. That is if the output is shorted to GND. In figure 6 short circuit to GND Error state versus output voltage is shown.

When the Error-detection function is activated, the Error output is capable of sinking 8 mA, supporting direct connection of an LED. The current has to be externally limited by a series resistor.

**Signal diagrams**

The signal diagram in figure 18 shows the input signal and the resulting output signals for each error mode. For details, see error table, figure 17.

- $V_{IN}$  = Input voltage. Active = HIGH.
- $V_{OUT}$  = Output voltage.
- $I_{OUT}$  = Output current from driver.
- $V_{ERR}$  = Error output voltage.
- Error = LOW.

**Applications Information**

Important application areas are:

- Programmable logic control systems.
- Security systems.
- Relay control.
- Hydraulic valves.
- Intelligent interfaces between microprocessors and loads.
- Vehicle control systems.
- Robot techniques.
- Dashboard information systems.
- Print head drivers.
- High-current stepper motor drivers with security aspects.

**Transient protection**

1. Keep  $V_{CC}$  and GND leads as short as possible.
2. Connect a filter capacitor close to the circuit. Recommended filter capacitor between  $V_{CC}$  and GND is 6.8  $\mu$ F, of tantalum type. A ceramic capacitor in

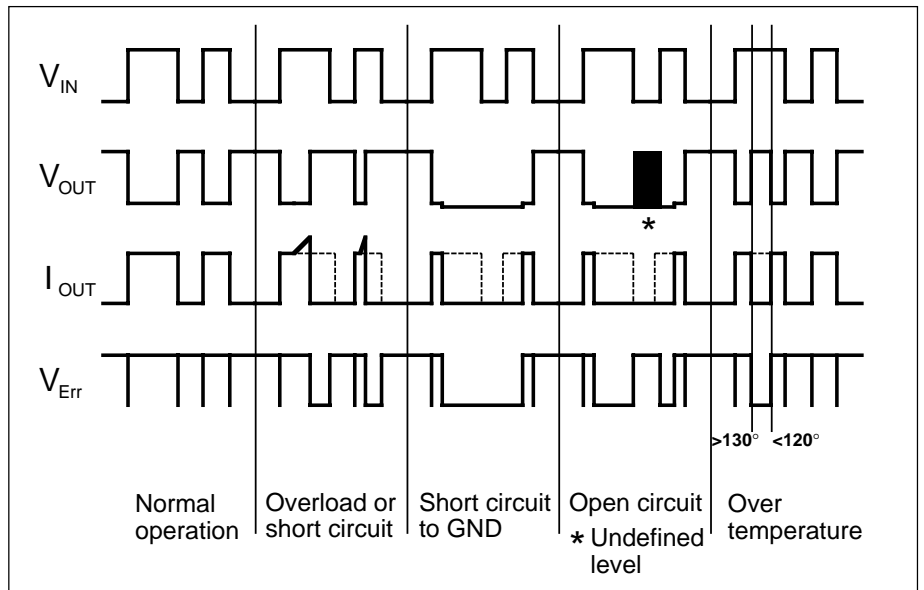

Figure 18. Signal diagram.

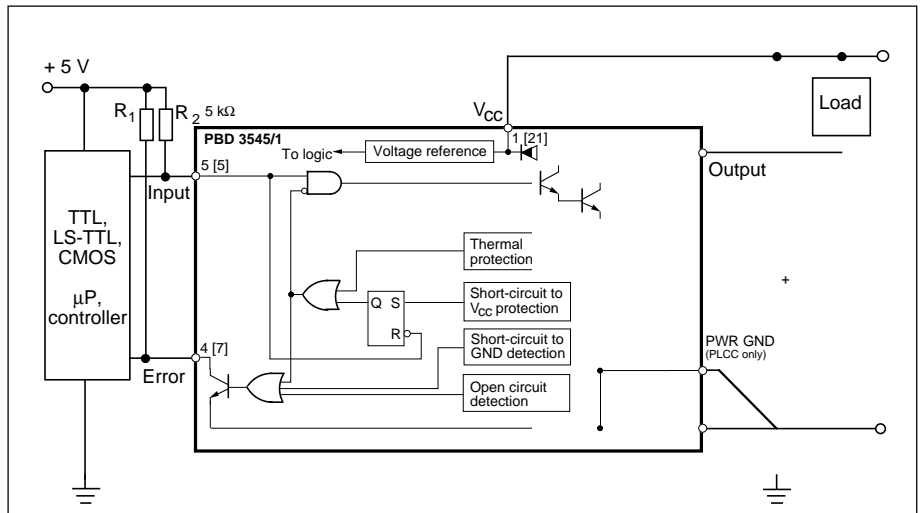

Figure 19. Typical application. Pin numbers refer to TO 220 package.

parallel will improve high frequency decoupling. Typical values range from 0.002  $\mu$ F to 0.1  $\mu$ F. In an application having a highly stable supply and short power leads to the driver a low leakage electrolytic type can be used, which is less expensive.

3. Connect Input and Error via pull-up resistors to the appropriate logic supply level or  $V_{CC}$  to obtain highest noise immunity. See figure 19. The resistor  $R_1$  limits the current into the Error indicating pin. This current must not exceed 8 mA.  $R_2$  is a pull-up resistor which improves noise immunity at the Input. Pull-up current should not exceed the sinking capacity of the controlling device output.

4. If several supply voltages are to be used, prefer a supply having separate ground leads. In this case the logic ground and the power ground should be connected together at only one point, the ground pin of the driver.

**Switch mode applications**

The internal diodes are normally sufficient for clamping of transients caused by inductive load turn off. External diodes may be necessary in PWM/switch mode applications, and when the terminals are externally accessible and thereby exposed to an electrically noisy environment. Recommended diodes are BYV27/100, BYV98/100, UF4001 or similar types with a  $t_{rr} < 100$  ns and  $I_F \geq 1$  A.

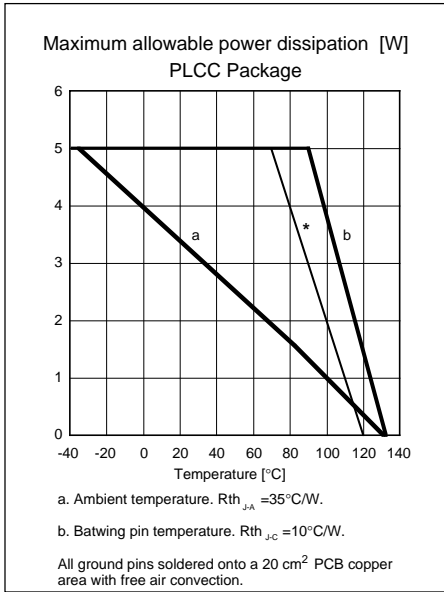

Figure 20. Maximum allowable power dissipation. PLCC package.

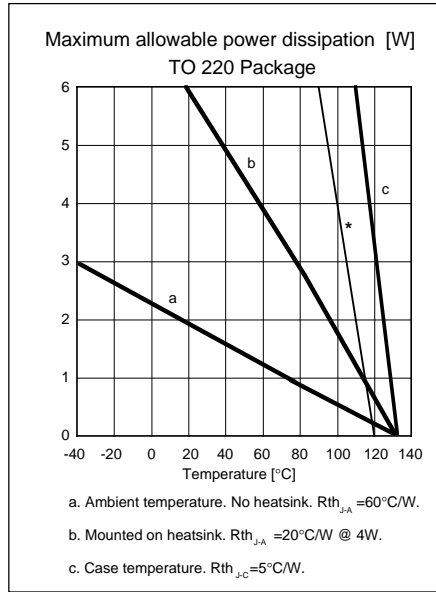

Figure 21. Maximum allowable power dissipation. TO 220 package.

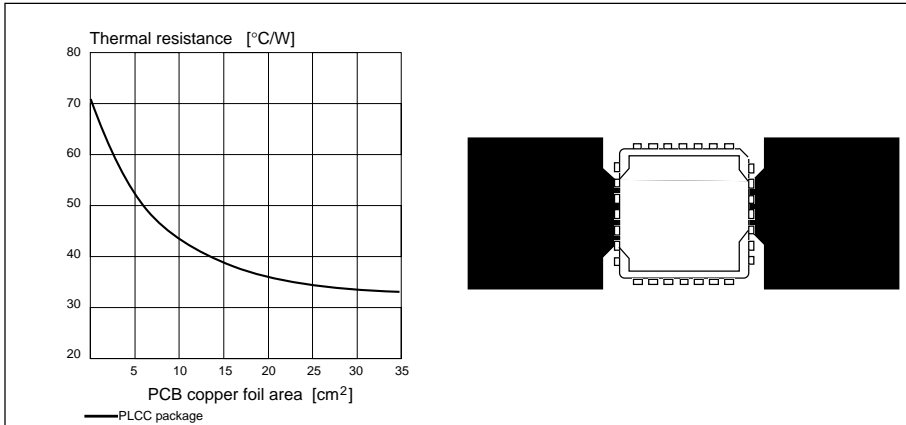

Figure 22. Typical thermal resistance vs. PC board copper area and suggested layout.

**Error indication signal**

When the circuit is switched on/off, a short pulse ( $t_{Err} < 10 \mu\text{S}$  for resistive loads) is generated at the Error output. This is a correct detection of an incorrect level during the rise and fall times of the output voltage. Consequently the Error output should not be detected when switching on and off. An alternative is to low-pass filter at the Error output at around 100 kHz.

**Heat sinking**

PBD 3545/1N is packaged in a 5-pin TO 220 power package. The circuit GND is connected to the heat sink tab. External heatsinking is achieved by mounting the package to a heat sink.

The circuit is also available in a 28 pin power PLCC package. In the PLCC package the circuit ground is connected to the lead frame batwing. External heatsinking is achieved by soldering the ground leads onto a copper ground plane. Note: The power ground pin (PWR GND) should also be connected to the ground plane.

Maximum continuous output current is heavily dependant on the heatsinking applied and ambient temperature. Consult figures 13, 20, 21 and 22 to determine the maximum output current under varying conditions.

Information given in this data sheet is believed to be accurate and reliable. However no responsibility is assumed for the consequences of its use nor for any infringement of patents or other rights of third parties which may result from its use. No license is granted by implication or otherwise under any patent or patent rights of Ericsson Components. These products are sold only according to Ericsson Components' general conditions of sale, unless otherwise confirmed in writing.

Specifications subject to change without notice.

1522-PBD 3545/1 Uen Rev.B  
© Ericsson Components 1993

**Ordering Information**

Package	Temp. range
TO-220	-40 to +85°C
PLCC	-40 to +85°C

Part No.
PBD 3545/1N
PBD 3545/1QN