

**Silicon RF Switching Diode**

- Low loss, low capacitance PIN-diode
- Band switch for TV-tuners
- Series diode for mobile communication transmit-receiver switch

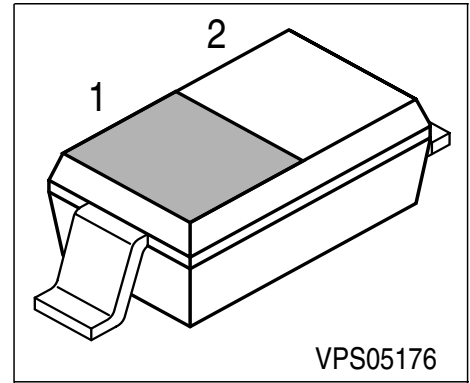

Type	Marking	Pin Configuration		Package
BAR 65-03W	M/blue	1 = C	2 = A	SOD-323

**Maximum Ratings**

Parameter	Symbol	Value	Unit
Diode reverse voltage	$V_R$	30	V
Forward current	$I_F$	100	mA
Operating temperature range	$T_{op}$	-55 ... 125	°C
Storage temperature	$T_{stg}$	-55 ... 150	

**Electrical Characteristics** at  $T_A = 25^\circ\text{C}$ , unless otherwise specified.

Parameter	Symbol	Values			Unit
		min.	typ.	max.	
<b>DC characteristics</b>					
Reverse current $V_R = 20\text{ V}$	$I_R$	-	-	20	nA
Forward voltage $I_F = 100\text{ mA}$	$V_F$	-	0.93	1	V
<b>AC Characteristics</b>					
Diode capacitance $V_R = 1\text{ V}, f = 1\text{ MHz}$ $V_R = 3\text{ V}, f = 1\text{ MHz}$	$C_T$	- -	0.6 0.57	0.9 0.8	pF
Forward resistance $I_F = 5\text{ mA}, f = 100\text{ MHz}$ $I_F = 10\text{ mA}, f = 100\text{ MHz}$	$r_f$	- -	0.65 0.56	0.95 0.9	$\Omega$
Charge carrier life time $I_F = 10\text{ mA}, I_R = 6\text{ mA}, I_R = 3\text{ mA}$	$\tau_{rr}$	-	80	-	ns
Series inductance	$L_s$	-	1.8	-	nH

**Forward current  $I_F = f(V_F)$**

$T_A = 25^\circ\text{C}$

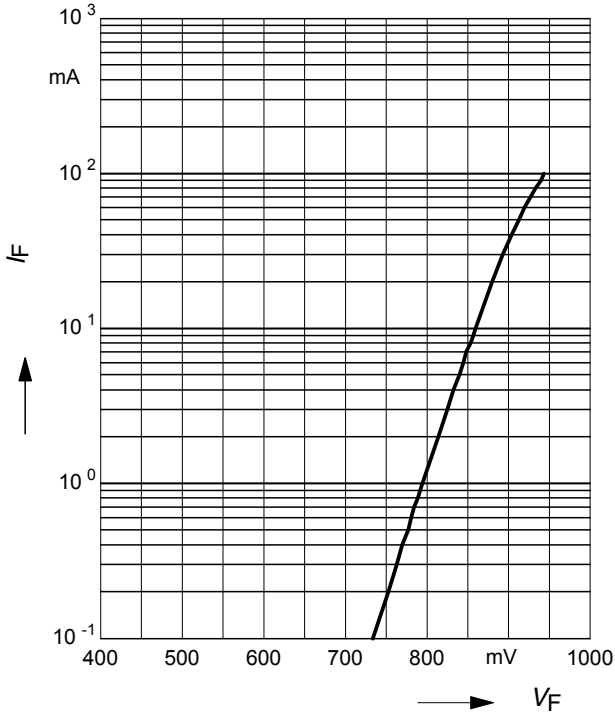

**Forward resistance  $r_f = f(I_F)$**

$f = 100\text{MHz}$

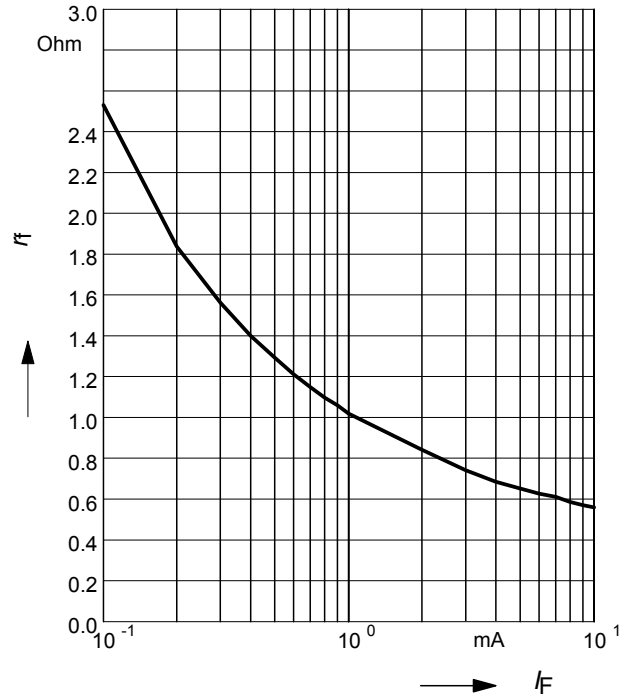

**Diode capacitance  $C_T = f(V_R)$**

$f = 1\text{MHz}$

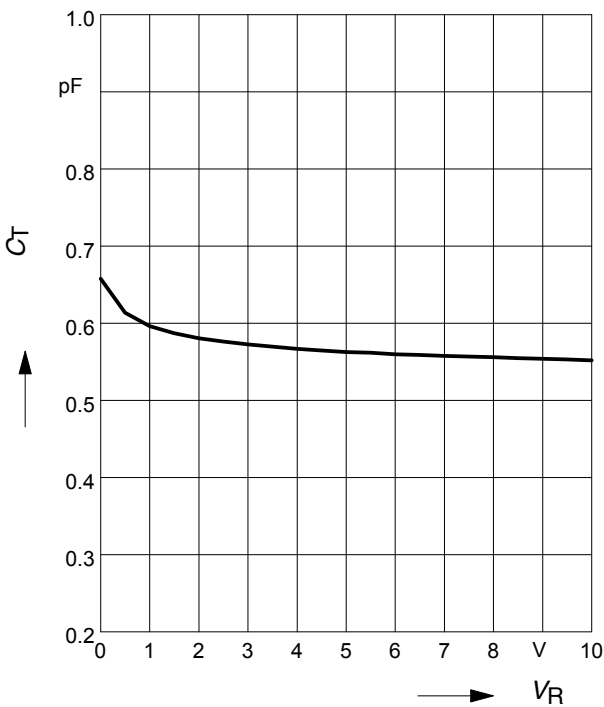

**Diode capacitance  $C_T = f(V_R)$**

$f = 100\text{MHz}$

