

T-77-05-07

**3V FM/AM IF System
 BA4228L**

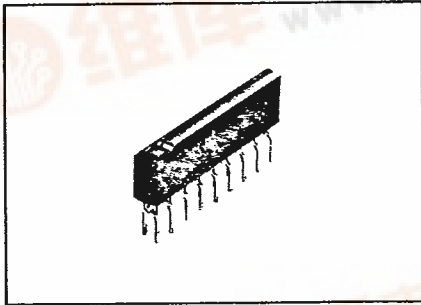

Dimensions (Unit : mm)

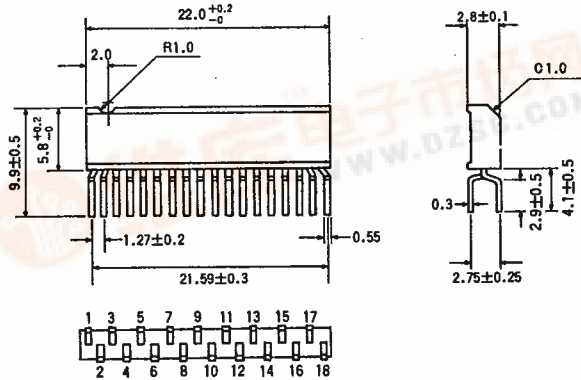

The BA4228L is a single-chip FM/AM IF system designed for use in 3V radios. The FM block of the device consists of a differential IF amplifier, quadrature detector, and IF soft muting circuit for weak input. The AM block consists of a local oscillator, double-balanced mixer, IF amplifier, detector, and AGC network. The device also contains an audio amplifier.

Features

1. Capable of withstanding supply voltage drops (down to $V_{CC}=1.5V$ typ. when $V_{OUT}=-3$ dB).
2. Built-in FM muting network suppresses inter-station noise and off-tuned side peaks. The muting level can be adjusted with an external resistor.
3. Single-pin output for FM and AM circuits allows coupling to the following stage (MPX, etc.) without the need for a selector switch.
4. Low-pass filter pin dedicated to the AM circuitry enables independent frequency response settings for FM and AM blocks. This facilitates coupling to the demultiplexer circuit.
5. Switching between FM and AM modes can be controlled by a DC level (on/off).

Block Diagram

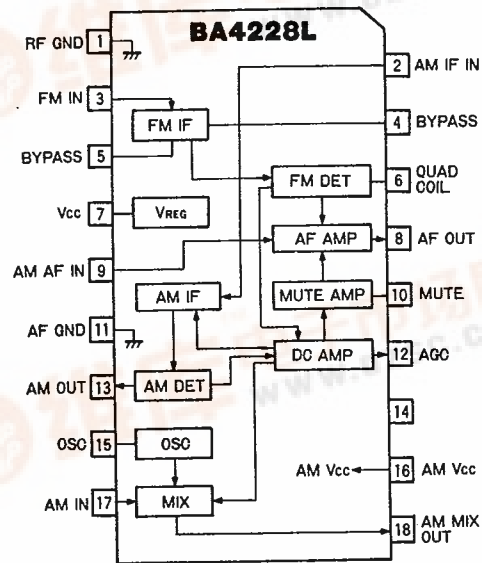

Applications

FM/AM portable radios
 Headphone radio cassette recorders

Absolute Maximum Ratings (Ta=25°C)

Parameter	Symbol	Limits	Unit
Supply voltage	Vcc	4.5	V
Power dissipation	Pd	500*	mW
Operating temperature range	Topr	-25~75	°C
Storage temperature range	Tstg	-55~125	°C

* Derating is done at 5mW/°C for operation above Ta=25°C

Recommended Operating Conditions

Parameter	Symbol	Min.	Typ.	Max.	Unit	Conditions
Supply voltage	Vcc	1.8	3	3.6	V	-



Electrical Characteristics / FM Block (Ta=25°C, Vcc=3V)

Parameter	Symbol	Min.	Typ.	Max.	Unit	Conditions
Quiescent current	I _Q	-	7	12	mA	Muting off
Detector output	V _{OUT}	55	85	115	mV	V _{IN} =100 dBμV, 10.7 MHz Δf=22.5 kHz, f _m =1 kHz
Total harmonic distortion	THD	-	0.25	0.75	%	V _{IN} =100 dBμV, 10.7 MHz Δf=22.5 kHz, f _m =1 kHz
Signal-to-noise ratio	S / N	60	68	-	dB	V _{IN} =100 dBμV, 10.7 MHz Δf=22.5 kHz, f _m =1 kHz
Limiting sensitivity	V _{IN(lim)}	30	35	40	dBμV	V _{OUT} =-3 dB
Minimum supply voltage	V _{CC}	-	1.5	1.7	V	V _{OUT} =-3 dB

Electrical Characteristics / AM Block (Ta=25°C, Vcc=3V)

Parameter	Symbol	Min.	Typ.	Max.	Unit	Conditions
Quiescent current	I _Q	-	6	10	mA	-
Detector output	V _{OUT}	55	80	110	mV	V _{IN} =74 dBμV, 1 MHz f _m =1 kHz, 30 %
Total harmonic distortion	THD	-	0.5	2.5	%	V _{IN} =74 dBμV, 1 MHz f _m =1 kHz, 30 %
Signal-to-noise ratio	S / N	42	50	-	dB	V _{IN} =100 dBμV, 1 MHz f _m =1 kHz, 30 %
Limiting sensitivity	S	7	12	17	dBμV	V _{OUT} =10 mV
Minimum supply voltage	V _{CC}	-	1.5	1.7	V	V _{OUT} =-3 dB

Test Circuit

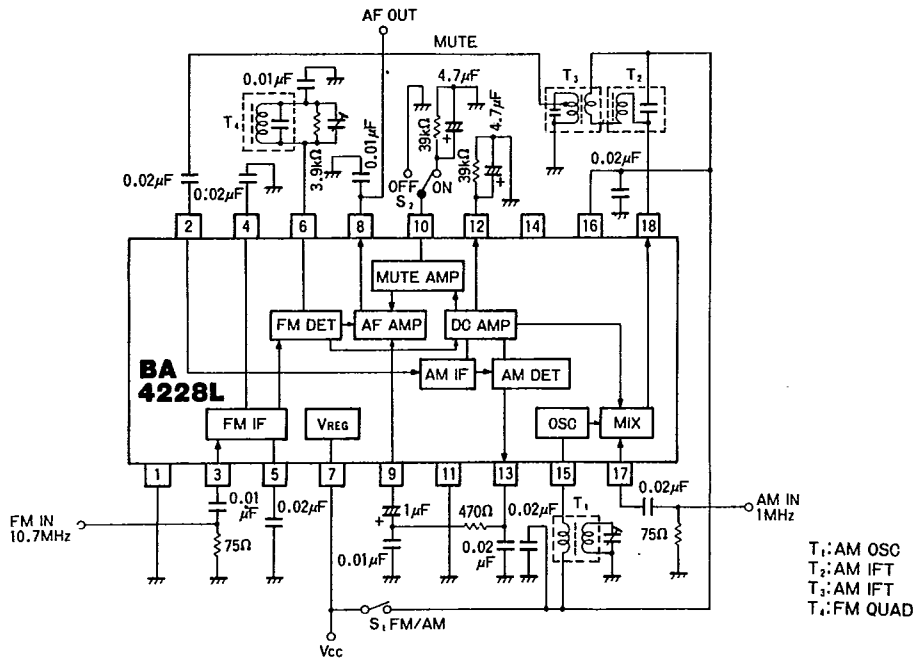

Fig. 3

Note : Pin 14 should be either grounded or left open.

Precautions for Use

1. Leakage from AM local oscillation or noise applied to the AM IF input (pin 2) may reduce sensitivity. To prevent this, locate the ground point for the AM IF ceramic filters in the close vicinity of pin 1, and use the shortest possible wiring path between the ceramic filter output and IF input pin (pin 2). Use AM ceramic filters with low spurious response, and connect a capacitor of 100 to 220 pF across the IF input pin (pin 2) and the GND.
2. Locate the ground point for the

- bypass capacitors used for the IF amplifiers in the close vicinity of pin 1.
3. When observing the S-shaped discrimination curve of the FM block with an oscilloscope and sweep generator, turn off muting. Otherwise, observation error will occur due to the time constant in the muting network.
4. Note that the FM muting level will vary according to the noise level at the front end.
5. The value of the AM local oscillation's stabilizing resistor, R_s, should be between 0 and 100Ω.

6. Pin 14 should be grounded or left open. Do not connect it to any other point. (Fig. 4)

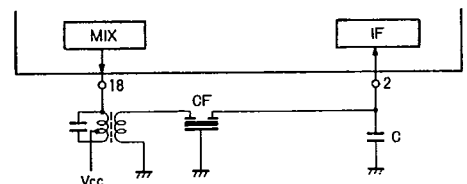

Fig. 4

Application Example

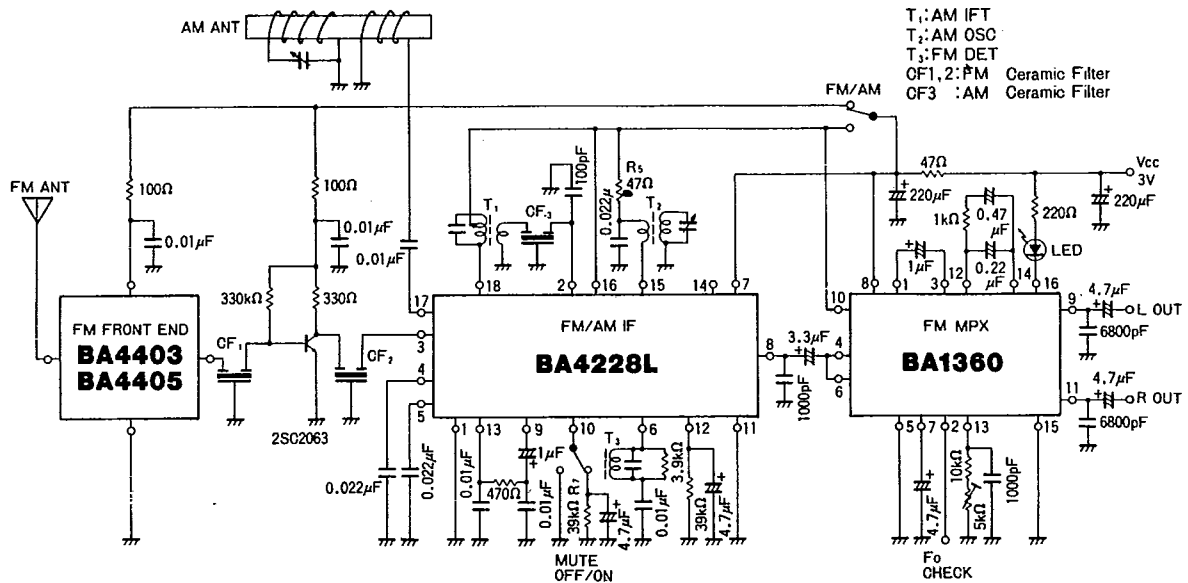

Fig. 5

Electrical Characteristic Curves

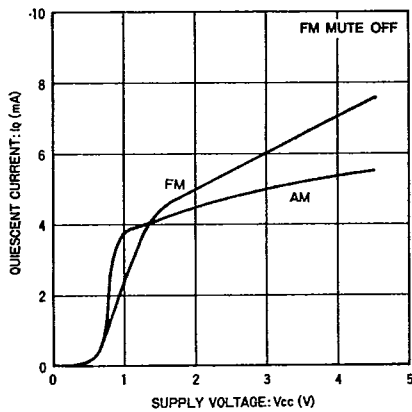

Fig. 6 Quiescent current vs. supply voltage

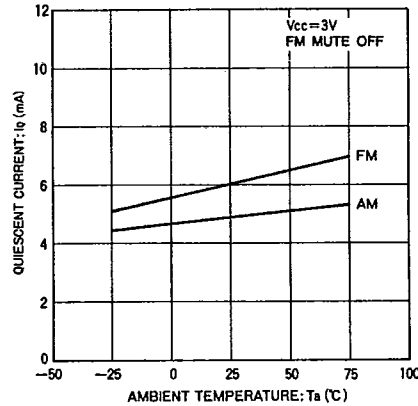

Fig. 7 Quiescent current vs. ambient temperature

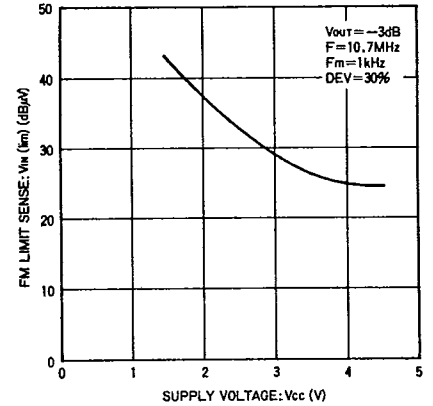

Fig. 8 FM limiting sensitivity vs. supply voltage

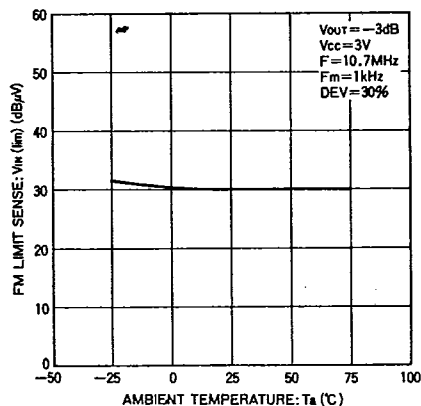

Fig. 9 FM limiting sensitivity vs. ambient

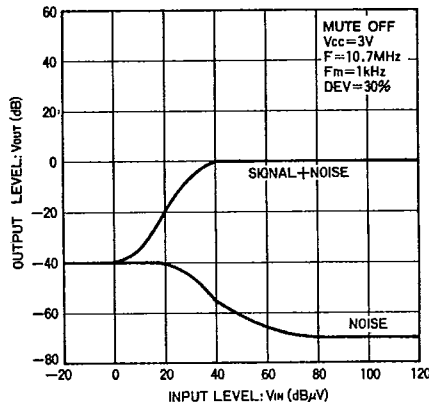

Fig. 10 FM output level vs. input level

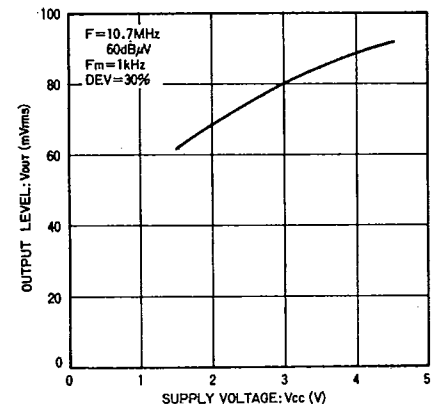

Fig. 11 FM output level vs. supply voltage

Electrical Characteristic Curves

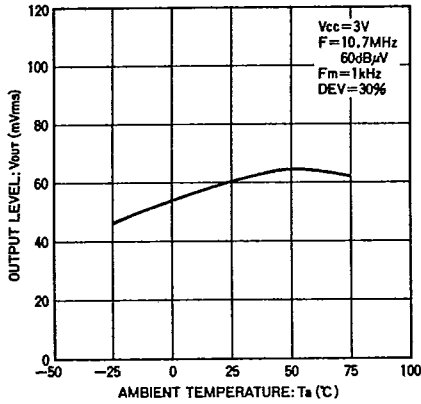

Fig. 12 FM output level vs. ambient temperature

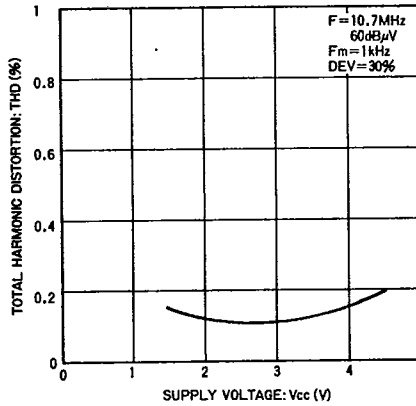

Fig. 13 FM total harmonic distortion vs. supply voltage

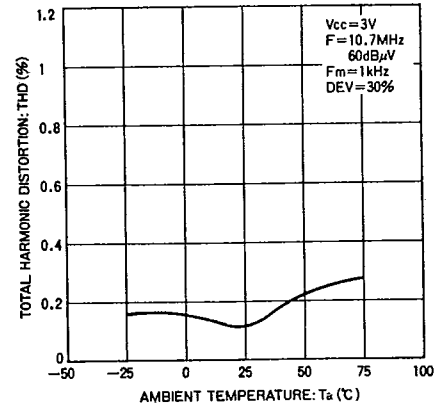

Fig. 14 FM total harmonic distortion vs. ambient temperature

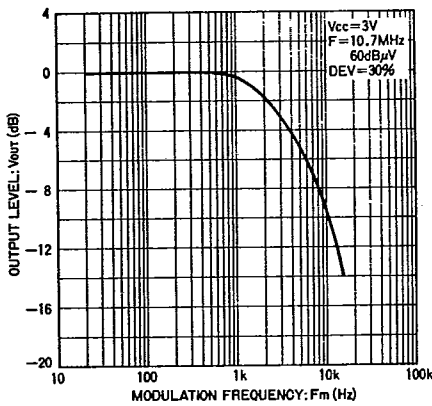

Fig. 15 FM output level vs. modulation frequency

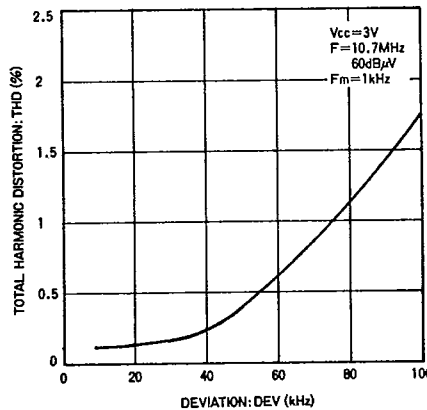

Fig. 16 FM total harmonic distortion vs. frequency deviation

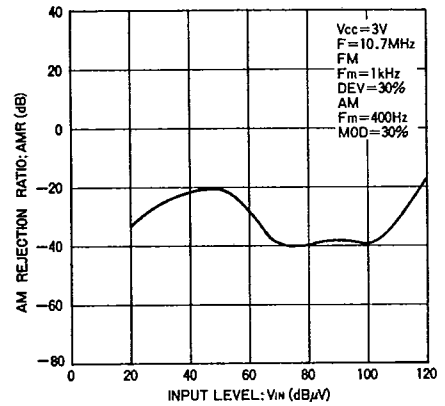

Fig. 17 AM rejection ratio vs. input level

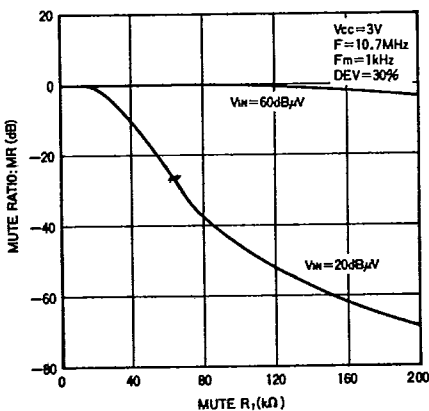

Fig. 18 FM muting ratio vs. resistance R7

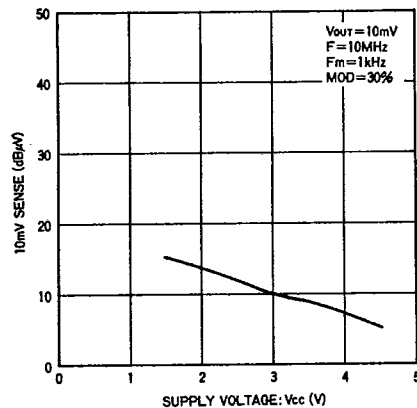

Fig. 19 AM 10 mV sensitivity vs. supply voltage

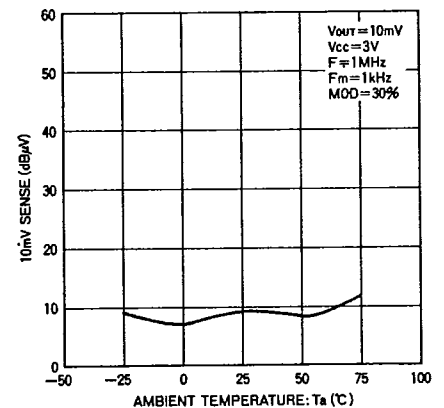

Fig. 20 AM 10 mV sensitivity vs. ambient temperature

T-77-05-07

Electrical Characteristic Curves

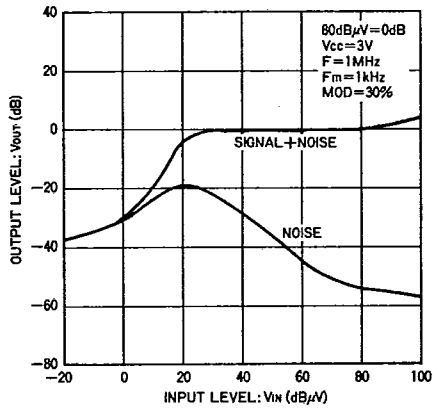

Fig. 21 AM output level vs. input level

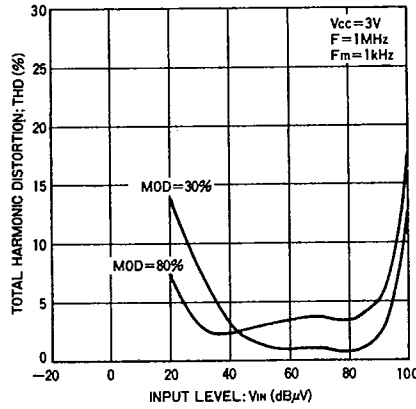

Fig. 22 AM total harmonic distortion vs. input level

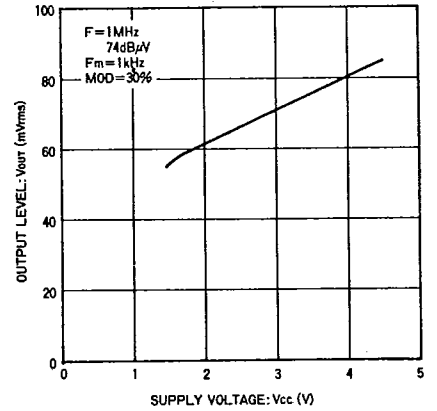

Fig. 23 AM output level vs. supply voltage

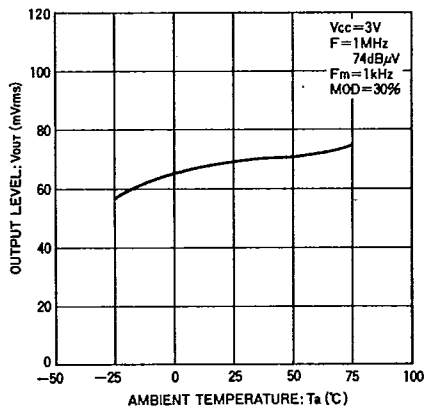

Fig. 24 AM output level vs. ambient temperature

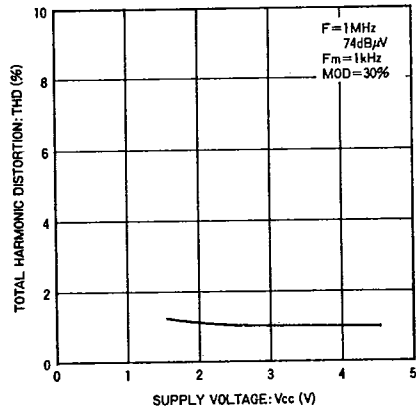

Fig. 25 AM total harmonic distortion vs. supply voltage

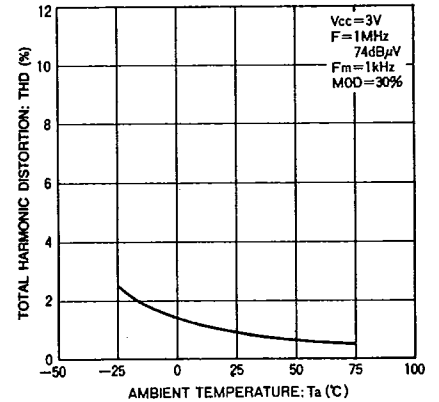

Fig. 26 AM total harmonic distortion vs. ambient temperature

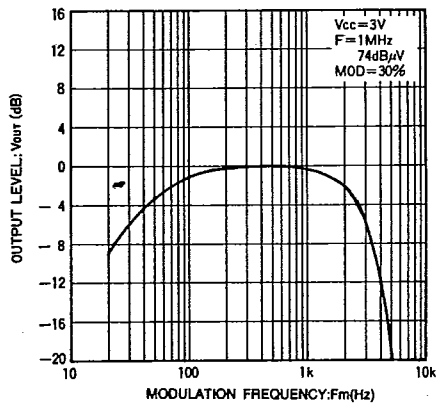

Fig. 27 AM output level vs. modulation frequency

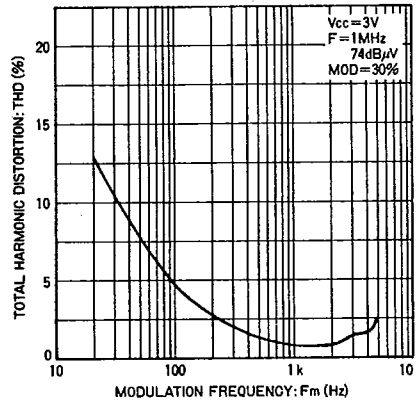

Fig. 28 AM total harmonic distortion vs. modulation frequency