

Dual output voltage regulator with power saving

BA41W12ST

The BA41W12ST is a general-purpose power supply with two outputs : 8V, 1A and 5V, 500mA. The IC is available in a compact TO220FP-5 package. The outputs can be turned off during the power saving state with a built-in switch. Also built in the IC are an overcurrent protection circuit, an overvoltage protection circuit, and a thermal shutdown circuit.

●Applications

Car audio systems, VCRs, fax machines, air conditioners, and other household and industrial equipment

●Features

- 1) Dropout voltage is 0.5V or less.
- 2) Built-in protection circuits against overcurrent, overvoltage, and overheat.
- 3) Available in a compact TO220FP-5 package (pins are bendable).
- 4) Zero power saving current. (Typ.)

●Block diagram

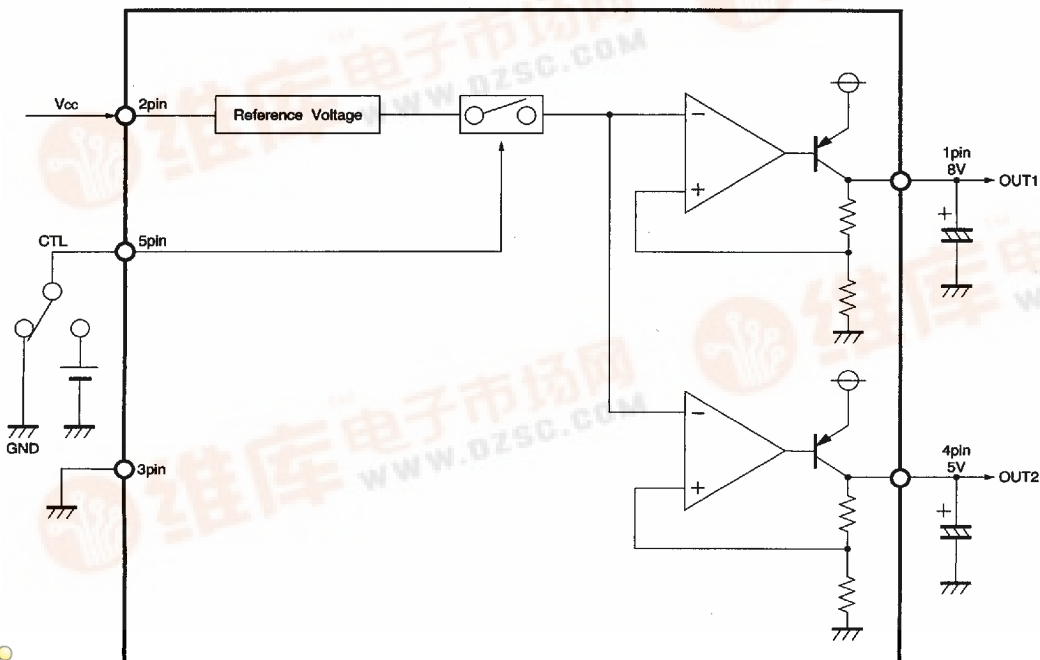

● Absolute maximum ratings (Ta=25°C)

Parameter	Symbol	Limits	Unit
Power supply voltage	V	35	V
Power dissipation	Pd	2000*1	mW
Operating temperature	Topr	-40~+85	°C
Storage temperature	Tstg	-55~+150	°C
Peak applied voltage	Vcc Peak	50*2	V

*1 Reduce power by 16 mW for each degree above 25°C.

*2 Less than 200 msec (tr ≥ 1 msec).

● Recommended operating conditions (Ta=25°C)

Parameter	Symbol	Min.	Typ.	Max.	Unit
Power supply voltage	Vcc	9.0	13	25	V

● Pin description

Pin No.	Pin name	Function
1	OUT1	Output 1 (8 V, 1 A)
2	Vcc	Power supply pin
3	GND	Ground pin
4	OUT2	Output 2 (5 V, 500 mA)
5	CTL	ON/OFF switch

● Input/output circuits

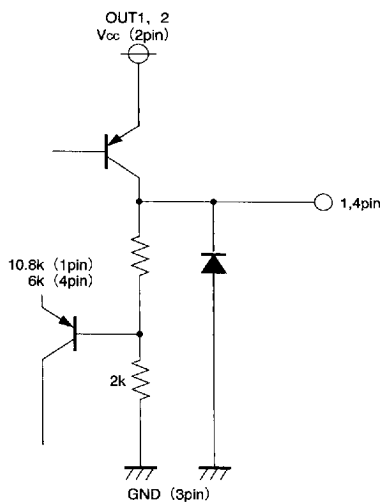
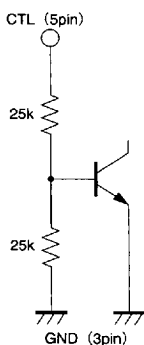

●Electrical characteristics (unless otherwise noted, Ta=25°C and Vcc=13.0V)

Parameter	Symbol	Min.	Typ.	Max.	Unit	Conditions	Measurement circuit
Power save circuit current	Ist	—	0	10	μA	OFF mode	Fig.4
Bias current	Ib	—	3.0	5.0	mA	ON mode	Fig.4
[8V output section]							
Output voltage 1	Vo1	7.6	8.0	8.4	V	Io1=500mA	Fig.1
Drop out voltage 1	ΔVo1	—	0.3	0.5	V	Io1=500mA Vcc=0.95Vo	Fig.3
Output current capacity 1	Io1	1.0	—	—	A		Fig.1
Ripple rejection 1	R.R1	—	55	—	dB	Io1=500mA, f=120Hz ein=1Vrms	Fig.2
Line regulation 1	Reg.I1	—	50	100	mV	Vcc=9→25V, Io=500mA	Fig.1
Load regulation 1	Reg.L1	—	100	150	mV	Io=5mA→1A	Fig.1
Output short-circuit current 1	Ios1	—	150	—	mA	Vcc=25V	Fig.5
[5V output section]							
Output voltage 2	Vo2	4.75	5.0	5.25	V	Io2=350mA	Fig.1
Drop out voltage 2	ΔVo2	—	0.3	0.5	V	Io2=350mA Vcc=0.95Vo	Fig.3
Output current capacity 2	Io2	500	—	—	mA		Fig.1
Ripple rejection 2	R.R2	—	60	—	dB	Io2=350mA, f=120Hz ein=1Vrms	Fig.2
Line regulation 2	Reg.I2	—	50	100	mV	Vcc=6→25V, Io=350mA	Fig.1
Load regulation 2	Reg.L2	—	50	100	mV	Io=5mA→500mA	Fig.1
Output short-circuit current 2	Ios2	—	100	—	mA	Vcc=25V	Fig.5
[Switch section]							
ON mode voltage	Vth1	2.0	—	—	V	Output ACTIVE mode	Fig.6
OFF mode voltage	Vth2	—	—	0.8	V	Output OFF mode	Fig.6
Input current when HIGH	Iin	—	150	—	μA	Vth=5V	Fig.7

Note: All the characteristic values are measured with a 0.33 μF capacitor connected to the input pin and a 22 μF capacitor connected to the output pin.

Measurements are made by using a pulse (tw ≤ 10ms, duty cycle ≤ 5%) in all cases but noise voltage and the ripple rejection ratio.

● Measurement circuit

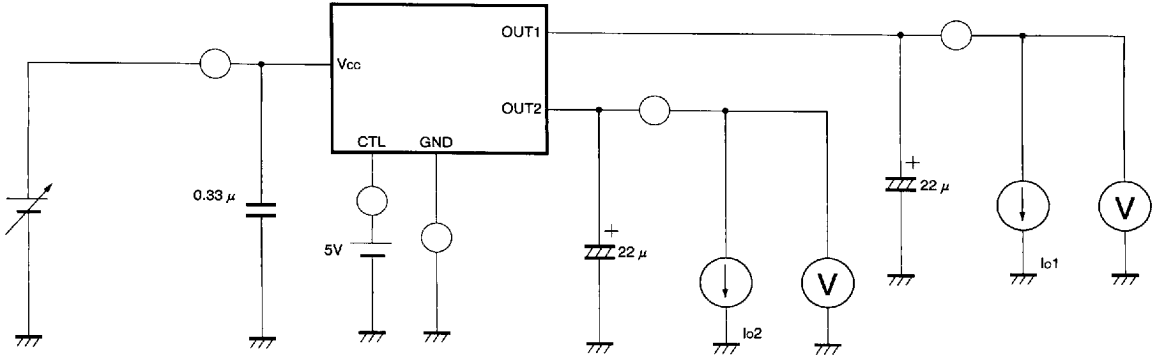

- | | | |
|---------------|-----------------|--|
| Vcc = 13 V, | Io = 500 mA | when measuring output voltage 1 |
| Vcc = 13 V, | Io = 350 mA | when measuring output voltage 2 |
| Vcc = 9→25 V, | Io = 500 mA | when measuring line regulation 1 |
| Vcc = 6→25 V, | Io = 350 mA | when measuring line regulation 1 |
| Vcc = 13 V, | Io = 5mA→1 A | when measuring line regulation 1 |
| Vcc = 13 V, | Io = 5mA→500 mA | when measuring load regulation 2 |
| Vcc = 13 V | | when measuring output current capacity 1 |
| Vcc = 13 V | | when measuring output current capacity 2 |

Fig.1 Circuit for measuring output voltage, line regulation, load regulation, and output current capacity

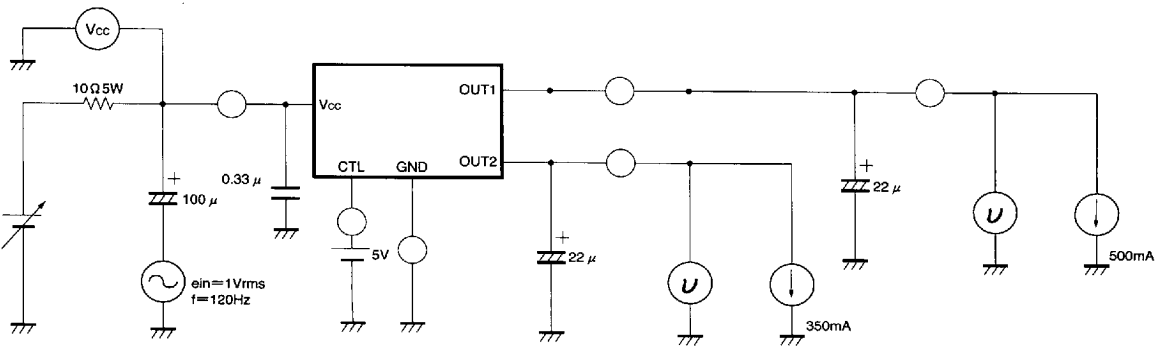

- | | |
|-------------------------|---------------------------------------|
| Vcc = 13 V, Io = 500 mA | when measuring the ripple rejection 1 |
| Vcc = 13 V, Io = 350 mA | when measuring the ripple rejection 2 |

Fig.2 Circuit for measuring ripple rejection

7828999 0018314 894

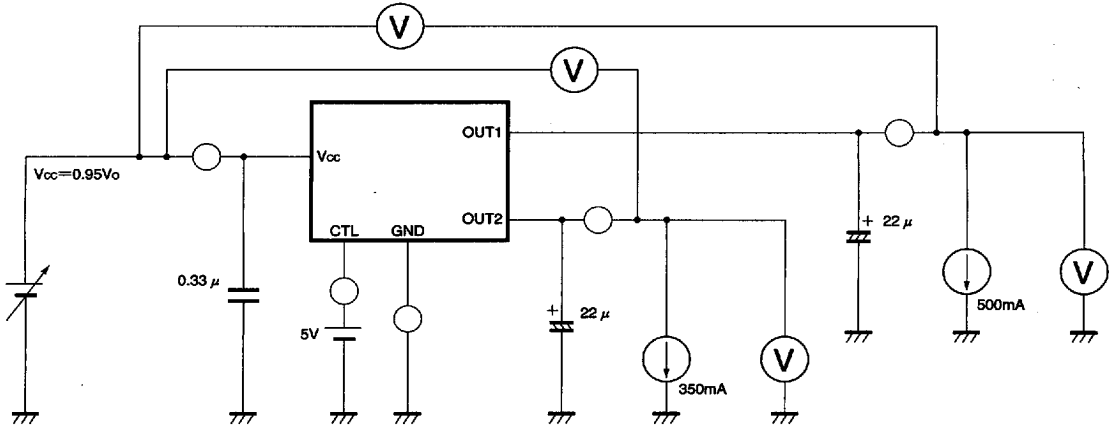
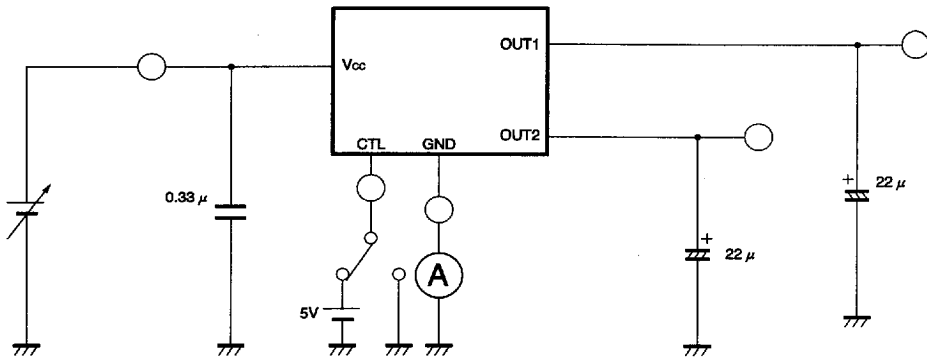

Fig.3 Circuit for measuring drop out voltage



$V_{cc} = 13\text{ V}$, $I_o = 0$ when measuring bias current

Fig.4 Circuit for measuring bias current and power save circuit current

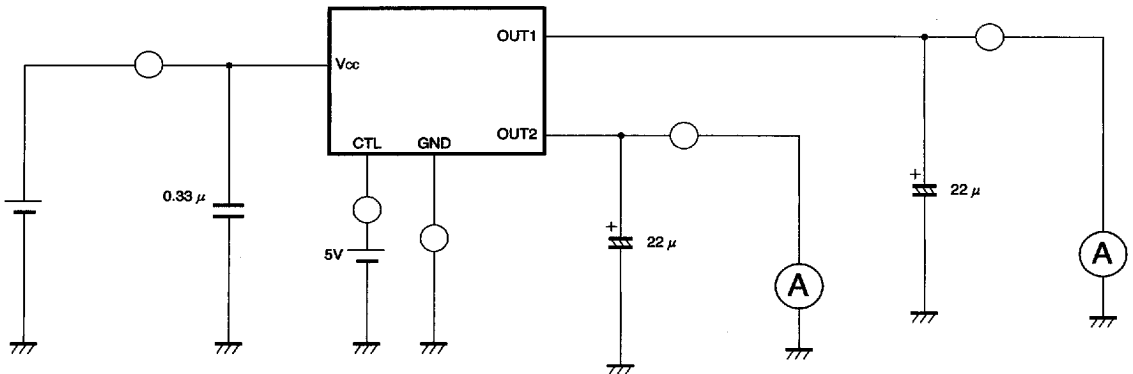

Fig.5 Circuit for measuring output short-circuit current

$V_{CC} = 13V$

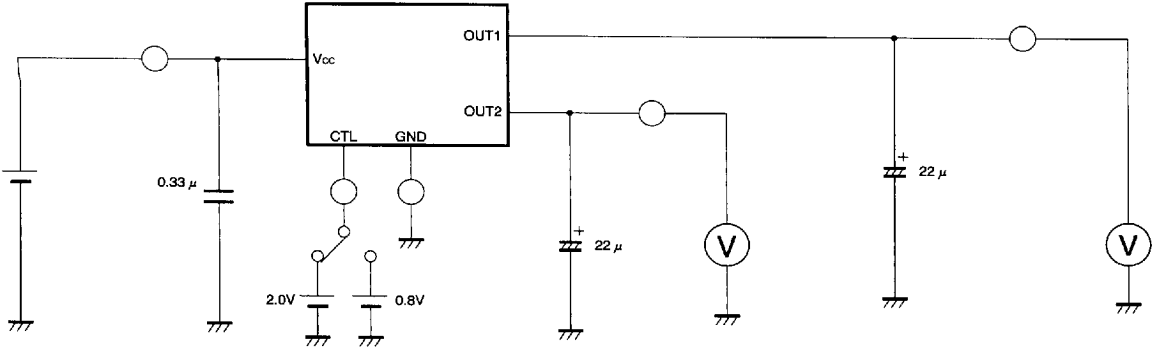

Fig.6 Circuit for measuring mode switching voltage

$V_{CC} = 13V$

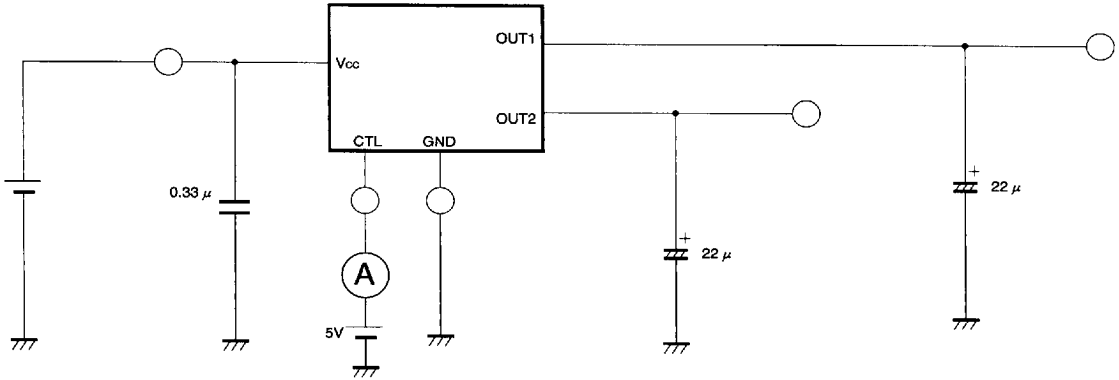
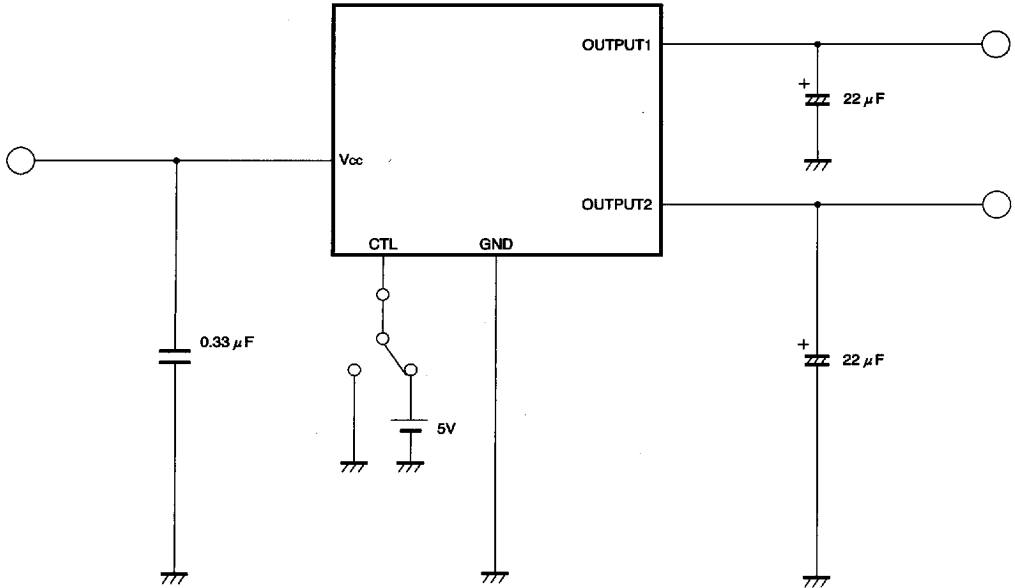

Fig.7 Circuit for measuring input current when HIGH

●Application circuit



● Operation notes

1. Operating power supply

When operating within the proper ranges of power supply voltage and ambient temperature, most circuit functions are guaranteed. Although the rated values of electrical characteristics cannot be absolutely guaranteed, characteristic values do not change drastically within the proper ranges.

2. Power dissipation (Pd)

Refer to the power dissipation characteristics in Fig. 10. If power dissipation exceeds the allowable limit, the functionality of the IC will be degraded (such as reduction of current capacity by increased chip temperature). Make sure to use the IC within the allowable range of power dissipation with a sufficient margin.

3. Preventing oscillation at each output and bypass capacitor

To stop output oscillation, make sure to connect a capacitor between GND and each output pin (capacitance of at least 10 μ F over the whole operating temperature is recommended). Oscillation can occur if capacitance is susceptible to temperature. We recommend using a tantalum electrolytic capacitor with minimal changes in capacitance. Also, output can be further stabilized by connecting a bypass capacitor of about 0.33 μ F between Vcc and GND.

4. Overcurrent protection circuit

An overcurrent protection circuit is installed in each output system, based on the respective output current. This prevents IC destruction due to overcurrent, by limiting the current with a curve shape of "7" in the voltage-current graph. The IC is designed with margins so that current flow will be restricted and latching will be prevented even if a large current suddenly flows through a large capacitor. Note that these protection circuits are only good for preventing damage from sudden accidents. Make sure your design does not cause the protection circuit to operate continuously under transitional conditions (for instance, if output is clamped at 1Vf or higher, short mode circuit operates at 1Vf or lower). Note that the capacitance is negatively correlated with temperature.

5. Thermal protection circuit

A built-in thermal protection circuit prevents thermal damage to the IC. All outputs are turned off when the circuit operates, and revert to the original state when the temperature drops to a certain level.

6. We recommend installing a bypass line in your application if there is a mode where potential difference between each output and input (Vcc) or GND is reversed from the normal state. A reversed mode may cause damage to the IC.

7. Although the quality of this IC is rigorously controlled, the IC may be destroyed when the supply voltage or the operating temperature exceeds their absolute maximum ratings. Because short mode or open mode cannot be specified when the IC is destroyed, be sure to take physical safety measures, such as fusing, if any of the absolute maximum ratings might be exceeded.

●Electrical characteristic curves

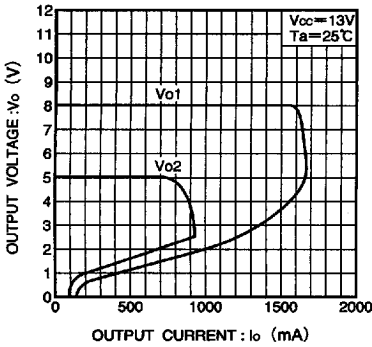

Fig.8 Output current capacity characteristics (typ.)

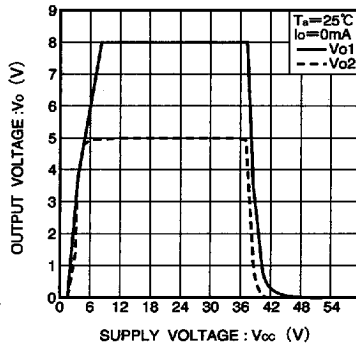

Fig.9 Output voltage vs. supply voltage (typ.)

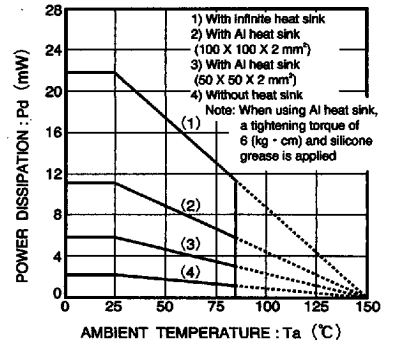

Fig.10 Power derating characteristics

●External dimensions (Units: mm)

