



Z86017

PCMCIA Interface

Product Specification

PS010902-0901





This publication is subject to replacement by a later edition. To determine whether a later edition exists, or to request copies of publications, contact:

ZiLOG Worldwide Headquarters

910 E. Hamilton Avenue
Campbell, CA 95008
Telephone: 408.558.8500
Fax: 408.558.8300
www.ZiLOG.com

Windows is a registered trademark of Microsoft Corporation.

Document Disclaimer

©2001 by ZiLOG, Inc. All rights reserved. Information in this publication concerning the devices, applications, or technology described is intended to suggest possible uses and may be superseded. ZiLOG, INC. DOES NOT ASSUME LIABILITY FOR OR PROVIDE A REPRESENTATION OF ACCURACY OF THE INFORMATION, DEVICES, OR TECHNOLOGY DESCRIBED IN THIS DOCUMENT. ZiLOG ALSO DOES NOT ASSUME LIABILITY FOR INTELLECTUAL PROPERTY INFRINGEMENT RELATED IN ANY MANNER TO USE OF INFORMATION, DEVICES, OR TECHNOLOGY DESCRIBED HEREIN OR OTHERWISE. Devices sold by ZiLOG, Inc. are covered by warranty and limitation of liability provisions appearing in the ZiLOG, Inc. Terms and Conditions of Sale. ZiLOG, Inc. makes no warranty of merchantability or fitness for any purpose Except with the express written approval of ZiLOG, use of information, devices, or technology as critical components of life support systems is not authorized. No licenses are conveyed, implicitly or otherwise, by this document under any intellectual property rights.



Table of Contents

Features	1
General Description	1
Pin Description	7
Pin Identification	8
Pin Functions	11
Absolute Maximum Ratings	16
Standard Test Conditions	16
DC Specifications	17
DC Electrical Characteristics	18
Internal Attribute Memory Timing	19
EEPROM Master Timing	27
Slave Interface Timing, Serial Bus	28
PCMCIA I/O Timing	29
Package Information	30
Ordering Information	30

List of Figures

Figure 1. Z86017 Functional Block Diagram	3
Figure 2. Connection Block Diagram	4
Figure 3. Serial Interface Diagram	5
Figure 4. Attribute and Configuration Memory Diagram	6
Figure 5. Z86017 100-Pin VQFP Package	7
Figure 6. Test Load Diagram	16
Figure 7. PCMCIA Read Memory Timing, No Wait States	22
Figure 8. PCMCIA Read Memory Timing, Wait State Enabled	23
Figure 9. PCMCIA Memory Timing, Wait State Enabled	24
Figure 10. PCMCIA Memory Write Timing, No Wait States	25
Figure 11. SKEW Timing between PCMCIA and ATA Bus	26
Figure 12. Write EEPROM Timing	27
Figure 13. Read EEPROM Timing	27
Figure 14. Write Slave Timing	28



Figure 15. Read Slave Timing	28
Figure 16. I/O Write Timing	29
Figure 17. I/O Read Timing	29
Figure 18. 100-Lead Plastic Very Small Quad Flatpack (VQFP)	30

List of Tables

Table 1. Power Connections	2
Table 2. Pin Identification	8
Table 3. Absolute Maximum Rating	16
Table 4. Absolute Rating Limits	17
Table 5. 3-Volt Operating Conditions	17
Table 6. 5-Volt Operating Conditions	17
Table 7. DC Electrical Characteristics	18
Table 8. Internal Attribute Memory Timing	19
Table 9. PCMCIA Memory Write and Read Timing	19
Table 10. I/O Read Timing Specification	20
Table 11. I/O Write Timing Specification	21
Table 12. SKEW Timing between PCMCIA and ATA Bus	25
Table 13. Serial Interface Timing	26



Z86017 PCMCIA Interface

Features

- 256 Bytes of Attribute Memory
- Five Configuration Registers
- Direct Memory Access (DMA) Support
- EEPROM Sequencer Circuitry for Program Loading From a Local EEPROM, Master Mode
- Serial Peripheral Interface (SPI) Circuitry Allows Control Through the Local Micro-processor, Slave Mode
- PCMCIA to I/O Peripheral
- PCMCIA to ATA/IDE Translation
- ATA/IDE to ATA/IDF Mapping, Pass Through Mode
- Operates from a 3 V to 5.5V Power Supply
- Conforms to PCMCIA Standards
- Low Power Dissipation:
 - 12 mW @ 3V
 - 25 mW @ 5V
 - 250 mW @ 5V (in power down mode)
- 100-Pin Low Profile VQFP Package
- Advanced 1.2 Micron CMOS Process

General Description

The Z86017 is a general-purpose PCMCIA adaptor chip used on the card side of the interface. The Z86017 easily configures to all types of memory and I/O mapped peripheral hardware. Mapping is performed from the I/O and Memory mapped PCMCIA to local peripheral ICs that support Ethernet controllers, UARTs,



modems, printer ports, solid state memory, rotating disk memory, and other peripheral devices.

The Z86017 can be used in a stand-alone configuration without the use of a local processor by providing all of the attribute memory, CCRs, range, interrupt types through a serial EEPROM. The serial EEPROM is read automatically using an internal EEPROM sequencer. The Z86017 can also be configured through a local processor for use on intelligent controller systems.

Power connections follow conventional descriptions below:

Table 1. Power Connections

Connection	Circuit	Device
Power	V_{CC}	V_{DD}
Ground	GND	V_{SS}

The Z86017 provides for the PCMCIA to IDE translation, IDE to IDE mapping, or PCMCIA to three general-purpose maps (Figure 1).

Address Mapping Circuit

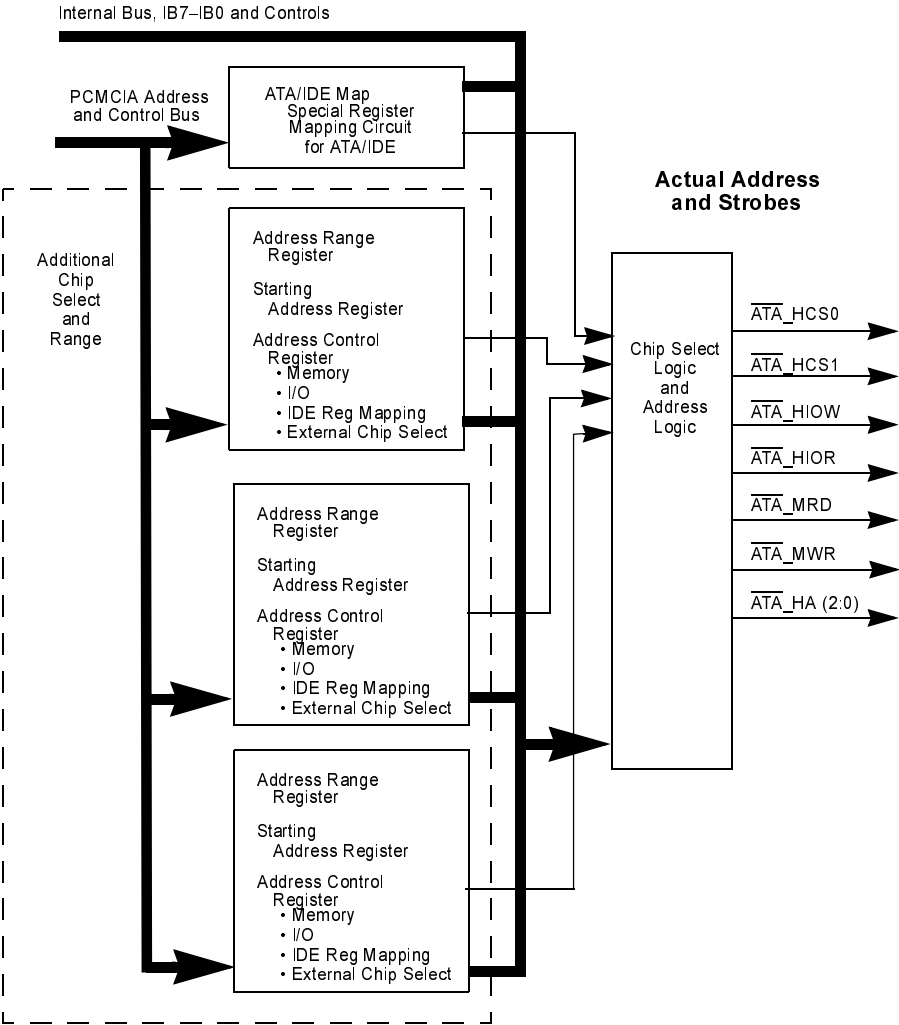

Figure 1. Z86017 Functional Block Diagram

The local processor connects to the Z86017 through the serial interface or can be programmed through an external EEPROM (Figure 2). If the external EEPROM does not have the valid signature inside, the Z86017 acknowledges all selects on the PCMCIA interface.

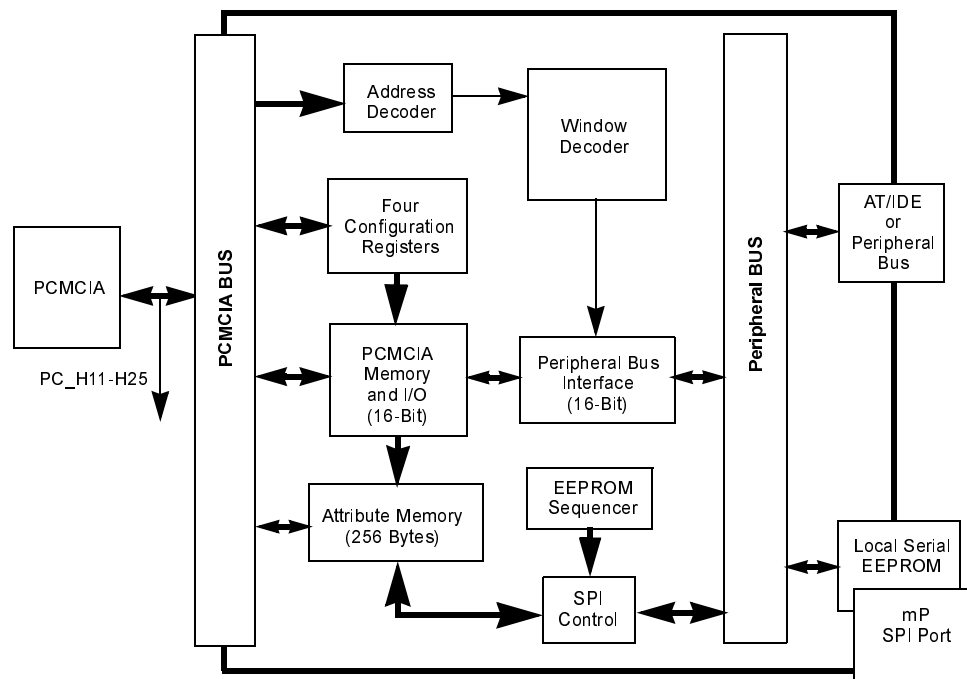

Figure 2. Connection Block Diagram

The Z86017 IC can become an EEPROM interface master or a local processor slave. There are two independent sequencer circuits in the IC to provide for the master and slave operation (Figure 3).

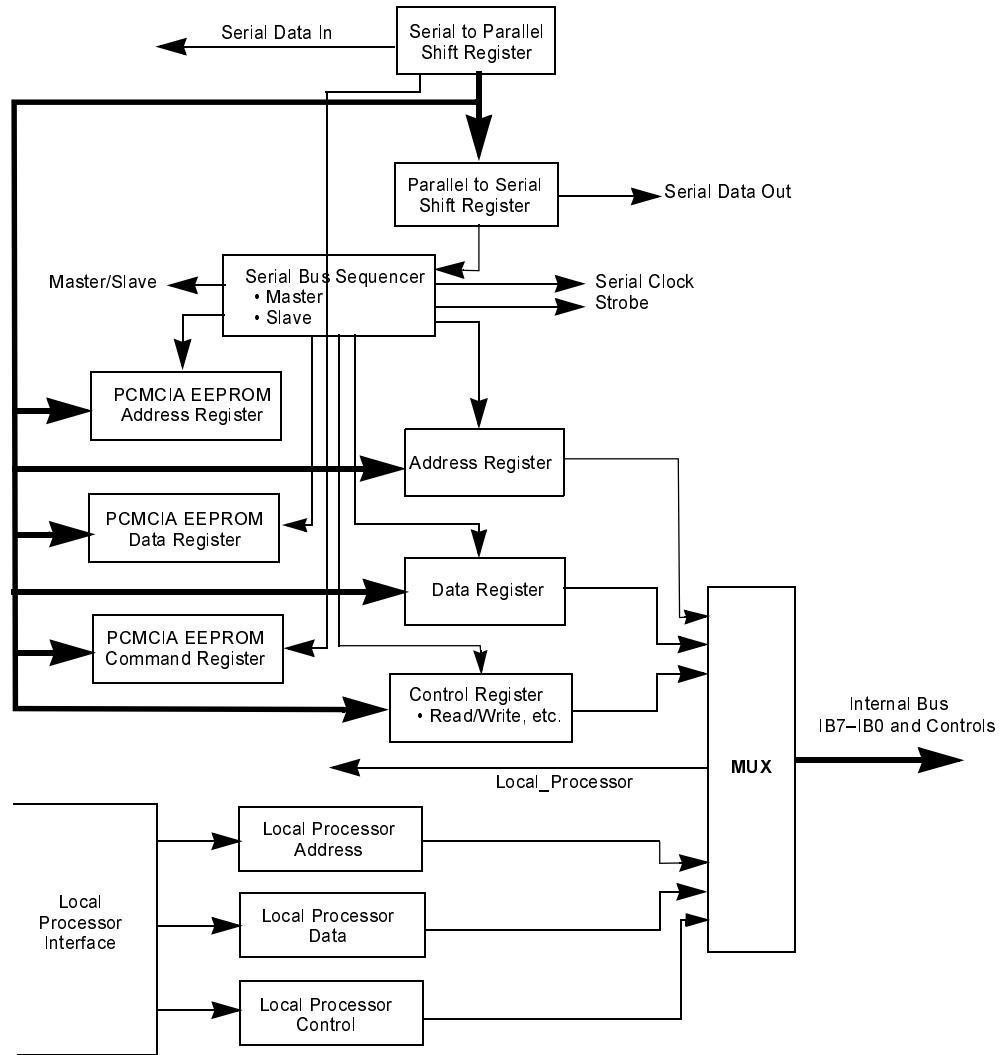

Figure 3. Serial Interface Diagram

The Z86017 IC provides the five standard PCMCIA registers. Three additional registers have been added to provide for remote programming of the EEPROM (Figure 4).

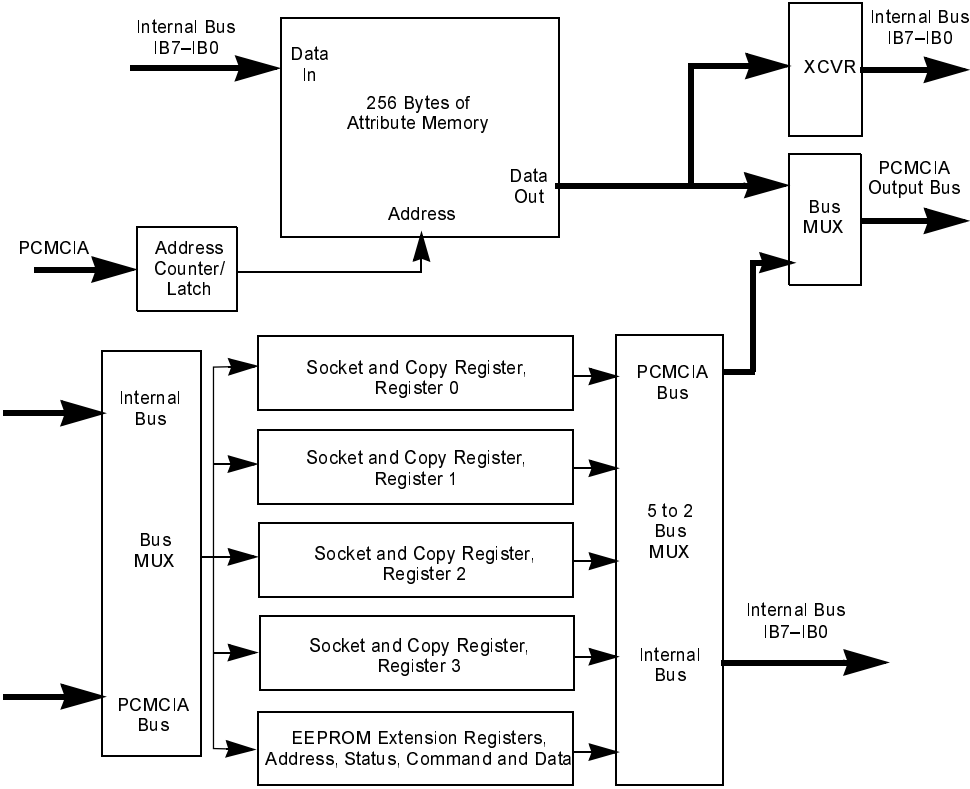

Figure 4. Attribute and Configuration Memory Diagram

Pin Description

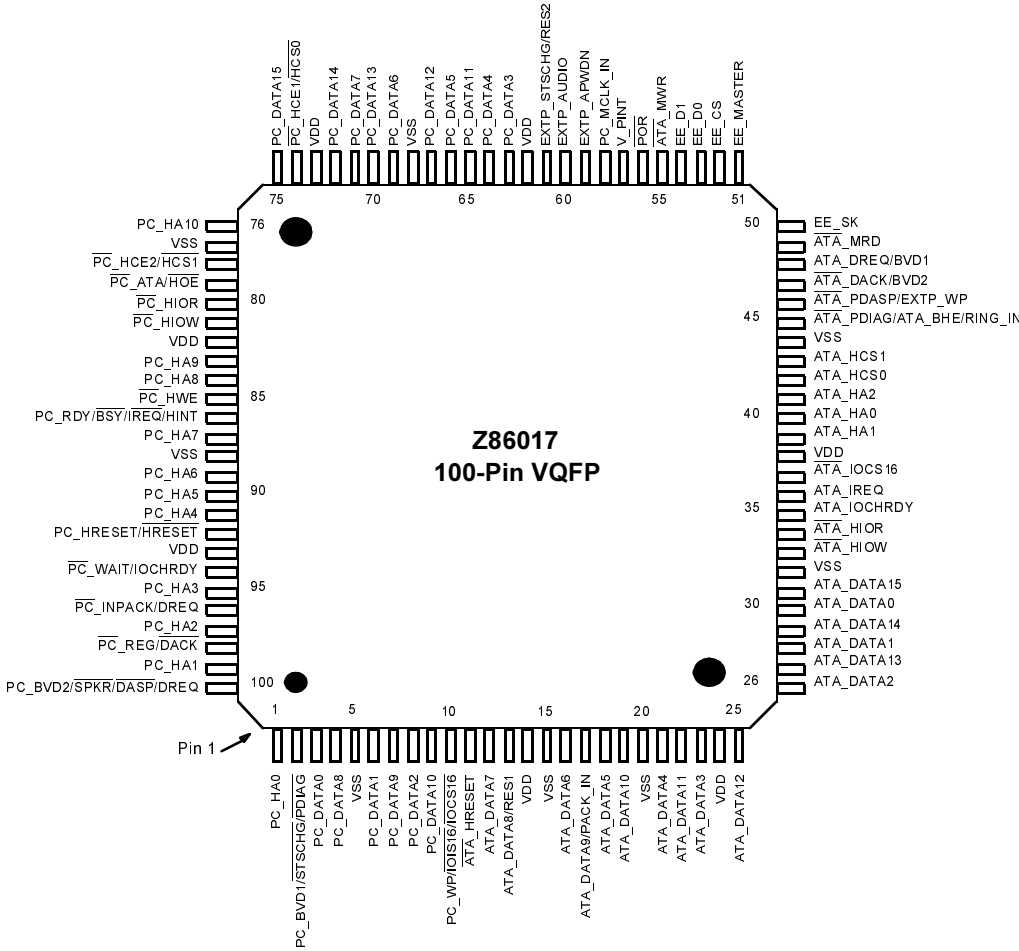

Figure 5. Z86017 100-Pin VQFP Package



Pin Identification

Table 2. Pin Identification

Pin No.	Name	Description
1	PC_HA0	PCMCIA Address, Bit 0
2	$\overline{\text{PC_STSCHG}}/\overline{\text{BVD1}}/\overline{\text{PDIAG}}$	PCMCIA Status Change or BVD1 or ATA PDIAG Bit
3	PC_DATA0	PCMCIA Data, Bit 0
4	PC_DATA8	PCMCIA Data, Bit 8
5	VSS	Ground
6	PC_DATA1	PCMCIA Data, Bit 1
7	PC_DATA9	PCMCIA Data, Bit 9
8	PC_DATA2	PCMCIA Data, Bit 2
9	PC_DATA10	PCMCIA Data, Bit 10
10	$\overline{\text{PC_WP}}/\overline{\text{IOIS16}}/\overline{\text{IOCS16}}$	PCMCIA I/O Is 16-Bit Transfers or WRITE PROTECT
11	$\overline{\text{ATA_HRESET}}$	AT Host RESET
12	ATA_DATA7	AT Host Data, Bit 7
13	ATA_DATA8/RES 1	AT Host Data, Bit 8 or Reserved Bit 1 in I/O CCR4
14	VDD	Supply Voltage
15	VSS	Ground
16	ATA_DATA6	AT Host Data, Bit 6
17	ATA_DATA9	AT Host Data, Bit 9 or Packet into CCR4
18	ATA_DATA5	AT Host Data, Bit 5
19	ATA-DATA10	AT Host Data, Bit 10
20	VSS	Ground
21	ATA_DATA4	AT Host Data, Bit 4
22	ATA_DATA11	AT Host Data, Bit 11
23	ATA_DATA3	AT Host Data, Bit 3
24	VDD	Supply Voltage
25	ATA-DATA12	AT Host Data, Bit 12
26	ATA DATA2	AT Host Data, Bit 2



Table 2. Pin Identification (Continued)

Pin No.	Name	Description
27	ATA-DATA13	AT Host Data, Bit 13
28	ATA DATA1	AT Host Data, Bit 1
29	ATA-DATA14	AT Host Data, Bit 14
30	ATA_DATA0	AT Host Data, Bit 0
31	ATA-DATA15	AT Host Data, Bit 15
32	VSS	Ground
33	$\overline{\text{ATA_HIOW}}$	AT Host I/O Write Strobe
34	$\overline{\text{ATA_HIOR}}$	AT Host I/O Read Strobe
35	ATA_IOCHRDY	AT Host I/O Channel Ready
36	ATA_IREQ	AT Host Interrupt Request
37	$\overline{\text{ATA_IOIS16}}$	AT Host I/O Is 16 Bits Wide
38	VDD	Supply Voltage
39	ATA_HA1	AT Host Address, Bit 1
40	ATA_HA0	AT Host Address, Bit 0
41	ATA_HA2	AT Host Address, Bit 2
42	ATA_HCS0	AT Host Chip Select 0
43	ATA_HCS1	AT Host Chip Select 1
44	VSS	Ground
45	$\overline{\text{ATA_PDIAG/ATA_BHE}}$ /Ring-in	PDIAG I/O or Byte High Enable or Ring-in to CCR4
46	$\overline{\text{ATA_PDASP/EXTP_WP}}$	PDASP I/O or Write Protect In
47	$\overline{\text{ATA_DACK/BVD2}}$	AT Host DMA Acknowledge or BVD2 input
48	ATA_DREQ	AT Host DMA Request
49	$\overline{\text{ATA_MRD}}$	AT Host Memory Read Strobe
50	EE-SK_EPROM	Data Clock
51	EE-MASTER	EEPROM Is Master
52	EE-CS	EPROM Data Chip Select
53	EE-DO	EPROM Data Out
54	EE-DI	EPROM Data In
55	$\overline{\text{ATA_MWR}}$	AT Host Memory Write Strobe



Table 2. Pin Identification (Continued)

Pin No.	Name	Description
56	POR	Power-On Reset
57	M_PINT	Local Processor Interrupt
58	PC_MCLK_IN	Master Clock In
59	EXTP_PWDN	Power Down Output
60	EXTP_AUDIO	Audio Input
61	EXTP_STSCHG	Status Change Input
62	VDD	Supply Voltage
63	PC_DATA3	PCMCIA Data, Bit 3
64	PC_DATA4	PCMCIA Data, Bit 4
65	PC_DATA11	PCMCIA Data, Bit 11
66	PC_DATA5	PCMCIA Data, Bit 5
67	PC-DATA12	PCMCIA Data, Bit 12
68	VSS	Ground
69	PC_DATA6	PCMCIA Data, Bit 6
70	PC_DATA13	PCMCIA Data, Bit 13
71	PC_DATA7	PCMCIA Data, Bit 7
72	PC-DATA14	PCMCIA Data, Bit 14
73	VDD	Supply Voltage
74	$\overline{\text{PC_HCE1/HCS0}}$	PCMCIA Chip Select 0
75	PC-DATA15	PCMCIA Data, Bit 15
76	PC-HA10	PCMCIA Address, Bit 10
77	VSS	Ground
78	$\overline{\text{PC_HCE2/HCS1}}$	PCMCIA Chip Select 1
79	$\overline{\text{PC_ATA/HOE}}$	PCMCIA Output Enable
80	$\overline{\text{PC_HIOR}}$	PCMCIA I/O Read Strobe
81	$\overline{\text{PC_HIOW}}$	PCMCIA I/O Write Strobe
82	VDD	Supply Voltage
83	PC_HA9	PCMCIA Address, Bit 9
84	PC_HA8	PCMCIA Address, Bit 8
85	$\overline{\text{PC_HWE}}$	PCMCIA WRITE Strobe



Table 2. Pin Identification (Continued)

Pin No.	Name	Description
86	PC_RDY/ $\overline{\text{BSY}}$ $\overline{\text{HIREQ}}$ / $\overline{\text{HINT}}$	PCMCIA Interrupt Request or PCMCIA Ready/Busy
87	PC_HA7	PCMCIA Address, Bit 7
88	VSS	Ground
89	PC_HA6	PCMCIA Address, Bit 6
90	PC_HA5	PCMCIA Address, Bit 5
91	PC_HA4	PCMCIA Address, Bit 4
92	PC_HRESET/ $\overline{\text{HRESET}}$	PCMCIA Reset
93	V _{DD}	Supply Voltage
94	$\overline{\text{PC_WAIT}}$ / $\overline{\text{IOCHRDY}}$	PCMCIA I/O Channel Ready
95	PC_HA3	PCMCIA Address, Bit 3
96	$\overline{\text{PC_INPACK}}$ / $\overline{\text{DREQ}}$	PCMCIA Input Acknowledge
97	PC_HA2	PCMCIA Address, Bit 2
98	$\overline{\text{PC_REG}}$ / $\overline{\text{DACK}}$	PCMCIA Register Signal
99	PC_HA1	PCMCIA Address, Bit 1
100	PC_SPKR/ $\overline{\text{DASP}}$ / $\overline{\text{DREQ}}$	IDE DASP Pin or PCMCIA Speaker

Pin Functions

- $\overline{\text{PC_HCE1}}$ / $\overline{\text{HCS0}}$, (Input, Schmitt-Triggered, 100 k Ω Pull-Up):
 - PCMCIA Mode: Host Card Enable 1 (active Low). Enables even or odd numbered data bytes onto the “PC-DATA (7-0)” Bus.
 - ATA Mode: Host Chip Select 0 (active Low).
- $\overline{\text{PC_HCE2}}$ / $\overline{\text{HCS1}}$, (Input, Schmitt-Triggered, 100 k Ω Pull-Up):
 - PCMCIA Mode: Host Card Enable 2 (active Low). Enables odd numbered data bytes onto the “PC-DATA (15-8)” Bus.
 - ATA Mode: Host Chip Select 1 (active Low).
- PC-HA (10-3)(Input, Schmitt-Triggered):
 - PCMCIA Mode: Host Address Lines, Bits 10-3.
 - ATA Mode: Not used.



- PC-HA (2-0)(Input, Schmitt-Triggered):
 - PCMCIA Mode: Host address Lines, Bits 2-0.
 - ATA Mode: Host address Lines, Bits 2-0.
- $\overline{PC_SPKRUDASP/DREQ}$ (Input/Output, Tri-Stated, 8mA):
 - PCMCIA Mode: Speaker Output (active Low). This signal is the opposite polarity of the “EXTP_AUDIO” input signal and the extended special function bus in PCMCIA Mode. If configured in the general-purpose address recognition registers, this signal is DMA request, active Low, when ATA_DREQ is asserted active High.
 - ATA Mode: Slave present bit when in ATA mode or when enabled in PCMCIA mode.
- $\overline{PC_HIOR}$ (Input, Schmitt-Triggered, 100 k Ω Pull-Up):
 - PCMCIA Mode: Host Input/Output Read Strobe (active Low). In PCMCIA I/O Mode, this is the Input/Output Read Strobe.
 - ATA Mode: Input/Output Read Strobe (active Low).
- $\overline{PC_HIOW}$ (Input, Schmitt-Triggered, 100 k Ω Pull-Up):
 - PCMCIA Mode: Host Input/Output Write Strobe (active Low). Mode, this is the Input/ Output Write Strobe.
 - ATA Mode: Input/Output Write Strobe (active Low).
- PC_RDY/BSY/ \overline{IREQ} /HINT (Output, 8mA):
 - PCMCIA Mode: Ready/Busy (active High) or \overline{IREQ} (active Low). In PCMCIA Common Memory Mode, this signal is Ready/Busy. This signal is asserted BUSY by the Reset logic. In PCMCIA I/O Mode, this signal is \overline{IREQ} .
 - ATA Mode: Host Interrupt (active High). This signal sends an interrupt to the host when enabled.
- PC_WP/ $\overline{IOIS16}$ / $\overline{IOCS16}$ (Output, Tri-Stated, 8mA):
 - PCMCIA Mode: Write Protect (active High) or I/O is 16 bits (active Low). In PCMCIA Common Memory Mode, this signal is write protect. In PCMCIA I/O Mode, this signal is I/O and 16 bits. This signal indicates a 16-bit data transfer is active on the PCMCIA Bus.
 - ATA Mode: I/O Chip Select 16 bits (active Low). Indicates a 16-bit transfer is active on the bus.
- PC_WAIT/AOCHRDY/AOCHRDY(Output, Tri-State, 8mA):
 - PCMCIA Mode: Wait (active High). Inserts wait states when held active and the chip is being selected in I/O or Memory Mode.
 - ATA Mode: Wait (active High). Inserts wait states when held active and the chip is being selected.



- $\overline{\text{PC_HRESET}}$ /HRESET (*Input, Schmitt-Triggered, 100 k Ω Pull-Up*):
 - PCMCIA Mode: Host Reset (active High). Host input reset signal.
 - ATA Mode: Host Reset (active Low). Host input reset signal.
- $\overline{\text{PC_INPACK}}$ /DREQ (*Output, Tri-Stated, 8 mA*):
 - PCMCIA Mode: Input Acknowledge (active Low). This signal is asserted by the peripheral to drive data and/or command/status on the data bus when the chip is selected.
 - ATA Mode: Data request (active High). This signal is issued during DMA data transfers on the data bus as defined in ATA.
- $\overline{\text{PC_REG}}$ / $\overline{\text{DACK}}$ (*Input, Schmitt-Triggered, 100 k Ω Pull-Up*):
 - PCMCIA Mode: Register Bit (active Low). This signal is asserted when the host selects I/O Memory or Attribute Memory.
 - ATA Mode: Data Acknowledge (active Low). This signal is issued during DMA data transfers on the data bus as defined in ATA.
- $\overline{\text{PC_STSCHG}}$ / $\overline{\text{PDIAG}}$ (*Input/Output, 8 mA*):
 - PCMCIA Mode: Status Change (active Low). This signal is used to indicate changes in the Card Configuration Registers.
 - ATA Mode: Passed diagnostics (active Low).
- $\overline{\text{PC_ATA}}$ / $\overline{\text{OE}}$ (*Input, Schmitt-Triggered, 100 k Ω Pull-Down*):
 - PCMCIA Mode: Output Enable (active Low).
 - ATA Mode: AT Mode (active Low). This signal indicates AT Mode when pulled Low on a Power-On Reset.
- $\overline{\text{PC_WE}}$ (*Input, Schmitt-Triggered, 100 k Ω Pull-Up*):
 - PCMCIA Mode: Write enable (active Low).
 - ATA Mode: Not used.
- PC DATA (15-0) (*Input/Output, Tri-Stated, 8 mA*):
 - PCMCIA Mode: Host Data Lines, 16 bits.
 - ATA Mode: Host Data Lines, 16 bits.
- /POR (*Input, Schmitt-Triggered, 100 k Ω Pull-Up*):
 - Power-On Reset (active Low). Local power on reset signal.
- EE_DO (Output, 2mA):
 - EEPROM Data Out (active High). This signal indicates serial data is valid during “EE_SK” edge. In Master Mode or Slave Mode, this signal is an output.
- EE-SK (*Input/Output, 2 mA*):
 - EEPROM Data Clock (active High). This signal is an output in Master Mode. In Slave Mode, this signal is an input.



- **EE-CS (Input/output, 2 mA):**
EPROM Data Chip Select (active High). This signal is an output in Master Mode. In Slave Mode, this signal is an input.
- **EE_DI (Input, Schmitt-Triggered, 100 kΩ Pull-Up):**
EPROM Data Input (active High). This signal is an input in Master Mode or Slave Mode.
- **PC_MCLK_IN Input, Schmitt-Triggered):**
Master Clock Input. This is the input clock signal used to generate all internal timing when reading the EEPROM using the internal EEPROM sequencer. It is also used to generate internal timing for Ready.
- **EXTP_STSCHG (Input, Schmitt-Triggered, 100 kΩ Pull-Up):**
Status Change Input (active High). This signal outputs the value of the status changed line on the PCMCIA bus if enabled in the CCR Register.
- **EXTP_AUDIO (Input, Schmitt-Triggered, 100 kΩ Pull-Up):**
Audio Input (active High). This signal is the input signal which reflects the audio output. This signal is active High, whereas the Speaker Output on the PCMCIA Bus is active Low.
- **EXTP_PWDN (Output, 2 mA):**
Power Down Output (active High). This signal reflects the state of the Power Down Bit in the CCR.
- **$\overline{\text{ATA_MRD}}$ (Output, 2mA):**
External Memory Read Strobe (active Low).
- **$\overline{\text{ATA_MWR}}$ (Output, 2 mA):**
External Memory Write Strobe (active Low).
- **$\overline{\text{ATA_PDASP/EXTP_WP}}$ (Input/Output, Tri-Stated, 2 mA):**
Local AT bus side PDASP signal controlled by internal bits ZEN_EXT_PDASP (Input) or ZEN_INPUTT_PDASP (Output). When configured as write protect, this signal stops all Write Strokes on the local AT Bus.
- **$\overline{\text{ATA_PDIAG/ATA_BHE}}$ (Input/Output, Tri-Stated, 2 mA):**
Local AT bus side PDIAG signal controlled by internal bits ZEN_EXT_PDIAG (Input) or ZEN_INPUTT_PDIAG (Output). When configured as High Byte Enable for memory boards, “ATA_BHE” indicates a High Byte available or High Byte requested on the Local AT Bus.
- **ATA_IOCHRDY (Input, Schmitt-Triggered, 100 kΩ Pull-Up):**
I/O Channel Ready (active High). This input signal indicates the I/O Channel on the Local AT Bus is ready.
- **$\overline{\text{ATA_IOIS16}}$ (Input, Schmitt-Triggered, 100 kΩ Pull-Up):**
I/O Channel is 16 bits (active Low). This input signal indicates the I/O Channel on the Local AT bus is 16 bits wide.



- **EE-MASTER** (*Input, Schmitt-Triggered, 100 kΩ Pull-Up*):
EEPROM Master Interface Enabled (active High). When this input is set High, an EEPROM is present. When this signal is set Low, no EEPROM is present.
- **$\overline{\text{ATA_HCS0}}$** (*Output, 2 mA*):
IDE/ATA Mode: AT Host Chip Select 0 (active Low). This signal is used to select the IDE interface chip as standard IDE format.
Local Bus Mode: Chip Select 0 (active Low). This signal is used to connect as a chip select for an external peripheral device as defined by the address range and offset register definition.
- **$\overline{\text{ATA_HCS1}}$** (*Output, 2 mA*):
IDE/ATA Mode: AT Host Chip Select 1 (active Low). This signal is used to select the IDE interface chip as standard IDE format.
Local Bus Mode: Chip Select 1 (active Low). This signal is used to connect as a chip select for an external peripheral device as defined by the address range and offset register definition.
- **ATA_HA (2-0)** (*Output, 2 mA*):
IDE/ATA Mode: AT Host Address Lines, Bits 2-0. These lines are used to address the IDE interface chip task register file as standard IDE format.
Local Bus Mode: Address Lines, Bits 2-0. These lower three bits offset from starting address.
- **ATA_IREQ** (*Input, Schmitt-Triggered*):
IDE/ATA Mode: AT Host Interrupt Request (active High).
Local Bus Mode: Interrupt Request (active High).
- **$\overline{\text{ATA_HIOR}}$** (*Output, 2mA*):
IDE/ATA Mode: AT Host I/O Read Strobe (active Low).
Local Bus Mode: I/O Read Strobe or Memory Read Strobe or Data Strobe (active Low). The function of this signal depends on the configuration.
- **$\overline{\text{ATA_HIOW}}$** (*Output, 2 mA*):
IDE/ATA Mode: AT Host I/O Write Strobe (active Low).
Local Bus Mode: I/O Write Strobe or Memory Write Strobe or Read/Write Data Enable (active Low). The function of this signal depends on the configuration.
- **$\overline{\text{ATA_HRESET}}$** (*Output, 2 mA*):
IDE/ATA Mode: AT Host Reset (active High or Low). This signal is the reset output to the IDE controller.
Local Bus Mode: AT Host Reset (active High or Low). This signal is the reset output to the peripheral device if PCMCIA signal is active.
- **ATA_DATA (15-0)** (*Input/Output, Tri-Stated, 2 mA*):
IDE/ATA Mode: Host Data Bus, Bits 15-0.
Local Bus Mode: Peripheral Data Bus, Bits 15-0.



- **ATA_DREQ/BVD1** (*Input, Schmitt-Triggered*):
IDE/ATA Mode: AT Host DMA Request (active High).
Local Bus Mode: Peripheral Bus DMA Request (active High). When PCMCIA is connected, this signal is asserted through the “PC SPKR” pin on the PCMCIA interface.
- **$\overline{\text{ATA_DACK/BVD2}}$** (*Output, 2 mA*):
IDE/ATA Mode: AT Host DMA Acknowledge (active Low).
Local Bus Mode: Peripheral Bus DMA Acknowledge (active Low). DMA acknowledge is generated by Z86017 whenever DMA acknowledge is configured in the PCMCIA address registers and the address corresponds to the DMA address.
- **M_PINT** (*Output, Tri-stated*):
Microprocessor Interrupt (active High). This signal is the interrupt to local microprocessor.
- **V_{SS}** (*Input*):
Digital Ground
- **V_{DD}** (*Input*):
Digital Supply Voltage

Absolute Maximum Ratings

Table 3. Absolute Maximum Rating

Symbol	Description	Min	Max	Unit
VCC	Supply Voltage ¹	-0.3	+7.0	V
TSTG	Storage Temperature	-65	+150	C
TA	Operating Ambient Temperature	Note ²	Note ²	C

1. Voltages on all pins with respect to GND.

2. See Ordering Information

Stresses greater than those listed under Absolute Maximum Ratings may cause permanent damage to the device. This rating is a stress rating only; operation of the device at any condition above those indicated in the operational sections of these specifications is not implied. Exposure to absolute maximum rating conditions for an extended period may affect device reliability.

Standard Test Conditions

The characteristics listed below apply for standard test conditions as noted (Test Load Diagram).

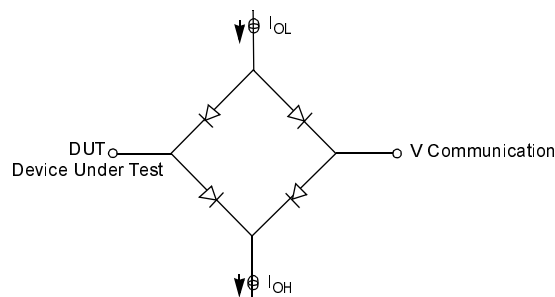

Figure 6. Test Load Diagram

DC Specifications

Table 4. Absolute Rating Limits

Parameter	Symbol	Unit	Min Value	Max Value
Supply Voltage	V_{DD}	(V)	-0.5	7.0
Input Voltage	V_i	(V)	-0.5	$V_{DD} + 0.5$
Output Voltage	V_o	(V)	-0.5	$V_{DD} + 0.5$
Storage Temperature	T_{stg}	(C)	-40	+125
Temperature Under Bias	T_{bias}	(C)	-25	+85

Table 5. 3-Volt Operating Conditions

Parameter	Symbol	Unit	Min Value	Max Value
Supply Voltage	V_{DD}	(V)	3.0	5.5
Input High Voltage for TTL Inputs	V_{IH}	(V)	2.4	V_{DD}
Input Low Voltage for TTL Inputs	V_{IL}	(V)	-0.5	0.6
Operating Temperature	T_a	(C)	0	70



Table 6. 5-Volt Operating Conditions

Parameter	Symbol	Unit	Min Value	Max Value
Supply Voltage	V_{DD}	(V)	4.5	5.5
Input High Voltage for TTL Inputs	V_{IH}	(V)	2.4	V_{DD}
Input Low Voltage for TTL Inputs	V_{IL}	(V)	-0.5	0.8
Operating Temperature	T_a	(C)	0	70

DC Electrical Characteristics

Table 7. DC Electrical Characteristics

Parameter	Symbol	Unit	Min Value	Max Value
Power Supply Current	I_{DDs} ¹	(mA)		5 (5V) 4 (3V)
Output High Voltage	V_{OH} ($I_{OH} = -2mA$)	(V)	2.4	V_{DD}
Output Low Voltage	V_{OL} $I_{OL} = 2 mA$	(V)		0.4
Input Leakage Current	I_L $V_i \leq V_{DD}$	(mA)	-10	10
Power Dissipation	P_{max}	mW μW		25 (5V) 12 (3V) 250 μW (Power down mode)
Input Capacitance	C_i	(pf)		8 pf

1. I_{DDs} is specified at 1 MHz on PCMCLKIN and V_{DD} on EESK



Internal Attribute Memory Timing

Table 8. Internal Attribute Memory Timing

Item	Symbol	Min	Max	Units
Read Cycle Time	tc(R)	300		nS
Address Access Time	ta(A)		300	nS
Card Enable Time	ta(CE)		300	nS
Output Enable Access Time	ta(OE)		150	nS
Output Disable Time from CE	tdis(CE)		100	nS
Output disable time from OE	tdis(OE)		100	nS
Output enable time from CE	ten CE)	5		nS
Output enable time from OE	ten(OE)	5		nS
Data Valid from ADD Change	tv(A)	0		nS
Address Setup Time	Tsu(A)	30		nS
Address Hold Time	th(A)	20		nS
Card Enable Setup Time	tsu(CE)	0		nS
Card Enable Hold Time	th(CE)	20		nS
Wait Valid from OE	tv(WT-OE)		35	nS
Wait Pulse Width	tw(WT)		12	μS
Data Setup for wait Released	tv(WT)	0		nS

Table 9. PCMCIA Memory Write and Read Timing

Speed Version	Symbol	200nS		150 nS		100 nS	
		Min	Max	Min	Max	Min	Max
Write Cycle Time	tc(W)	200		150		100	
Write Pulse Width	tw(WE)	120		80		60	
Address Setup Time	tsu(A)	20		20		10	
Address Setup Time for WE	tsu(A-WEH)	140		100		70	
Card Enable Setup Time for WE	tsu(CE-WEH)	140		100		70	



Table 9. PCMCIA Memory Write and Read Timing (Continued)

Speed Version	Symbol	200nS		150 nS		100 nS	
		Min	Max	Min	Max	Min	Max
Data Setup Time for WE	tsu (D-WEH)	60		50		40	
Data Hold Time	th(D)	30		20		15	
Write Recover Time	trec(WE)	30		20		15	
Output Disable Time from WE	tdis(WE)		90		75		50
Output Disable Time from OE	tdis(OE)		90		75		50
Output Setup from WE	ten(WE)	5		5		5	
Output Enable Setup from WE	tsu(OE-WE)	10		10		10	
Card Enable Hold from WE	th(OE-WE)	10		10		10	
Card Enable Setup Time	tsu(OE-WE)	0		0		0	
Card Enable Hold Time	th(CE)	20		20		15	
Wait Valid from WE	tv(WT-WE)		35		35		35
Wait Pulse Width	tw(WT)		12us		12μS		12 μS
WE high from Wait Released	tv(WT)	0		0		0	

Table 10. I/O Read Timing Specification

Item	Symbol	Min	Max	Units
Data Delay after IORD	td(IORD)		100	nS
Data Hold following IORD	th(IORD)	0		nS
LORD Width Time	tw(IORD)	165		nS
Address Setup before IORD	tsuA(IORD)	70		nS
Address Hold Following IORD	thA(IORD)	20		nS
CE Setup before IORD	tsuCE(IORD)	5		nS
CE Hold Following IORD	thCE(IORD)	20		nS
REG Setup before IORD	tsuREG(IORD)	5		nS

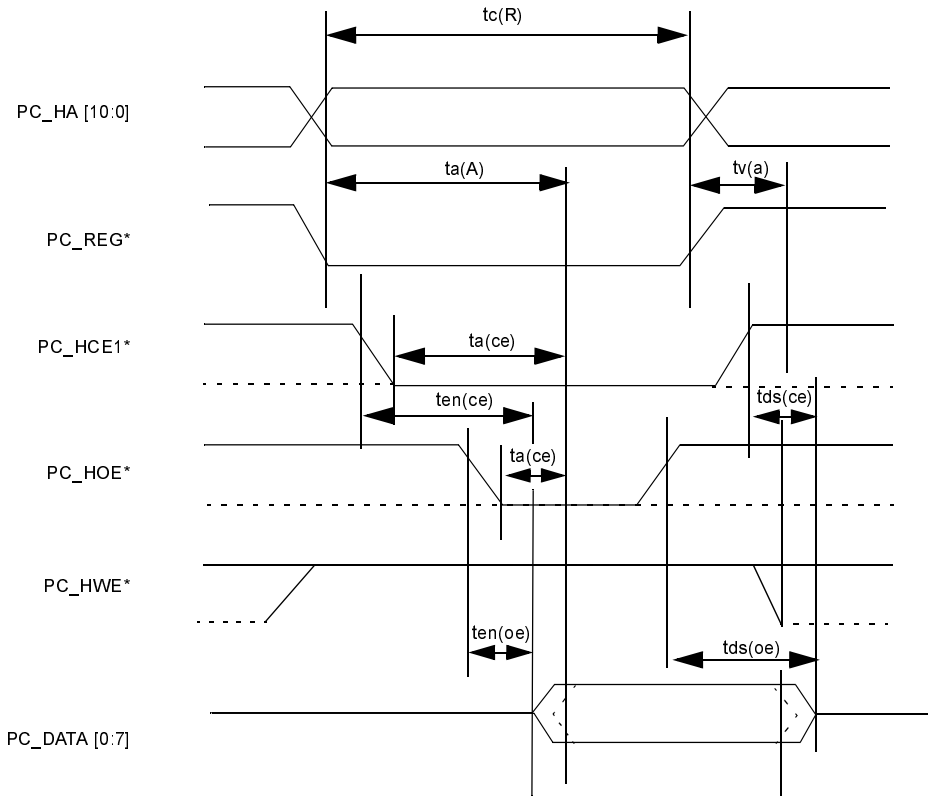

Table 10. I/O Read Timing Specification (Continued)

Item	Symbol	Min	Max	Units
REG hold following IORD	thREG(IORD)	0		nS
INPACK Delay to IORD	tdINPACK(IORD)	0	45	nS
INPACK Delay from IORD	tdINPACK(IORD)		45	nS
10IS16 Delay from Address	tdIOIS16(ADR)		35	nS
10IS16 Delay Rise From Address	tdIOIS16(ADR)		35	nS
Wait Delay from IORD	tdWAIT(IORD)		35	nS
Data Delay from Wait Rising	td W Ty		35	nS
Wait Width Time	tw WT		12	μS

Table 11. I/O Write Timing Specification

Item	Symbol	Min	Max	Units
Data Setup before IOWR	tsu(IOWR)	60		nS
Data Hold after IOWR	th(IOWR)	30		nS
IOWR Width Time	tw(IOWR)	165		nS
Address setup to IOWR	tsuA(IOWR)	70		nS
Address Hold after IOWR	thA(IOWR)	20		nS
CE setup before IOWR	tsuCE(IOWR)	5		nS
CE hold after IOWR	thCE(IOWR)	20		nS
REG Setup before IOWR	tsuREG(IOWR)	5		nS
REG hold after IOWR	thREG(IOWR)	0		nS
10IS16 Delay falling from Address	tdIOIS16(ADR)		35	nS
IOIS16 delay Rising from Address	tdIOIS16(ADR)		35	nS
Wait Delay Falling from IOWR	tdWAIT(IOWR)		35	nS
Wait Width Timing	twWAIT		12	μS



Note: PC_REG* is active Low for Attribute Memory reads only

Figure 7. PCMCIA Read Memory Timing, No Wait States

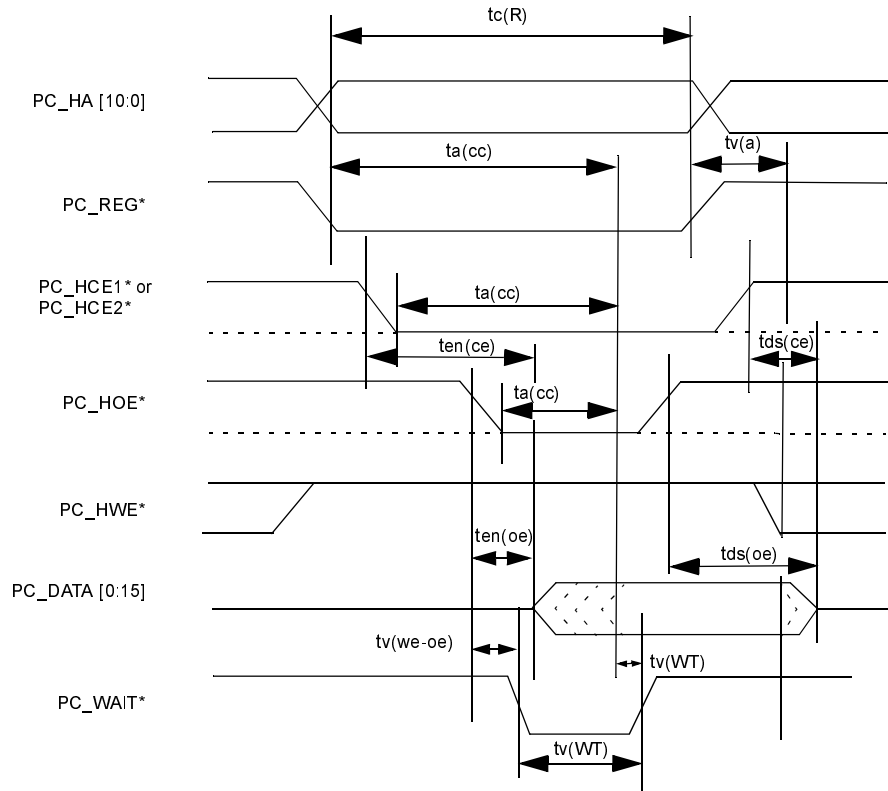

Note: PC_REG* is active Low for Attribute Memory reads only

Figure 8. PCMCIA Read Memory Timing, Wait State Enabled

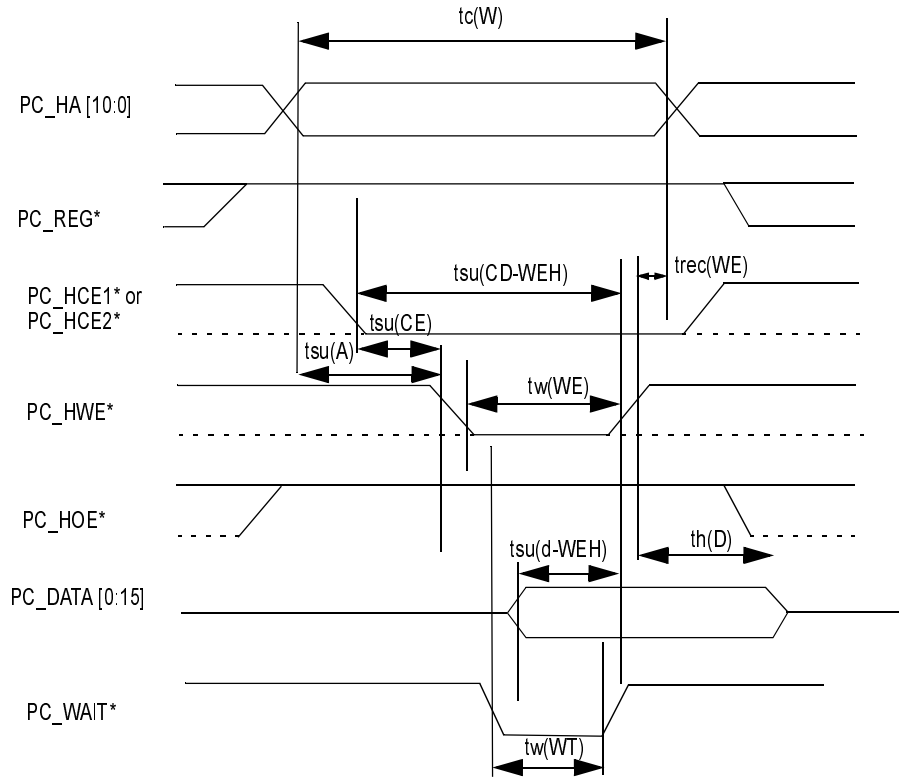

Figure 9. PCMCIA Memory Timing, Wait State Enabled

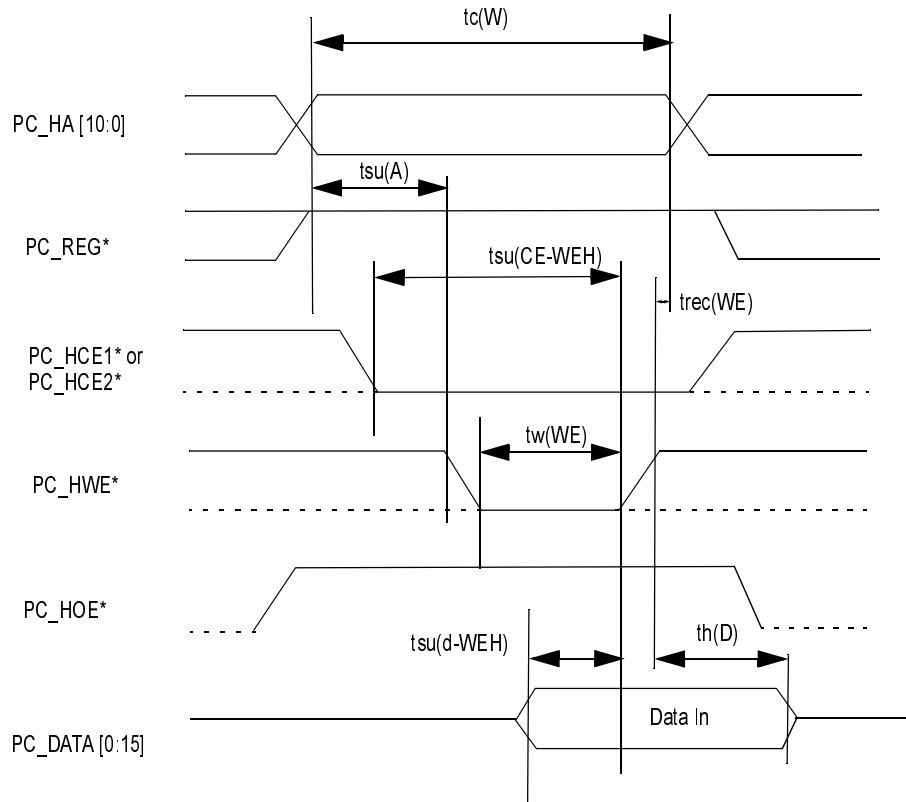

Figure 10. PCMCIA Memory Write Timing, No Wait States

Table 12. SKEW Timing between PCMCIA and ATA Bus

Item	Symbol	Min	Max
Address Skew	tskew(ADR)		25 nS
IO Fall Skew	tskew_Fall(IO)		25 nS
IO Rise Skew	tskew_Rise(IO)		25 nS
Mem Fall Skew	tskew_Fall(Mem)		25 nS
Mem Rise Skew	tskew_Rise(Mem)		25 nS

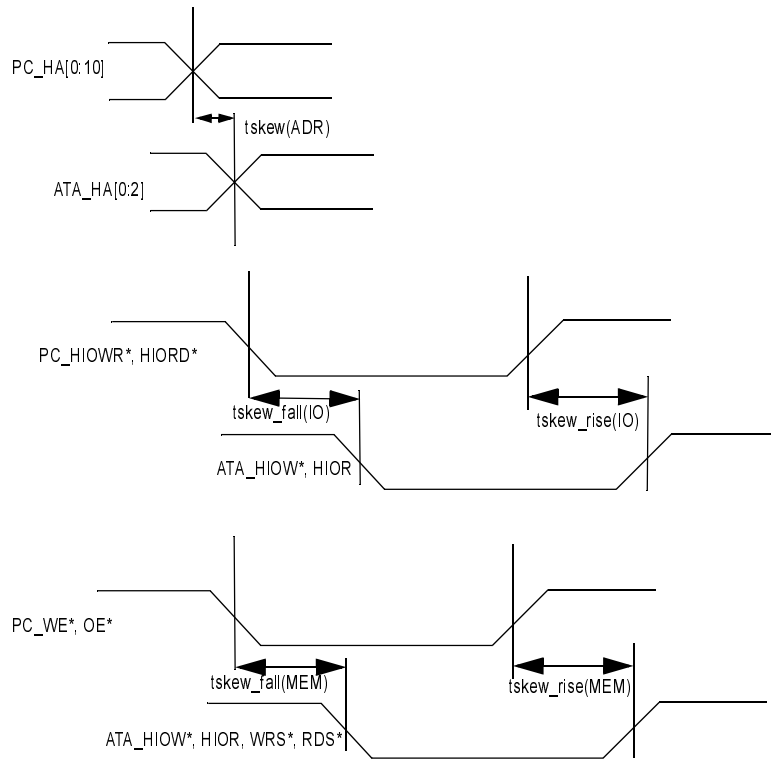

Figure 11. SKEW Timing between PCMCIA and ATA Bus

Table 13. Serial Interface Timing

Item	Symbol	Min	Max	Units
Master Clock In Period	tp(MCLK_IN)	50		nS
CS setup to CLK time	tsu(CS)	25		nS
CS hold after CLK	th(CS)	0		nS
Data Hold Time	th(D _{out})	10		nS
Data Setup Time	ts(D _{out})	25		nS
Data Hold Time	th(D _{in})	0		nS
Data Setup Time	tsu(D _{in})	25		nS
Clock Period, Write	tp(SK)	200		nS
Clock Period, Read	tp(SK READ)	200		nS
Clock Period,	tp(SK SLAVE)	200		nS

EEPROM Master Timing

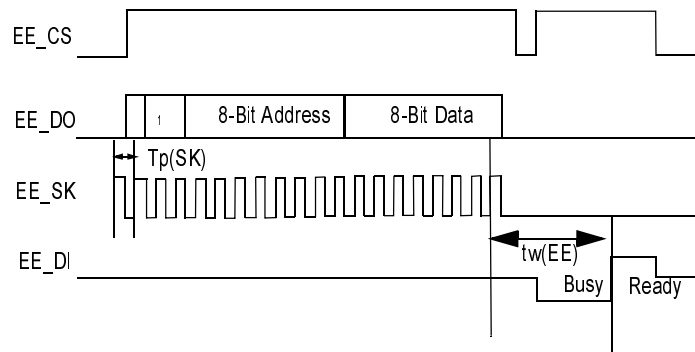

Figure 12. Write EEPROM Timing

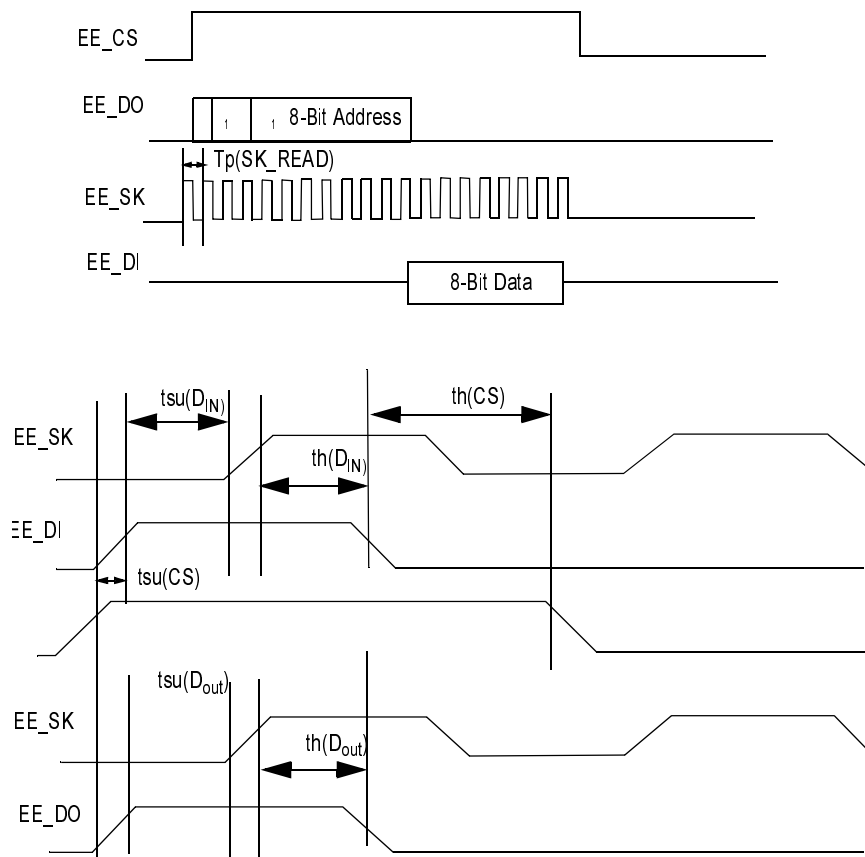

Figure 13. Read EEPROM Timing

Slave Interface Timing, Serial Bus

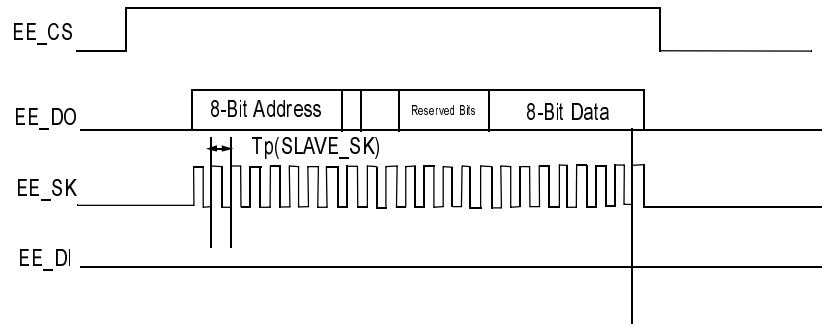

Figure 14. Write Slave Timing

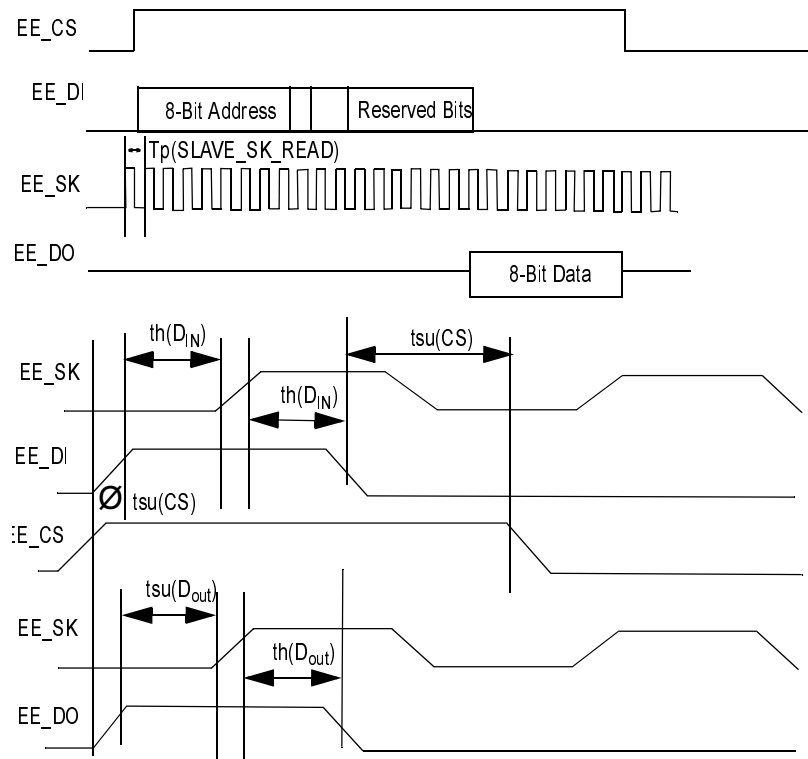

Figure 15. Read Slave Timing

PCMCIA I/O Timing

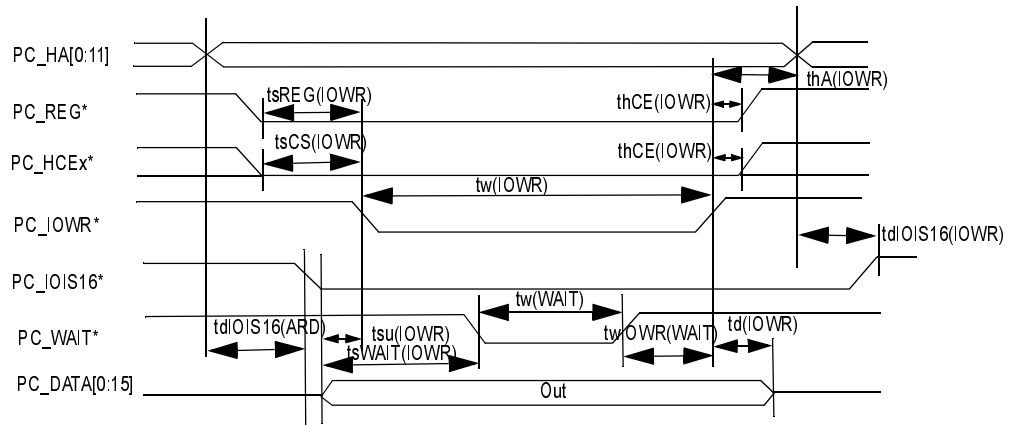

Figure 16. I/O Write Timing

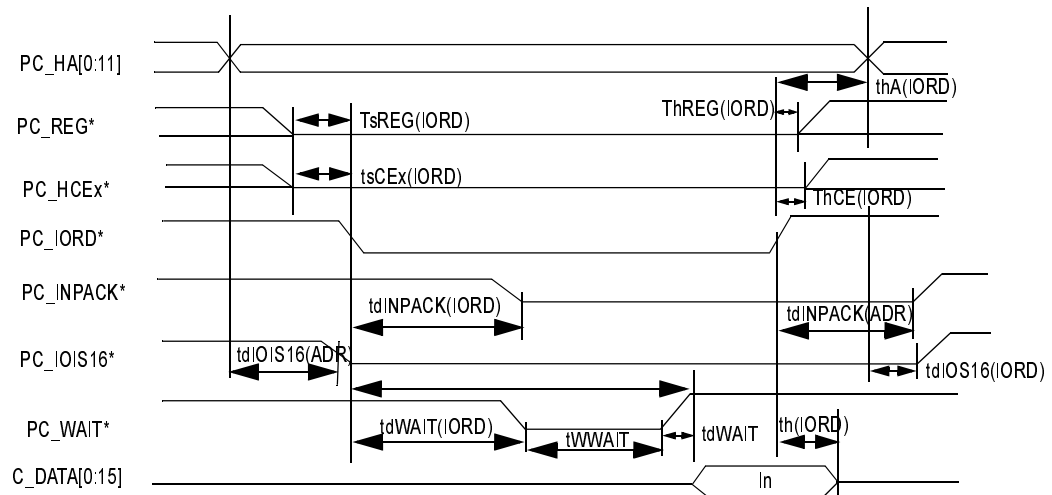

Figure 17. I/O Read Timing

Package Information

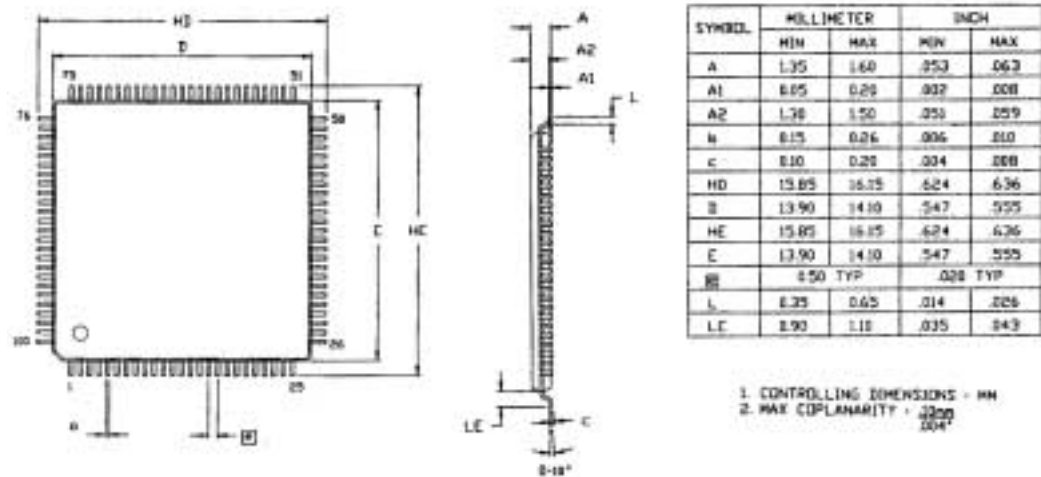

Figure 18. 100-Lead Plastic Very Small Quad Flatpack (VQFP)

Ordering Information

Z86017

- 20 MHz 100-pin VQFP
- Z8601720ASC

For fast results, contact your ZiLOG sales office for assistance in ordering the part desired.

Package

A = Very Small CFP

Temperature

S = 0 °C to +70 °C

Speed

20 = 20 MHz



Environmental

C = Plastic Standard

Example:

