

# SOUND SIGNAL PROCESSOR

查询YM3412B供应商

捷多邦, 专业PCB打样工厂, 24小时加急出货

Digital Compressor

## YM3412B COMP

### ■ OUTLINE

Wide dynamic range is one of the most significant features of digital audio signals. However, this feature can be a disadvantage of the total system, when digital audio is used with analog system having limited dynamic range such as car CD, portable CD or headphone CD, or when recording CD to a cassette tape.

There is also a problem when part of a low volume signal is lost during attenuation of digital output or during digital volume processing.

The latest yamaha digital sound processing technology has been used to create an LSI chip with a compressor function (which includes a volume processing option) that will automatically respond to the input level and compress the dynamic range of the digital audio signal.

### ■ FEATURES

- An input signal emulation compressor based on digital sound processing technology. Automatic emulation of low or high volume input signals, based on a unique input signal level detection circuit.
- Capable to cope with MSB first 2's complementary input signals with  $f_s$  at 32 KHz, 44.1 KHz, 48 KHz or double  $f_s$ .
- Capability in 2 modes:

<Mode 1> (Compressor)

Four different compression ratios can be employed, determined by the setting of the compression switching terminals (SEL0,SEL1).

Compression ratios vary when detected input level is between  $-54\text{dB}$  and  $-18\text{dB}$ . Below  $-54\text{dB}$ , the input and output values are equal, and beyond  $-18\text{dB}$ , attenuation is carried out. DCR (DCR is the dynamic compression ratio when the detected input level is between  $-54\text{dB}$  and  $-18\text{dB}$ .)

1. 1/1 Input and output levels are equal.
2. 3/4 When the detected input level is over  $-18\text{dB}$ , the reduced rate is fixed at  $-9\text{dB}$ .
3. 2/3 When the detected input level is over  $-18\text{dB}$ , the reduced rate is fixed at  $-12\text{dB}$ .
4. 1/2 When the detected input level is over  $-18\text{dB}$ , the reduced rate is fixed at  $-18\text{dB}$ .

<Mode 2> (Digital Attenuator with compressing)

When an external microprocessor is used to input volume data (8bit, attenuation at  $0.375\text{dB}$ ), attenuation of sound of volume is carried out while still maintaining the compressor function. (During initial clear, muting condition is set with the volume value " $\infty$ ".)

- CMOS, 18 pin, plastic DIP, +5V power supply

### ■ ELECTRICAL CHARACTERISTICS

#### (1) Absolute Maximum Ratings

Item	Symbol	Min	Max	Unit
Supply voltage	$V_{DD}$	$-3.0$	$+7.0$	V
Input voltage	$V_I$	$-0.3$	$V_{DD}+0.5$	V
Ambient operating temperature	$T_{OP}$	0	$+70$	$^{\circ}\text{C}$
Storage temperature	$T_{STG}$	$-50$	$+125$	$^{\circ}\text{C}$

### (2) Recommended Operating Conditions

Item	Sybol	Min	Typ	Max	Unit
Supply voltage	V <sub>DD</sub>	4.75	5.00	5.25	V
Ambient operating temperature	T <sub>Op</sub>	0	25	+70	°C

### (3) DC Characteristics

Item	Symbol	Condition	Min	Typ	Max	Unit
Supply voltage	I <sub>DD</sub>	V <sub>DD</sub> = 5V				mA
High output voltage	V <sub>OH</sub>	I <sub>OH</sub> = 20μA	4.0			V
Low output voltage	V <sub>OL</sub>	I <sub>IOL</sub> = 1mA			0.4	V
High input voltage 1	V <sub>IH1</sub>		3.5			V
Low input voltage 1	V <sub>IL1</sub>				1.5	V
High input voltage 2	V <sub>IH2</sub>		2.0			V
Low input voltage 2	V <sub>IL2</sub>				0.8	V
Input current leakage	I <sub>IL</sub>		-10		10	mA

## OUTLINE DIMENSIONS

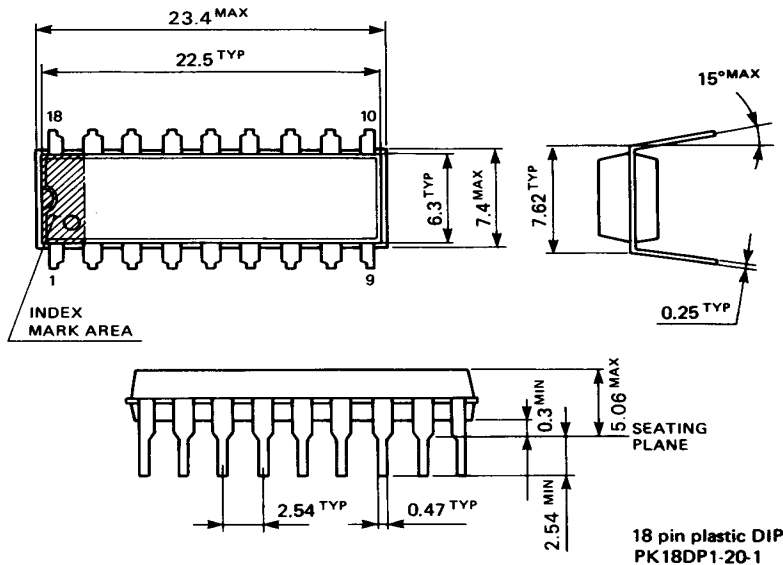

## BLOCK DIAGRAM

