

### Description

The YB1200R is a series of ultra-low-noise, low dropout (LDO) linear regulators with 2.0% output voltage accuracy. The YB1200R regulators achieve a low 180mV dropout at 150mA load current of 3.3V output and are available in voltages ranging from 1.2V to 3.6V with 0.1 V per step (custom voltage is considerable at request).

The YB1200R regulators are optimized to work with low-ESR and low cost ceramic capacitors, reducing the amount of board space critical in portable devices. The YB1200R requires only 0.47  $\mu$ F output capacitor for stability with any load and consumes less than 1 $\mu$ A in shutdown mode. YB1200R also deploys an auto-discharge circuit which can de-energize the output capacitor to prevent the system from abnormal operation during shutdown.

Built-in thermal shutdown and short-circuit protect offer secure protection against fault operation. The YB1200R regulators are available in SC-70 / SC-82 packages.

### Features

- High Accuracy Output Voltage :  $\pm 2\%$
- Wide Output Voltage Range : 1.2~3.6V
- Ultra-Low-Noise Low-Drop-Out
- Typical Output Current : 150 mA
- Low Quiescent Current:  $\sim 60\mu$ A
- 180mV Dropout at 150mA 3.3V Output
- Stable with 0.47 $\mu$ F Ceramic Capacitor
- Only Need Input and Output Capacitors
- Thermal Protection Shutdown
- Output Short-Circuit Current Limit
- Built-In Internal Soft-Start
- Built-In Auto-Discharge Function
- Green Package (RoHS) Available

### Applications

- PDA, Notebook, PC Computers
- DSC, Handset Camera Modules
- PCMCIA Cards, PC Cameras
- USB Based Portable Devices
- GSM/GPRS/3G RF Transceiver
- Wireless LANs
- Bluetooth Portable Radios
- Battery-Powered Devices

### Typical Application Circuitry

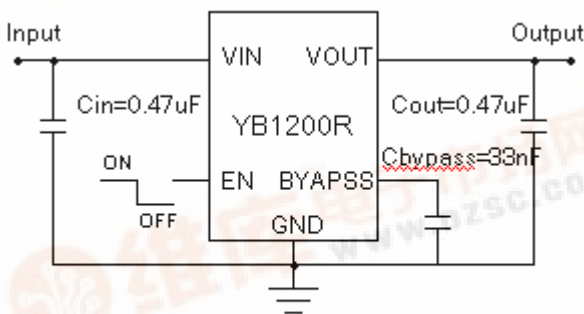

Figure 1-1 : SC-70 application circuit

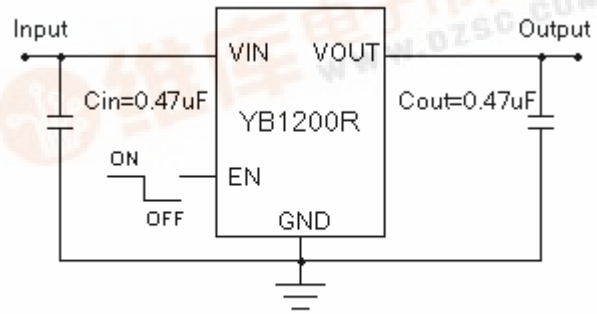

Figure 1-2 : SC-82 application circuit

### Pin Configuration

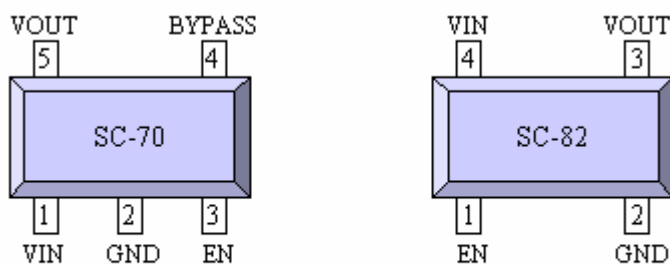

Figure 2 : pin configuration

### Pin Description

Table 1

Pin Name	Pin Function
VIN	Unregulated Input Supply. Bypass with a capacitor to GND.
GND	Ground pin.
EN	Pull high to enable the regulator.
BYPASS	Connect a 33nF capacitor to GND for low noise operation.
VOUT	Regulated Output Voltage. Bypass with a capacitor to GND.

### Ordering Information

YB 1 2 0 0           R        

Output Voltage  
 1 2 0 : 1.2 V  
 1 3 0 : 1.3 V  
 :  
 3 6 0 : 3.6 V

Package Type  
 SC70 : SC-70  
 SC82 : SC-82

- Order example :  
 YB1200SC82R250 for YB1200R of 2.5V output and SC-82 package
- Shipping Quantity :  
 SC-70 : 3000 units tape & reel  
 SC-82 : 3000 units tape & reel
- Only green package

### Marking Information

X  

Code	A	B	C	D	E	F	G	H	I	J	K	L	M
Voltage	1.2	1.3	1.4	1.5	1.6	1.7	1.8	1.9	2.0	2.1	2.2	2.3	2.4
Code	N	O	P	Q	R	S	T	U	V	W	X	Y	
Voltage	2.5	2.6	2.7	2.8	2.9	3.0	3.1	3.2	3.3	3.4	3.5	3.6	

### Absolute Maximum Ratings

Supply Voltage ..... -0.3V to 7.0V  
 Output Voltage ..... -0.3V to (V<sub>IN</sub>+0.3V)  
 Output Short-Circuit Duration ..... Infinite  
 Junction Temperature Range ..... +150°C  
 Storage Temperature Range ..... -65°C to +150°C  
 Lead Temperature ..... +250°C  
 Thermal Resistance (SC-70/82, θ<sub>JA</sub>) ..... 330°C/W  
 Internal Power Dissipation (SC-70/82, P<sub>D</sub>) ..... 0.3W

### Recommended Operating Conditions

Input Supply Voltage ..... 2V to 6.0V  
 Operating Temperature ..... -40°C to +85°C  
 ESD Susceptibility (HBM) ..... 2KV  
 ESD Susceptibility (MM) ..... 200V

### Electrical Characteristics

Table 2

$T_A = 25^\circ\text{C}$ ,  $V_{IN} = (V_{OUT} + 1\text{V})$ ,  $C_{IN} = C_{OUT} = 0.47\mu\text{F}$ ,  $V_{EN} = V_{IN}$ , unless otherwise noted

Function Parameter	Conditions	Min	Typ	Max	Units
Input Voltage Range		2.0		6.0	V
Output Voltage	Predefined	1.2		3.6	V
Output Voltage Accuracy	$I_{OUT} = 10\text{mA}$ , $V_{OUT} \geq 1.3\text{V}$	-2.0		+2.0	%
	$I_{OUT} = 10\text{mA}$ , $V_{OUT} = 1.2\text{V}$	0		+4.0	%
Output Current Limit	Short-circuit output		45		mA
Dropout Voltage (Note 1)	$V_{out} = 3.6\text{V}$ , $I_{out} = 150\text{mA}$		150		mV
	$V_{out} = 3.0\text{V}$ , $I_{out} = 150\text{mA}$		180		
	$V_{out} = 2.5\text{V}$ , $I_{out} = 150\text{mA}$		250		
	$V_{out} = 1.5\text{V}$ , $I_{out} = 150\text{mA}$		380		
	$V_{out} = 1.2\text{V}$ , $I_{out} = 150\text{mA}$		510		
Ground Current	$I_{ground} = I_{in} - I_{out}$		60		$\mu\text{A}$
Line Regulation	$V_{in} = (V_{out} + 1\text{V})$ to 6V, $I_{out} = 10\text{mA}$		0.30	0.40	%/V
Load Regulation	$I_{out} = 1\text{mA}$ to 150 mA		0.6	1.2	%
Shutdown Supply Current	$EN = 0.4\text{V}$		0.01		$\mu\text{A}$
Ripple Rejection (PSRR)	$f = 1\text{KHz}$ , $I_{out} = 1\text{mA}$		60		dB
	$f = 10\text{KHz}$ , $I_{out} = 1\text{mA}$		78		
	$f = 100\text{KHz}$ , $I_{out} = 1\text{mA}$		69		
Start Up Delay (Note 2)	$R_{load} = 100\text{ohm}$ , $C_{bypass} = 0\text{nF}$		20	50	$\mu\text{S}$
	$R_{load} = 100\text{ohm}$ , $C_{bypass} = 33\text{nF}$		2	3.5	mS
Shutdown Delay (Note 3)	$R_{load} = 10\text{K ohm}$ , $V_{OUT} = 1.5\text{V}$		1		mS
	$R_{load} = 10\text{K ohm}$ , $V_{OUT} = 1.2\text{V}$		1		mS
EN Logic Low Level	$V_{in} = 2.0\text{V}$ to 6.0V			0.4	V
EN Logic High Level	$V_{in} = 2.0\text{V}$ to 6.0 V	1.2		$V_{in}$	V
EN Input Bias Current	$V_{in} = EN = V_{out} + 1\text{V}$		0.01		$\mu\text{A}$
Thermal Shutdown	Shutdown Temperature		160		$^\circ\text{C}$
Thermal Hysteresis			20		$^\circ\text{C}$

**Note 1 :** The drop out voltage varies depending on output voltage selection. Dropout is defined as  $V_{IN} - V_{OUT}$  when  $V_{OUT}$  is 100mV below  $V_{OUT}$  where  $V_{in} = V_{out} + 1\text{V}$  for nominal  $V_{OUT}$ .

**Note 2:** Time needed for  $V_{OUT}$  to reach 90% of final value.

**Note 3:** Time needed for  $V_{OUT}$  to discharge below 0.5V.

### Typical Characteristics

At  $T_A=25^\circ\text{C}$ ,  $V_{IN}=(V_{OUT}+1\text{V})$ ,  $C_{IN}=C_{OUT}=0.47\mu\text{F}$ ,  $V_{EN}=V_{IN}$ , unless otherwise noted.

**Dropout Voltage vs Output Load**

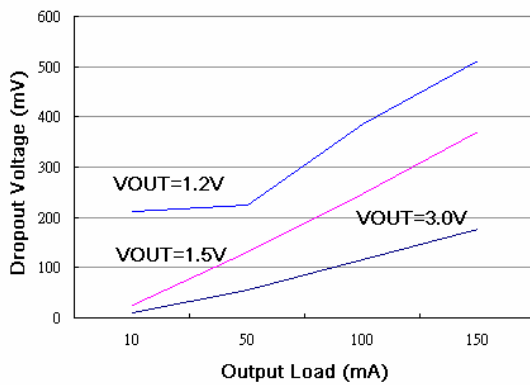

**Ground Current vs Input Voltage**

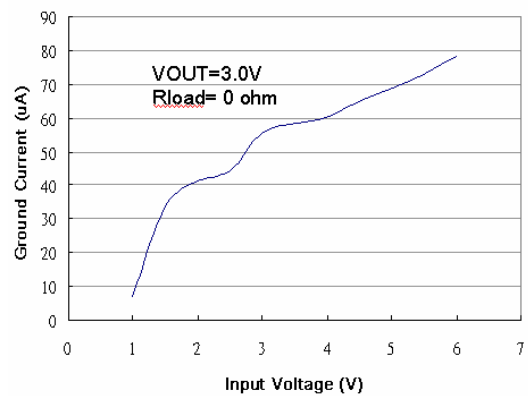

**Dropout Voltage vs Temperature**

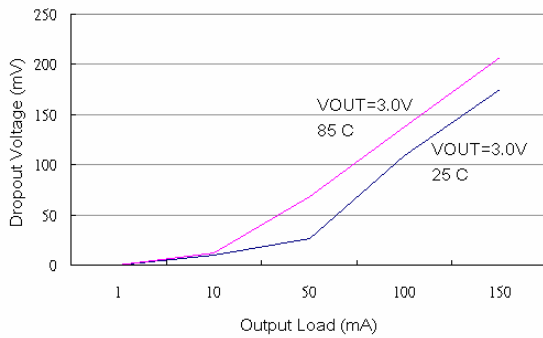

**Dropout Voltage vs Temperature**

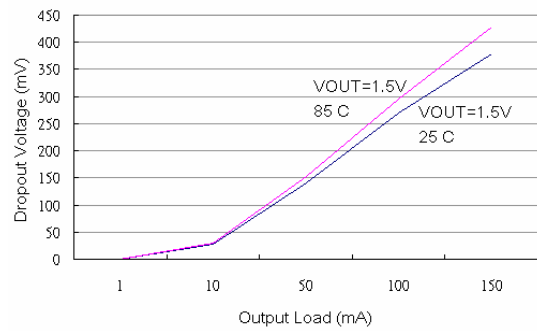

**Output Voltage vs Temperature**

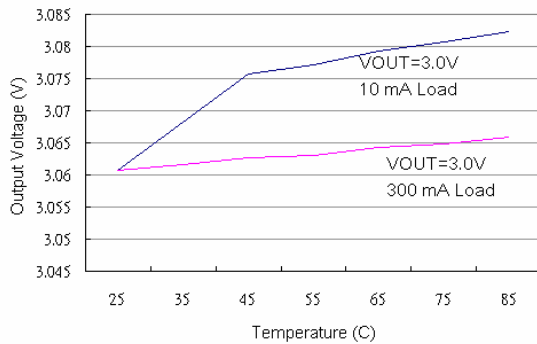

**Output Voltage vs Temperature**

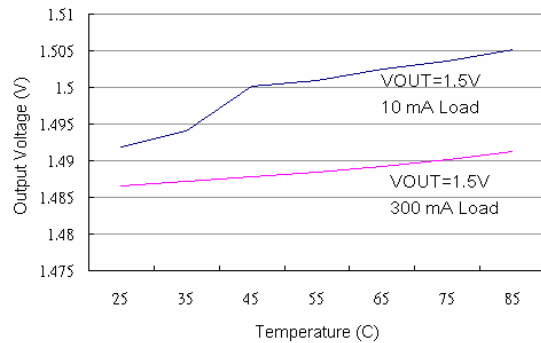

## 150mA High PSRR with Auto-Discharge LDO Regulator

Line Transient Response

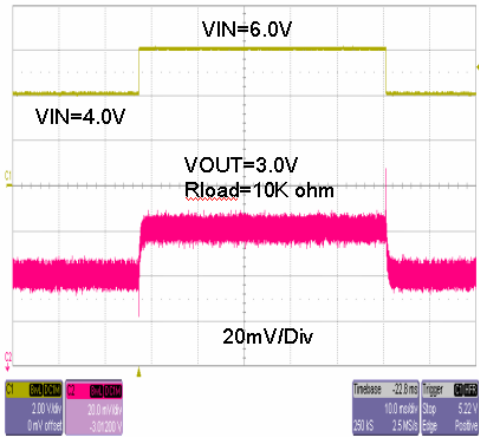

Load Transient Response

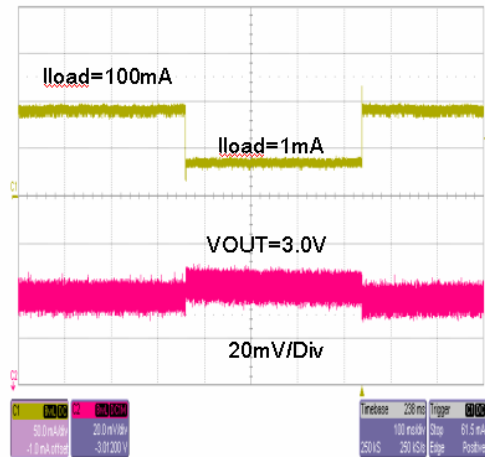

Start Up Delay (C<sub>bypass</sub>=0nF)

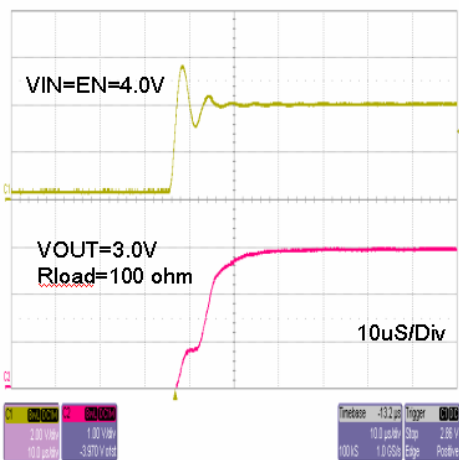

Start Up Delay (C<sub>bypass</sub>=33nF)

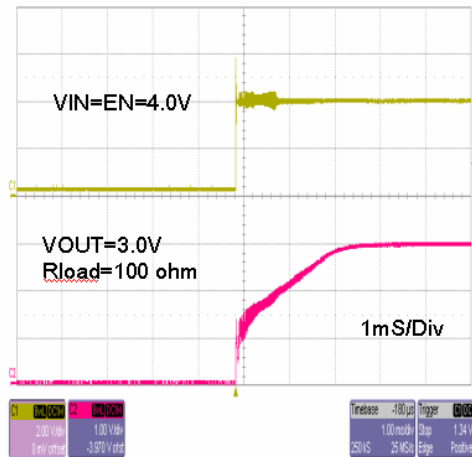

Shutdown Delay (VOUT=1.2V)

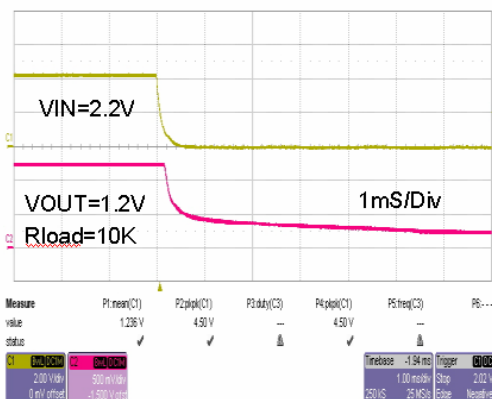

Shutdown Delay (VOUT=1.5V)

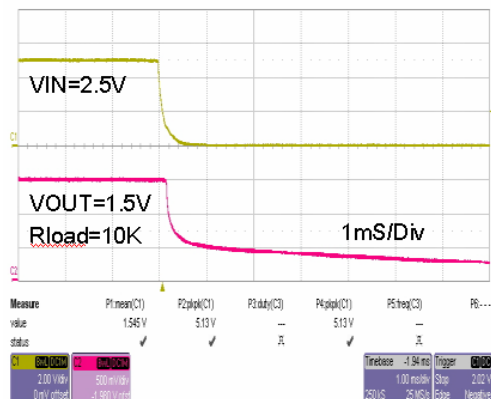

PSRR vs Frequency (1 mA load)

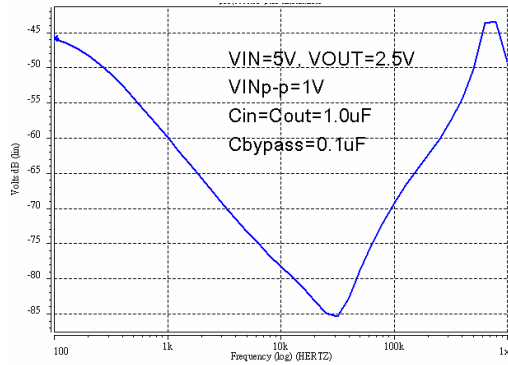

PSRR vs Frequency (100 mA load)

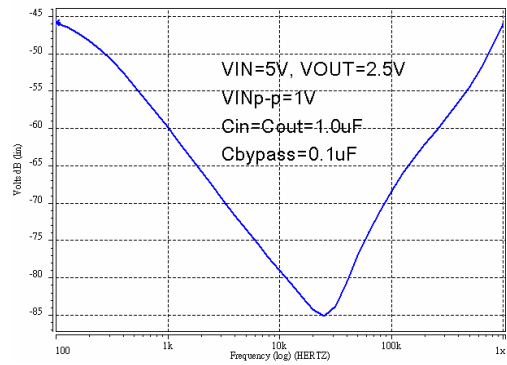

PSRR vs Frequency (10 mA load)

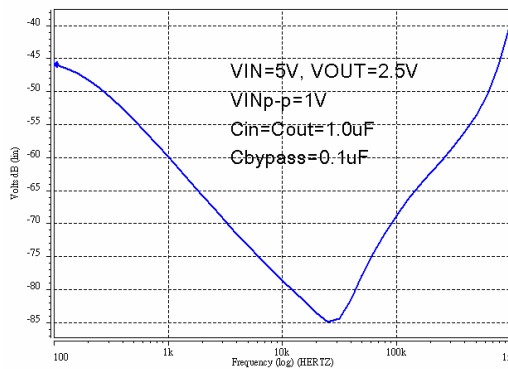

### Functional Block Diagram

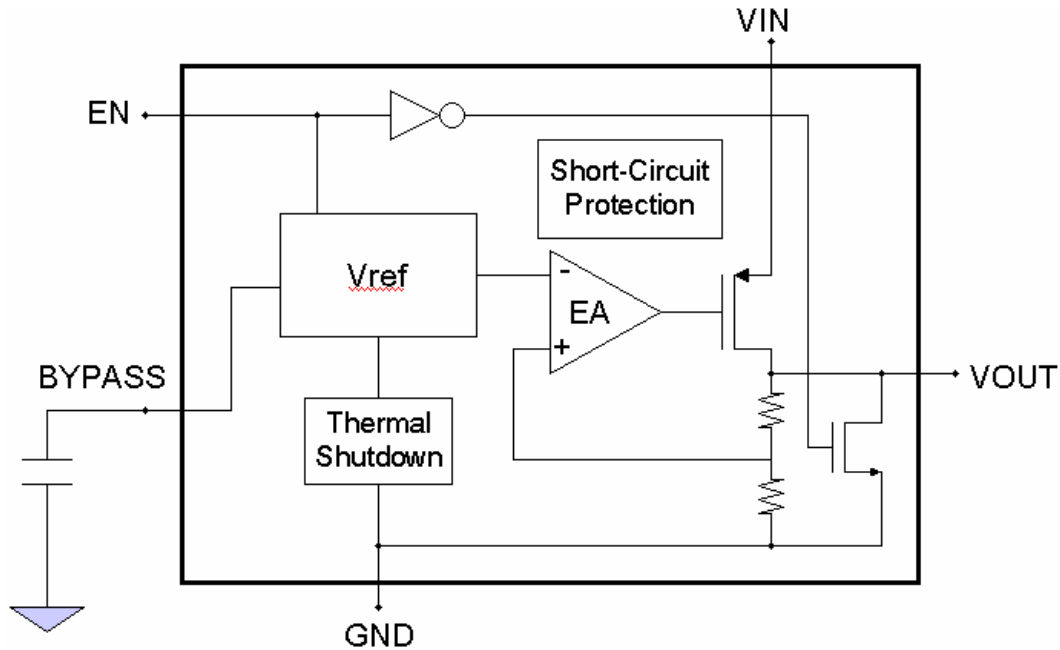

Figure 3 : Function Diagram

### Functional Description

The YB1200R is an ultra-low-noise, low-quiescent current, low-dropout linear regulator. It is supplied in a extremely small SC-70 / SC82 package for different applications. YB1200R can supply loads up to 150mA (typical operation, not maximum) and output voltages are preset and ranging from 1.2V to 3.6V.

As shown in the *Functional Block Diagram*, the YB1200R consists of a reference and noise bypass circuit, error amplifier, output drive transistor, internal feedback voltage divider, thermal sensor, and short circuit current limiter.

The internal reference is connected to the error amplifier's inverting input. The error amplifier compares this reference with the feedback voltage and amplifies the difference. If the feedback voltage is lower

than the reference voltage, the gate of the pass-transistor is pulled low. This allows more current to pass to the output and increases the output voltage. If the feedback voltage is too high, the gate of the pass transistor is pulled high, allowing less current to pass to the output.

#### Stability

The YB1200R is a high performance LDO emphasizing stability with low output capacitance. It is able to maintain stability with an output capacitor as low as 0.47 uF. The output capacitor can also be increased to optimize performance. The YB1200R will remain stable and in regulation with no load, unlike many other voltage regulators.

#### Internal P-Channel Pass Transistor

The YB1200R features a low impedance



P-channel MOSFET pass transistor. This provides several advantages over similar designs using a PNP pass transistor, including low operating power and longer battery life. The YB1200R consumes only 60 $\mu$ A of quiescent current under most conditions.

### **Output Short-Circuit Current Limit**

The YB1200R includes a current limiter, which monitors and controls the pass transistor's gate voltage, limiting the output current to about 200mA, for example, in a short-circuit output situation.

### **Shutdown**

The YB1200R also features a low-power active shutdown mode. It has a switch that turns off the device when disabled. This allows the output capacitor and load to discharge and de-energize the load. In the shutdown mode, the internal functional blocks, such as voltage reference and the error amplifier, are turned off completely, and the quiescent current is less than 1 $\mu$ A.

### **Thermal Protection Shutdown**

The thermal protection shutdown function protects the device from operating in over temperature condition. When the junction temperature exceeds +160 $^{\circ}$ C, the thermal sensor signals the shutdown logic, turning off the pass transistor and allowing the IC to cool down. The thermal sensor turns the pass transistor on again after the IC's junction temperature drops to +140 $^{\circ}$ C.

### **Auto-Discharge Circuitry**

The YB1200R deploys a NMOS connecting between VOUT and ground. When EN pin is pulled low, the NMOS is activated by an inverted signal from EN. The charge kept on output capacitor is discharged quickly through the NMOS. It prevents the system

from abnormal operation at the beginning of shutdown mode.

### **Soft-Start Circuitry**

The YB1200R includes a soft-start circuitry to limit inrush current at turn-on. During power up, the output capacitor and output load are charged with a reduced output current. Shortly after the initial power up, the soft-start feature is terminated and normal operation is resumed.

## **Application Information**

### **Enable/Shutdown**

The YB1200R comes with an active-high enable pin that allows the regulator to be enabled. Forcing the enable pin low disables the regulator and puts it into the shutdown mode. This pin cannot be left floating as it may cause an undetermined state.

### **Input/Output Capacitor**

It is recommended to use a 1.0 $\mu$ F capacitor on the YB1200R input and a 1.0 $\mu$ F capacitor on the output. For high regulation performance, larger input capacitor values and lower ESRs provide better noise rejection and line-transient response. The output noise, load-transient response, stability, and power-supply rejection can be improved by using large output capacitors. Low ESR ceramic capacitors provide optimal performance and save space.

### SC-70 Package Information

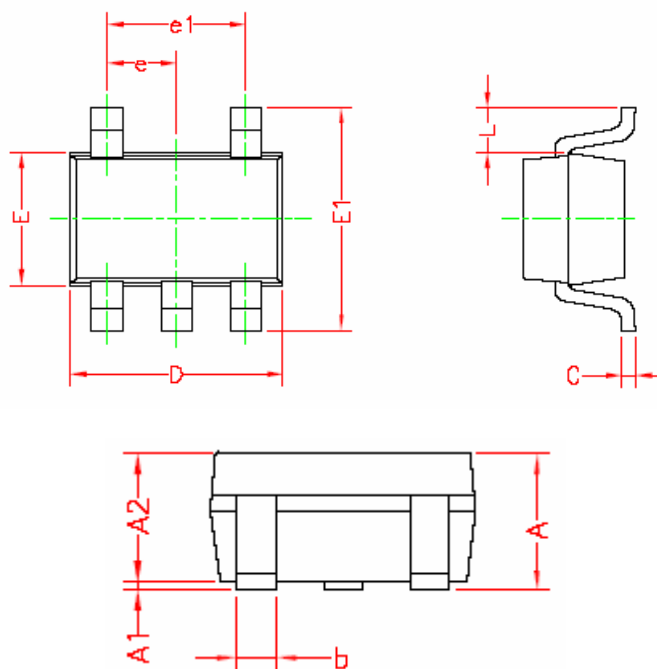

Symbol	Millimeters		Inches	
	MIN.	MAX.	MIN.	MAX.
A	0.90	1.10	.036	0.44
A1	0.025	0.10	.001	.004
A2	0.875	1.00	.035	.040
b	0.20	0.40	.008	.016
C	0.10	0.15	.004	.006
D	1.90	2.10	.076	.084
E	1.15	1.35	.046	.054
E1	2.00	2.20	.080	.088
e	0.65 BSC.		.026 BSC.	
e1	1.30 BSC.		.052 BSC.	
L	0.425 REF.		.017 REF.	

Note:

1. All dimensions are in millimeters, and the dimensions in inches are for reference only.
2. 1mm=40mils=0.04inches

### SC-82 Package Information

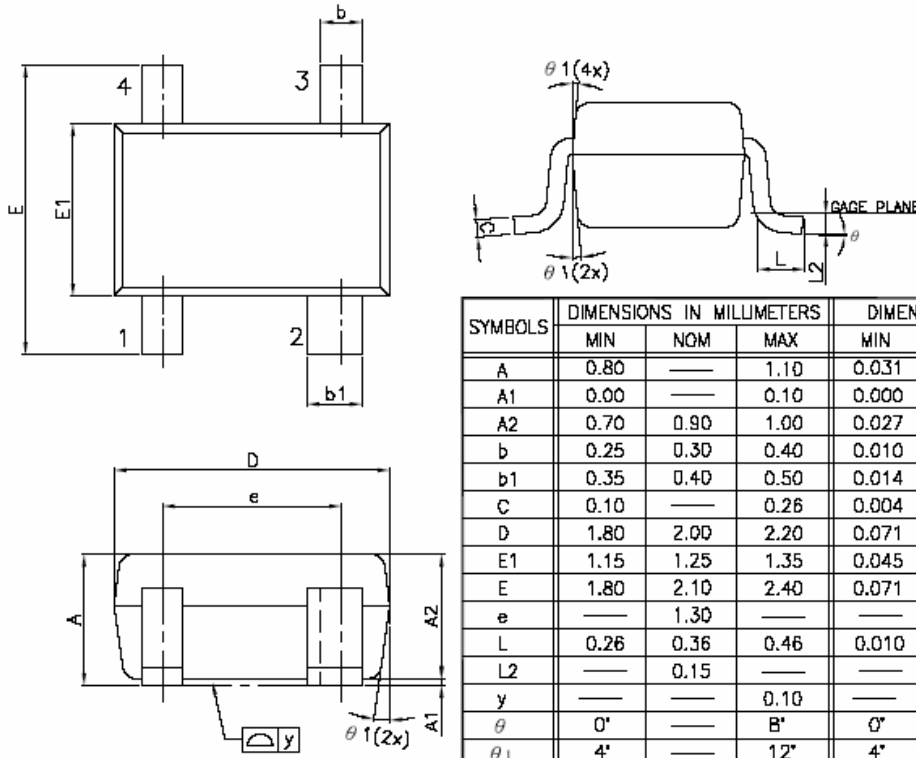

SYMBOLS	DIMENSIONS IN MILLIMETERS			DIMENSIONS IN INCHES		
	MIN	NOM	MAX	MIN	NOM	MAX
A	0.80	—	1.10	0.031	—	0.043
A1	0.00	—	0.10	0.000	—	0.004
A2	0.70	0.90	1.00	0.027	0.035	0.039
b	0.25	0.30	0.40	0.010	0.012	0.016
b1	0.35	0.40	0.50	0.014	0.016	0.020
C	0.10	—	0.26	0.004	—	0.010
D	1.80	2.00	2.20	0.071	0.079	0.087
E1	1.15	1.25	1.35	0.045	0.049	0.053
E	1.80	2.10	2.40	0.071	0.083	0.094
e	—	1.30	—	—	0.051	—
L	0.26	0.36	0.46	0.010	0.014	0.018
L2	—	0.15	—	—	0.006	—
y	—	—	0.10	—	—	0.004
$\theta$	0°	—	8°	0°	—	8°
$\theta_1$	4°	—	12°	4°	—	12°

**NOTE:**

1. CONTROLUNG DIMENSION: mm
2. LEAD FRAME MATERIAL:EFTEC-64T 1/2H OR H.
3. DIMENSION D DOES NOT INCLUDE MOLD FLASH, PROTRUSIONS OR GATE BURRS, MOLD FLASH/PROTRUSIONS OR GATE BURRS SHALL NOT EXCEED 0.15 mm PER SIDE,
4. DIMENSION E1 DOES NOT INCLUDE INTERLEAD FLASH OR PROTRUSION. INTERLEAD FLASH OR PROTRUSION SHALL NOT EXCEED 0.15mm PER SIDE.