



Advance Information
Terminal Voltage 0V to +10V

X9311

E²POT™ Digitally Controlled Potentiometer

FEATURES

- **Compatible with X9MME and X9CMM E**
- **Low Power CMOS**
 - Active Current, 3 mA Max
 - Standby Current, 500 μA Max
- **99 Resistive Elements**
 - Temperature Compensated
 - ± 20% End to End Resistance Range
 - 0 to 10V Range
- **100 Wiper Tap Points**
 - Wiper Positioned via Three Wire Interface
 - Similar to TTL Up/Down Counter
 - Wiper Position Stored in Nonvolatile Memory and Recalled on Power-Up
- **100 Year Wiper Position Data Retention**
- **X9311Z = 1K Ohms**
- **X9311W = 10K Ohms**
- **X9311U = 50K Ohms**
- **X9311T = 100K Ohms**

DESCRIPTION

The Xicor X9311 is a solid state nonvolatile potentiometer and is ideal for digitally controlled resistance trimming.

The X9311 is a resistor array composed of 99 resistive elements. Between each element and at either end are tap points accessible to the wiper element. The position of the wiper element is controlled by the CS, U/D, and INC inputs. The position of the wiper can be stored in nonvolatile memory and then be recalled upon a subsequent power-on operation.

The resolution of the X9311 is equal to the maximum resistance value divided by 99. As an example, for the X9311U (50 KΩ) each tap point represents 505Ω.

All Xicor nonvolatile memories are designed and tested for applications requiring extended endurance and data retention.

4

FUNCTIONAL DIAGRAM

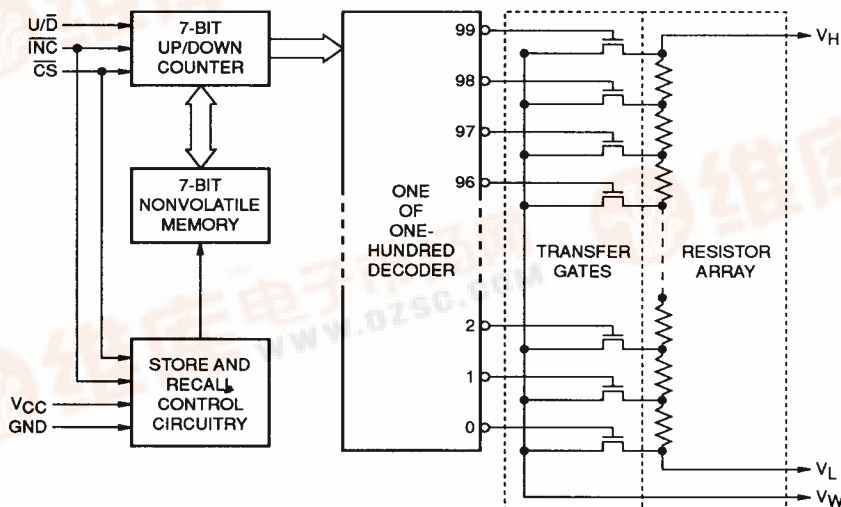

3862 FHD F01

X9311

PIN DESCRIPTIONS

V_H and V_L

The high (V_H) and low (V_L) terminals of the X9311 are equivalent to the fixed terminals of a mechanical potentiometer. The minimum and maximum voltage that may be applied to the terminals is determined by the voltage on V_{CC} . The minimum voltage is 0 and the maximum is +10. It should be noted that the terminology of V_L and V_H references the relative position of the terminal in relation to wiper movement direction selected by the U/\bar{D} input and not the voltage potential on the terminal.

V_W

V_W is the wiper terminal, equivalent to the movable terminal of a mechanical potentiometer. The position of the wiper within the array is determined by the control inputs. The wiper terminal series resistance is typically less than 40Ω.

Up/Down (U/\bar{D})

The U/\bar{D} input controls the direction of the wiper movement and whether the counter is incremented or decremented.

Increment (\bar{INC})

The \bar{INC} input is negative-edge triggered. Toggling \bar{INC} will move the wiper and either increment or decrement the counter in the direction indicated by the logic level on the U/\bar{D} input.

Chip Select (\bar{CS})

The device is selected when the \bar{CS} input is low. The current counter value is stored in nonvolatile memory when \bar{CS} is returned HIGH while the \bar{INC} input is also high. After the store operation is complete the X9311 will be placed in the low power standby mode until the device is selected once again.

PIN CONFIGURATION

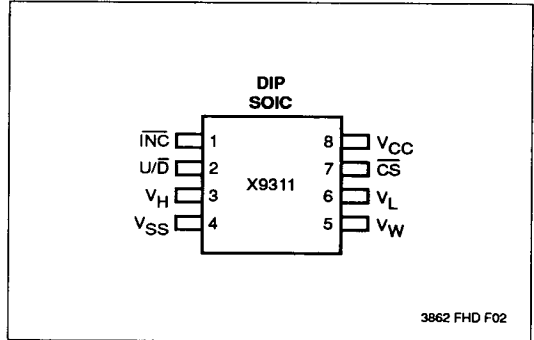

PIN NAMES

Symbol	Description
V_H	High Terminal
V_W	Wiper Terminal
V_L	Low Terminal
V_{SS}	Ground
V_{CC}	Supply Voltage
U/\bar{D}	Up/Down Input
\bar{INC}	Increment Input
\bar{CS}	Chip Select Input

3862 PGM T01

X9311

DEVICE OPERATION

There are three basic sections of the X9311: the input control, counter and decode section; the nonvolatile memory; and the resistor array. The input control section operates just like an up/down counter. The output of this counter is decoded to turn on a single electronic switch connecting a point on the resistor array to the wiper output. Under the proper conditions the contents of the counter can be stored in nonvolatile memory and retained for future use. The resistor array is comprised of 99 individual resistors connected in series. At either end of the array and between each resistor is an electronic switch that transfers the potential at that point to the wiper.

The \overline{INC} , U/\overline{D} and \overline{CS} inputs control the movement of the wiper along the resistor array. With \overline{CS} set low the X9311 is selected and enabled to respond to the U/\overline{D} and \overline{INC} inputs. High to low transitions on \overline{INC} will increment or decrement (depending on the state of the U/\overline{D} input) a seven bit counter. The output of this counter is decoded to select one of one-hundred wiper positions along the resistive array.

The wiper, when at either fixed terminal, acts like its mechanical equivalent and does not move beyond the last position. That is, the counter does not wrap around when clocked to either extreme.

The value of the counter is stored in nonvolatile memory whenever \overline{CS} transitions high while the \overline{INC} input is also high.

When the X9311 is powered down, the last counter position stored will be maintained in the nonvolatile memory. When power is restored, the contents of the memory are recalled and the counter is reset to the value last stored.

OPERATION NOTES

The system may select the X9311, move the wiper and deselect the device without having to store the latest wiper position in nonvolatile memory. The wiper movement is performed as described above; once the new position is reached, the system would keep \overline{INC} low while taking \overline{CS} high. The new wiper position would be maintained until changed by the system or until a power-off/on cycle recalled the previously stored data.

This would allow the system to always power-on to a preset value stored in nonvolatile memory; then during system operation minor adjustments could be made. The adjustments might be based on user preference, system parameter changes due to temperature drift etc.

The state of U/\overline{D} may be changed while \overline{CS} remains low. This allows the host system to enable the X9311 and then move the wiper up and down until the proper trim is attained.

T_{IW}/R_{TOTAL}

The electronic switches on the X9311 operate in a "make before break" mode when the wiper changes tap positions. If the wiper is moved several positions multiple taps are connected to the wiper for T_{IW} (\overline{INC} to V_W change). The R_{TOTAL} value for the device can temporarily be reduced by a significant amount if the wiper is moved several positions.

R_{TOTAL} with V_{CC} Removed

The end to end resistance of the array will fluctuate once V_{CC} is removed.

X9311

ABSOLUTE MAXIMUM RATINGS*

Temperature Under Bias	-65°C to +135°C
Storage Temperature	-65°C to +150°C
Voltage on \overline{CS} , \overline{INC} , U/\overline{D} and V_{CC} Referenced to Ground	-1.0V to +7.0V
Voltage on V_H and V_L Referenced to Ground	-1.0V to +13.0V
$\Delta V = (V_H \text{ and } V_L)$ X9311Z	4 V
X9311W, X9311U and X9311T	10 V
Lead Temperature (Soldering 10 Seconds)	+300°C
Wiper Current	± 1 mA

ANALOG CHARACTERISTICS

Electrical Characteristics

End-to-End Resistance Tolerance	$\pm 20\%$
Power Rating at 25°C X9311Z	16 mW
X9311W, X9311U and X9311T	10 mW
Wiper Current	± 1 mA Max.
Typical Wiper Resistance	40 Ω at 1 mA
Typical Noise	< -120 dB/ $\sqrt{\text{Hz}}$ Ref: 1 V

Resolution

Resistance	1%
------------------	----

Linearity

Absolute Linearity ⁽¹⁾	± 1.0 MI ⁽²⁾
Relative Linearity ⁽³⁾	± 0.2 MI ⁽²⁾

Test Circuit #1

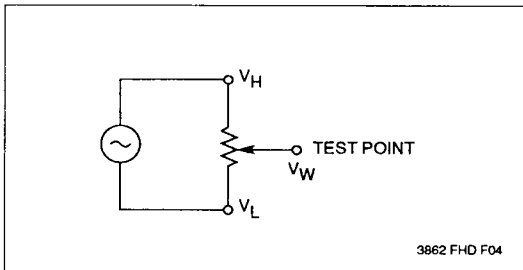

*COMMENT

Stresses above those listed under "Absolute Maximum Ratings" may cause permanent damage to the device. This is a stress rating only and the functional operation of the device at these or any other conditions above those listed in the operational sections of this specification is not implied. Exposure to absolute maximum rating conditions for extended periods may affect device reliability.

Temperature Coefficient

-40°C to +85°C X9311Z	+600 ppm/°C Typical
X9311W, X9311U, X9311T	+300 ppm/°C Typical
Ratiometric Temperature Coefficient	± 20 ppm

Wiper Adjustability

Unlimited Wiper Adjustment (Non-store operation)
Wiper Position Store Operations 10,000 Cycles

Physical Characteristics

Marking Includes

Manufacturer's Trademark
Resistance Value or Code
Date Code

Test Circuit #2

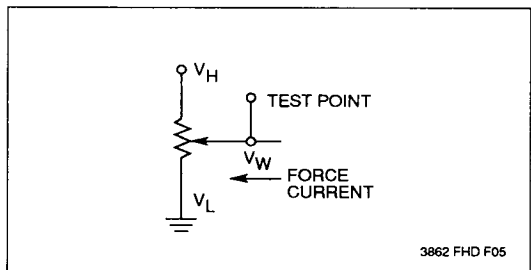

Notes: (1) Absolute Linearity is utilized to determine actual wiper voltage versus expected voltage
 $= (V_{w(n)}(\text{actual}) - V_{w(n)}(\text{expected})) = \pm 1$ MI Maximum.

(2) 1 MI = Minimum Increment = $R_{T01}/99$.

(3) Relative Linearity is a measure of the error in step size between taps = $V_{w(n+1)} - [V_{w(n)} + \text{MI}] = +0.2$ MI.

X9311

D.C. OPERATING CHARACTERISTICS (Over recommended operating conditions unless otherwise specified.)

Symbol	Parameter	Limits			Units	Test Conditions
		Min.	Typ. ⁽⁴⁾	Max.		
I _{CC}	V _{CC} Active Current		1	3	mA	CS = V _{IL} , U/D = V _{IL} or V _{IH} and INC = 0.4V/2.4V @ max. t _{CYC}
I _{SB}	Standby Supply Current		200	500	μA	CS = V _{CC} - 0.3V, U/D and INC = GND or V _{CC} - 0.3V
I _{LI}	CS, INC, U/D Input Leakage Current			±10	μA	V _{IN} = GND to V _{CC}
V _{IH}	CS, INC, U/D Input High Voltage	2.0		V _{CC} + 1.0	V	
V _{IL}	CS, INC, U/D Input Low Voltage	-1.0		0.8	V	
R _W	Wiper Resistance		40	100	Ω	Max. Wiper Current ±1mA
V _{VH}	VH Terminal Voltage	0		10	V	
V _{VL}	VL Terminal Voltage	0		10	V	
C _{IN} ⁽⁵⁾	CS, INC, U/D Input Capacitance			10	pF	V _{CC} = 5.0, V _{IN} = 0V, T _A = 25°C, f = 1 MHz

3862 PGM T05

4

STANDARD PARTS

Part Number	Maximum Resistance	Wiper Increments	Minimum Resistance
X9311Z	1 KΩ	10.1Ω	40Ω
X9311W	10 KΩ	101Ω	40Ω
X9311U	50 KΩ	505Ω	40Ω
X9311T	100 KΩ	1010Ω	40Ω

3862 PGM T08

Notes: (4) Typical values are for T_A = 25°C and nominal supply voltage.

(5) This parameter is periodically sampled and not 100% tested.

X9311

A.C. CONDITIONS OF TEST

Input Pulse Levels	0V to 3.0V
Input Rise and Fall Times	10ns
Input Reference Levels	1.5V

3862 PGM T05

MODE SELECTION

CS	INC	U/D	Mode
L	\setminus	H	Wiper Up
L	\setminus	L	Wiper Down
f	H	X	Store Wiper Position
H	X	X	Standby
f	L	X	No Store, Return to Standby

3862 PGM T06

A.C. OPERATING CHARACTERISTICS (Over recommended operating conditions unless otherwise specified)

Symbol	Parameter	Limits			Units
		Min.	Typ.(6)	Max.	
t_{CI}	CS to INC Setup	100			ns
t_{ID}	INC High to U/D Change	100			ns
t_{DI}	U/D to INC Setup	2.9			μ s
t_{IL}	INC Low Period	1			μ s
t_{IH}	INC High Period	1			μ s
t_{IC}	INC Inactive to CS Inactive	1			μ s
t_{CPH}	CS Deselect Time	20			ms
t_{IW}	INC to V_w Change		100	500	μ s
t_{CYC}	INC Cycle Time	4			μ s
$t_R, t_F^{(7)}$	INC Input Rise and Fall Time			500	μ s
$t_{PU}^{(7)}$	Power up to Wiper Stable			500	μ s
$t_R V_{CC}^{(7)}$	V_{CC} Rise Time	0.5			V/ μ s

3862 PGM T07

A.C. Timing

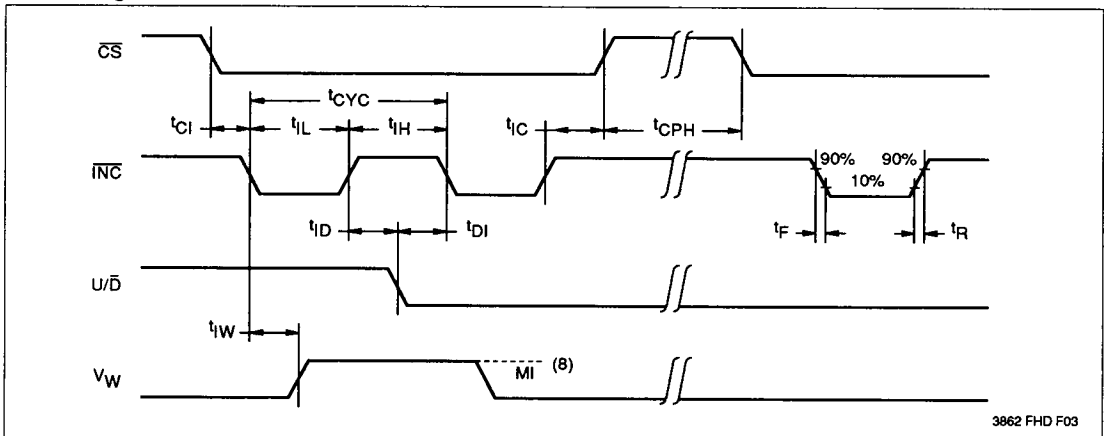

3862 FHD F03

Notes: (6) Typical values are for $T_A = 25^\circ\text{C}$ and nominal supply voltage.

(7) This parameter is periodically sampled and not 100% tested.

(8) MI in the A.C. timing diagram refers to the minimum incremental change in the V output due to a change in the wiper position.