

# Crystal Oscillators - KSS Kinseki

## CMOS PROGRAMMABLE FREQUENCY DIVIDER

### KSS-EXO-3 Series

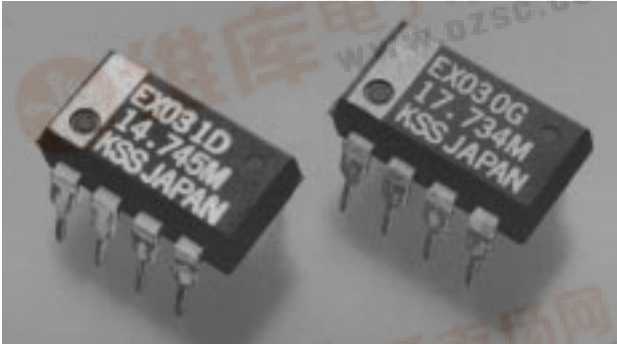

### Dimensions (mm)

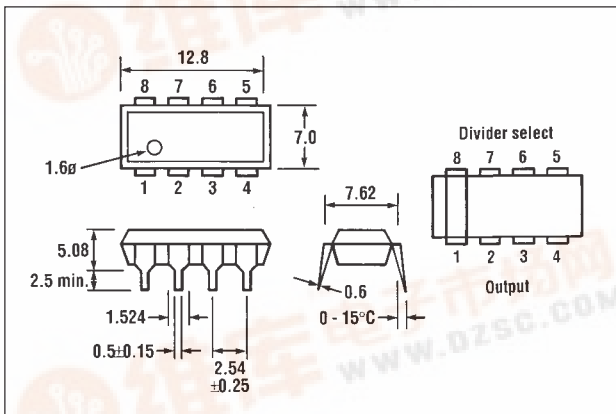

### Pin Connections

#### 1.F

Outputs the original frequency ( $f_0$ ) of the internal quartz crystal.

#### 2.D

Outputs the frequency of programmed dividing ratio ( $f_0/2^n$ ).

#### 3.ST

Possible to be oscillated when set to HIGH level and stopped in oscillation when set to LOW level. When this function is not needed, be sure to set the STANDBY pin to the HIGH level.

#### 4. Gnd

#### 5.A, 6.B & 7.C

Used to program the dividing ratio for the original frequency.

#### 8.V<sub>DD</sub>

### Features

- Frequency range 46.875kHz-20MHz
- Supply voltage range 3 to 6V
- Starting time <1.5ms
- Ultrasonic cleaning is available
- Suitable for various automatic assembly machines
- Low current consumption (CMOS IC structure)
- Standby function included
- High in noise margin
- Usable with no adjustment
- Most frequencies held ex-stock
- SMD version, see Seiko Epson

### Description

The KSS-EXO-3 is a super-small CMOS crystal clock oscillator in an 8-pin dip package equipped with a Programmable Frequency Divider. Division  $1/2$  to  $1/2^8$  simultaneously with the original frequency can be achieved at the user's freedom with this revolutionary device. Composed of an AT-cut oscillator and a specially designed CMOS IC divider, this device realises a wide range of supply voltage, lower power consumption, high speed operation and provides a standby function to meet most of the user's needs. This extraordinary device can utilise various pick & place machinery, replacing traditional oscillators.

### Standard Frequencies Ex-Stock (MHz)

EXO-3C/12.00
EXO-3C/12.288
EXO-3C/12.80
EXO-3C/14.31818
EXO-3C/14.7456
EXO-3C/16.00
EXO-3C/16.384
EXO-3C/17.73447
EXO-3C/19.6608
EXO-3C/20.00
EXO-3C/24.00



# Crystal Oscillators

## CMO-S PROGRAMMABLE FREQUENCY DIVIDER

### KSS-EXO-3 Series Absolute Maximum Ratings

Parameter	Symbol	Specification
Power supply (V)	$V_{DD}$	-0.5 to +7.0V
Input voltage (V)	$V_I$	-0.3 to $V_{DD}$ +0.3V
Output current (mA)	$I_o$	±25mA
Storage Temp. range (°C)	$T_{STG}$	-55 to +125°C

### Operating Conditions

Parameter	Symbol	Specification		
	Dividing ratio			
Supply voltage (V)	$V_{DD}$	3.0V	5.0V	6.0V
Operating temp. range	$T_{OPR}$	-10°C	25°C	70°C

### Characteristics ( $V_{DD} = 5.0V$ , $C_L = 50pF$ , $T_a = 25^\circ C$ )

Parameter	Symbol	Condition	Min.	Typ.	Max.
"H" Input voltage (V)	$V_{IH}$		3.6V		
"L" Input voltage (V)	$V_{IL}$				0.8V
"H" Output voltage (V)	$V_{OH}$	$I_{OUT} = -20\mu A$ $I_{OUT} = 4mA$	4.75V 4.5V		
"L" Output voltage (V)	$V_{OL}$	$I_{OUT} = -20\mu A$ $I_{OUT} = 4mA$			
Output rise time (Sec.)	$T_{TLH}$			10nS	15nS
Output fall time (Sec.)	$T_{TLH}$			10nS	15nS
Input leakage current (A)	$I_I$	$V_{IN} = V_{DD}$ or Gnd			±1.0μA
$V_{DD}$ set up time	$T_{VU}$				1.5mS
ST set up time (Sec.)	$T_{STU}$				1.5mS
Duty ratio (%)	T1/T2		40/60%		60/40%
Power supply current	$I_{DD}$				20.0mA
Standby current	$I_{ST}$				10μA

### Frequency Accuracy

- ACT-EXO-3C = ±100ppm
- ACT-EXO-3D = ±500ppm
- ACT-EXO-3E = ±1000ppm

### Handling Notes

Since this KSS-EXO type crystal clock oscillator employs a CMOS IC integrated with a protection circuit for static electricity, please handle only in an anti static environment.

No by-pass capacitor is inserted between the power supply stage ( $V_{DD}$ -Gnd). To protect from overvoltage and overcurrent due to power supply noise, provide a capacitor (above 0.01μF) as close as possible to the  $V_{DD}$ -Gnd pin.

If  $V_{DD}$  is applied to Pin 4, a Gnd pin, mistaken as Pin 8 ( $V_{DD}$ ), or an inverse current is applied to the device, it causes an internal destruction or no oscillation in some cases. To avoid this, strict care should be taken over correct pin connection.



# Crystal Oscillators

## CMOS PROGRAMMABLE FREQUENCY DIVIDER

### KSS-EX0-3 Series Standard Frequencies

$f_0$ (Original Frequency)			$f_0/2^n$ (Divided Waveform)					
$1/2^0$ (MHz)	$1/2$ (MHz)	$1/2^2$ (MHz)	$1/2^3$ (MHz)	$1/2^4$ (kHz)	$1/2^5$ (kHz)	$1/2^6$ (kHz)	$1/2^7$ (kHz)	$1/2^8$ (kHz)
12.00	6.00	3.00	1.50	750.00	375.00	187.50	93.75	46.875
12.288	6.144	3.072	1.536	768.00	384.00	192.00	96.00	48.00
12.80	6.40	3.20	1.60	800.00	400.00	200.00	100.00	50.00
14.31818	7.15909	3.579545	1.789772	894.88	447.44	223.72	111.875	55.9375
14.7456	7.3728	3.6864	1.8432	921.60	460.80	230.40	115.20	57.60
16.00	8.00	4.00	2.00	1000.00	500.00	250.00	125.00	62.50
17.734476	8.867238	4.433619	2.216809	1108.40	554.20	277.10	138.55	69.275
18.432	9.216	4.608	2.304	1152.00	576.00	288.00	144.00	72.00
19.6608	9.8304	4.9152	2.4576	1228.80	614.40	307.20	153.60	76.80
20.00	10.00	5.00	2.50	1250.00	625.00	312.50	156.25	78.125

### Setting of Dividing Output

Input				Output	
Select	ST	F	D		
C	B	A	(Original frequency)	(Divided waveform)	
X	X	X	L	L	L
L	L	L	H		$F_0/2^1$
L	L	H	H		$F_0/2^2$
L	H	L	H		$F_0/2^3$
L	H	H	H	$f_0$ clock	$F_0/2^4$
H	L	L	H		$F_0/2^5$
H	L	H	H		$F_0/2^6$
H	H	L	H		$F_0/2^7$
H	H	H	H		$F_0/2^8$



# Crystal Oscillators

## CMOS PROGRAMMABLE FREQUENCY DIVIDER

### KSS-EX0-3 Series

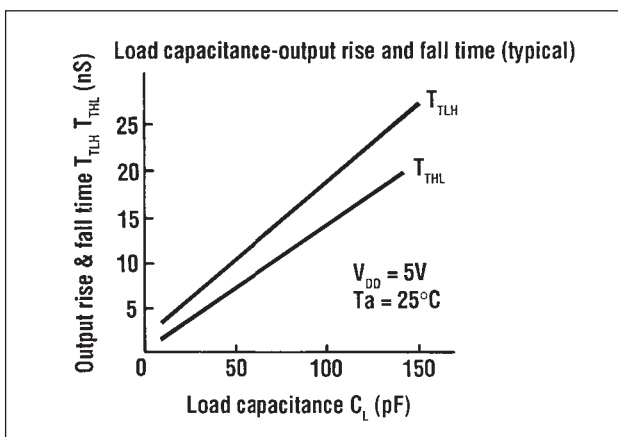
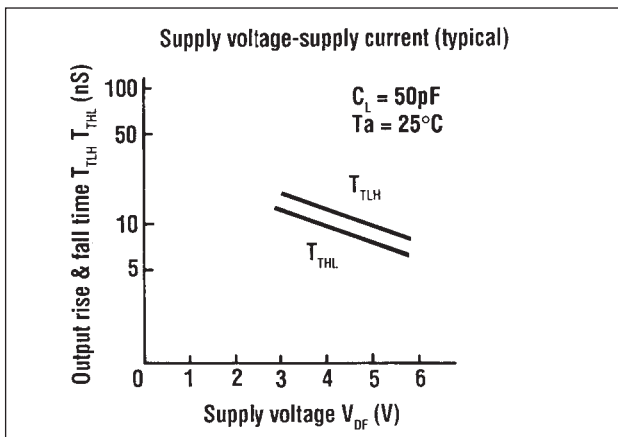
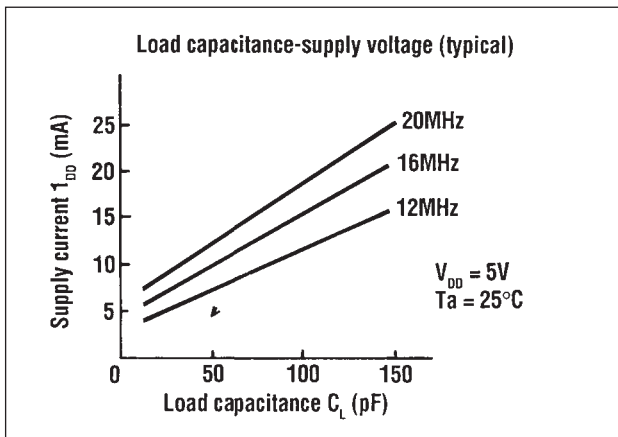
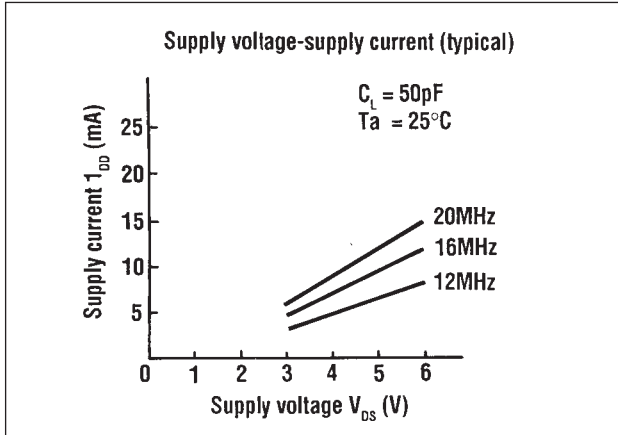

### Environmental and Mechanical Characteristics

Parameter	Description
Shock	100G, 1/2 sine wave, 0.35mS shock pulse, one each to three directions.
Vibration	(1) 10 to 55Hz, amplitude 1.5mm one hour each to three directions (2) 50 to 2000Hz, acceleration 20G one hour each to three directions.
Solder heat resistance	260°C, dip to 1mm from the bottom of mold in soldering tank for 10 secs.
Solvent resistance	Free from problems of appearance and sealing after dipping into Fronsolve for 90 secs.

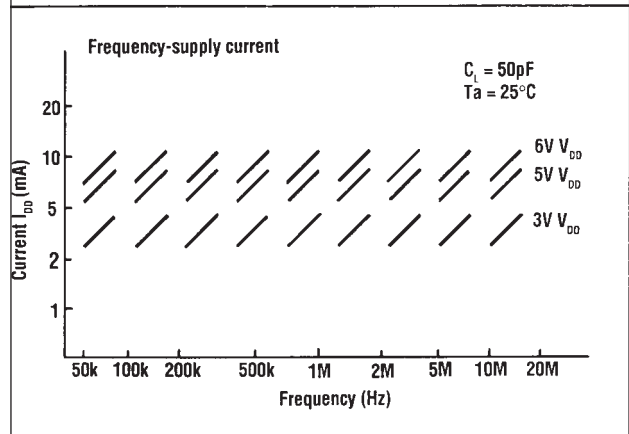
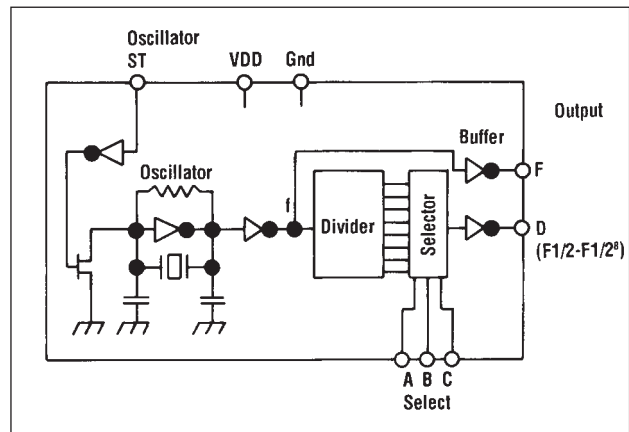

AVAILABLE AVAILABLE  
**EX-**  
STOCK  
AVAILABLE AVAILABLE