



**B240LA**

## Low VF Surface Mount Schottky Barrier Rectifiers

### Features:

- \*Low Surface Mounted Applications
- \*Metal-Semiconductor Junction with Guardring
- \*Epitaxial Construction
- \*Very Low Forward Voltage Drop
- \*High Current Capability
- \*Plastic Material Has UL Flammability Classification 94V-0
- \*For Use in Low Voltage, High Frequency Inverters, Free Wheeling, and Polarity Protection Applications

### Mechanical Data

- \*Case : Molded Plastic
- \*Polarity :Indicated By Cathode Band
- \*Weight : 0.002 ounces, 0.064 grams

**REVERSE VOLTAGE  
40VOLTS  
FORWARD CURRENT  
2.0 AMPERE**



**SMA(DO-214AC)**

## SMA Outline Dimension

unit:mm

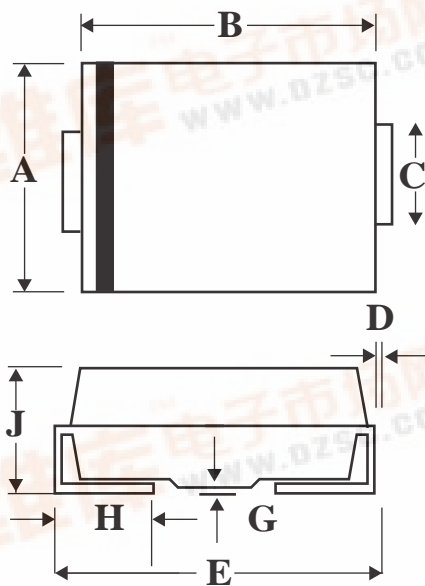

SMA		
Din	Min	Max
A	2.20	2.92
B	4.00	4.60
C	1.27	1.63
D	0.15	0.31
E	4.48	5.59
G	0.10	0.20
H	0.76	1.52
J	1.70	2.62

**B240LA**

## Maximum Ratings and Electrical Characteristics

Rating 25°C Ambient Temperature Unless Otherwise Specified.

Single Phase Half Wave, 60Hz , Resistive or Inductive Load.

For Capacitive Load, Derate Current by 20%.

Characteristics	Symbol	B240LA	Unit
Maximum Recurrent Peak Reverse Voltage	VRRM	40	V
Maximum RMS Voltage	VRMS	28	V
Maximum DC Blocking Voltage	VDC	40	V
Maximum Average Forward Rectified Current @TC=100°C	IF(AV)	2.0	A
Peak Forward Surge Current, 8.3 ms Single Half Sine-Wave Superimposed on Rated Load (JEDEC Method)	IFSM	50	A
Maximum Instantaneous At 2.0A DC	VF	0.40	V
Maximum DC Reverse Current @Tj=25°C At Rated DC Blocking Voltage @Tj=100°C	IR	1.0 50	mA
Typical Junction Capacitance (Note 1)	CJ	200	Pf
Typical Thermal Resistance (Note 2)	RθJC	15	°C/W
Operating Temperature Range	TJ	-55 to+125	°C
Storage Temperature Range	TSTG	-55 to+150	°C

NOTES:1.Measured at 1.0MHz applied reverse voltage of 4.0V DC.

2.Thermal Resistance Junction to case.

**FIG.1- FORWARD CURRENT DERATING CURVE**

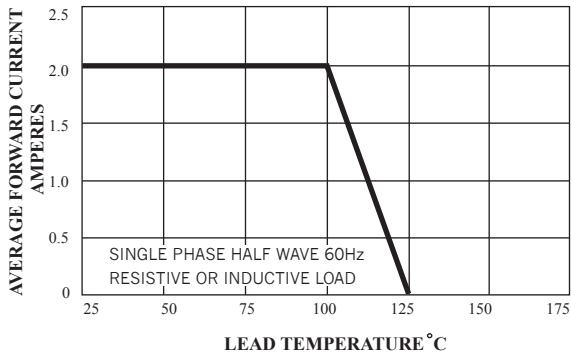

**FIG.2-MAXIMUM NON-REPETITIVE SURGE CURRENT**

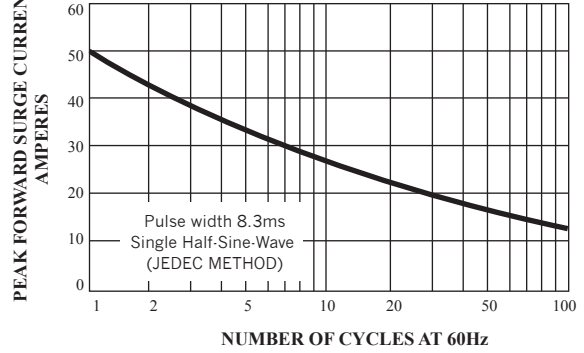

**FIG.3-TYPICAL FORWARD CHARACTERISTICS**

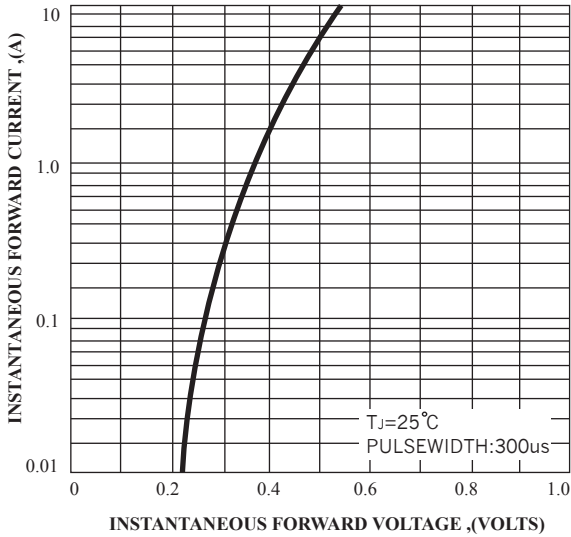

**FIG.4-TYPICAL JUNCTION CAPACITANCE**

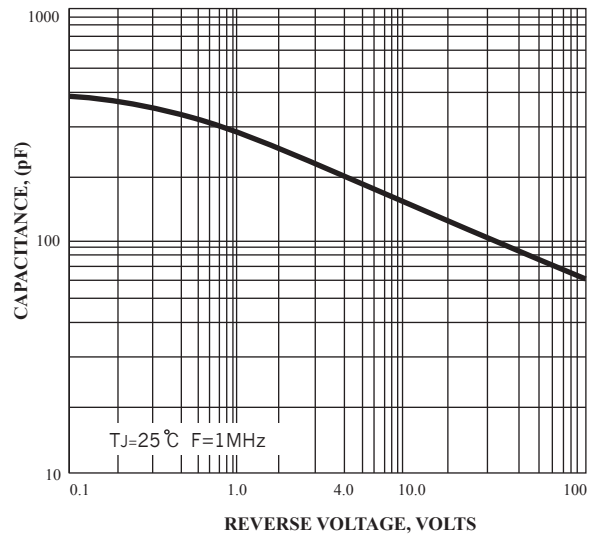

**FIG.5-TYPICAL REVERSE CHARACTERISTICS**

