



STB270N04 STB270N04-1 - STP270N04

N-CHANNEL 40V - 2.1mΩ - 160A - TO-220 - D²PAK - I²PAK
STripFET™ Power MOSFET

General features

Type	V _{DSS}	R _{DS(on)}	I _D	P _{TOT}
STB270N04-1	40V	<2.9mΩ	120A	330W
STB270N04	40V	<2.5mΩ	160A	330W
STP270N04	40V	<2.9mΩ	120A	330W

- 100% avalanche tested
- Standard threshold drive

Description

This N-Channel enhancement mode MOSFET is the latest refinement of STMicroelectronic unique "Single Feature Size™" strip-based process with less critical alignment steps and therefore a remarkable manufacturing reproducibility. The resulting transistor shows extremely high packing density for low on-resistance, rugged avalanche characteristics and low gate charge.

Applications

- High current, switching application
- Automotive

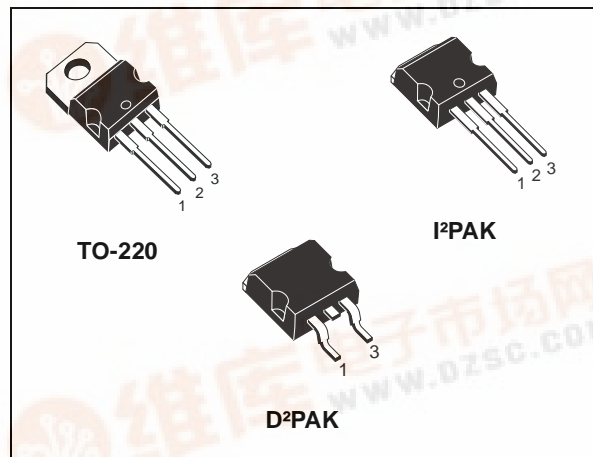

Internal schematic diagram

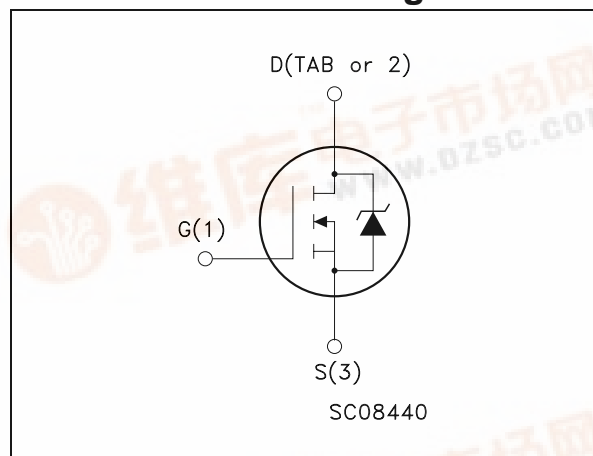

Order codes

Sales Type	Marking	Package	Packaging
STB270N04-1	B270N04	I ² PAK	TUBE
STB270N04	B270N04	D ² PAK	TAPE & REEL
STP270N04	P270N04	TO-220	TUBE



1 Electrical ratings

Table 1. Absolute maximum ratings

Symbol	Parameter	Value		Unit
		TO-220/l ² PAK	D ² PAK	
V _{DS}	Drain-Source Voltage (V _{GS} = 0)	40		V
V _{GS}	Gate-Source Voltage	± 20		V
I _D ⁽¹⁾	Drain Current (continuous) at T _C = 25°C	120	160	A
I _D ⁽¹⁾	Drain Current (continuous) at T _C =100°C	120	160	A
I _{DM} ⁽²⁾	Drain Current (pulsed)	480	640	A
P _{TOT}	Total Dissipation at T _C = 25°C	330		W
	Derating Factor	2.2		W/°C
dv/dt ⁽³⁾	Peak Diode Recovery voltage slope	3.5		V/ns
E _{AS} ⁽⁴⁾	Single Pulse Avalanche Energy	1		J
T _J T _{stg}	Operating Junction Temperature Storage Temperature	-55 to 175		°C

1. Current limited by package
2. Pulse width limited by safe operating area
3. I_{SD} ≤ 120A, di/dt ≤ 200A/μs, V_{DD} ≤ V_{(BR)DSS}, T_J ≤ T_{JMAX}
4. Starting T_J=25°C, I_d =80A, V_{dd}=32V

Table 2. Thermal data

Symbol	Parameter	Value		Unit
		TO-220/l ² PAK	D ² PAK	
R _{thj-case}	Thermal resistance junction-case Max	0.45		°C/W
R _{thj-pcb} ⁽¹⁾	Thermal resistance Junction-pcb Max	--	35	°C/W
R _{thj-a}	Thermal resistance junction-ambient Max	62.5	--	°C/W
T _l	Maximum lead temperature for soldering purpose (for 10 sec, 1.6mm from case)	300	--	°C

1. When mounted on 1inch² FR-4 board, 2 oz Cu.

2 Electrical characteristics

($T_{CASE}=25^{\circ}C$ unless otherwise specified)

Table 3. On/off states

Symbol	Parameter	Test Conditions	Min.	Typ.	Max.	Unit	
$V_{(BR)DSS}$	Drain-Source Breakdown Voltage	$I_D = 250\mu A, V_{GS} = 0$	40			V	
I_{DSS}	Zero Gate Voltage Drain Current ($V_{GS} = 0$)	$V_{DS} = \text{Max Rating},$ $V_{DS} = \text{MaxRating}$ @125°C			10 100	μA μA	
I_{GSS}	Gate Body Leakage Current ($V_{DS} = 0$)	$V_{GS} = \pm 20V$			± 200	nA	
$V_{GS(th)}$	Gate Threshold Voltage	$V_{DS} = V_{GS}, I_D = 250\mu A$	2		4	V	
$R_{DS(on)}$	Static Drain-Source On Resistance	$V_{GS} = 10V, I_D = 80A$	TO-220		2.5	2.9	m Ω
			D ² PAK		2.1	2.5	m Ω

Table 4. Dynamic

Symbol	Parameter	Test Conditions	Min.	Typ.	Max.	Unit
$g_{fs}^{(1)}$	Forward Transconductance	$V_{DS} = 15V, I_D = 80A$		200		S
C_{iss}	Input Capacitance	$V_{DS} = 25V, f = 1 \text{ MHz}, V_{GS} = 0$		7400		pF
C_{oss}	Output Capacitance			1800		pF
C_{rss}	Reverse Transfer Capacitance			47		pF
Q_g	Total Gate Charge	$V_{DD} = 20V, I_D = 160A$		110	150	nC
Q_{gs}	Gate-Source Charge	$V_{GS} = 10V$		27		nC
Q_{gd}	Gate-Drain Charge	(see Figure 2)		25		nC

1. Pulsed: pulse duration=300 μs , duty cycle 1.5%

Table 5. Switching times

Symbol	Parameter	Test Conditions	Min.	Typ.	Max.	Unit
$t_{d(on)}$ t_r	Turn-on Delay Time Rise Time	$V_{DD}=20\text{ V}$, $I_D=80\text{ A}$, $R_G=4.7\Omega$, $V_{GS}=10\text{ V}$ (see Figure 14)		22 180		ns ns
$t_{d(off)}$ t_f	Turn-off Delay Time Fall Time	$V_{DD}=20\text{ V}$, $I_D=80\text{ A}$, $R_G=4.7\Omega$, $V_{GS}=10\text{ V}$ (see Figure 14)		110 45		ns ns

Table 6. Source drain diode

Symbol	Parameter		Test Conditions	Min	Typ.	Max	Unit
I_{SD}	Source-drain Current	D ² PAK				160	A
		TO-220 I ² PAK				120	A
$I_{SDM}^{(1)}$	Source-drain Current (pulsed)	D ² PAK				640	A
		TO-220 I ² PAK				480	A
$V_{SD}^{(2)}$	Forward on Voltage		$I_{SD}=80\text{ A}$, $V_{GS}=0$			1.5	V
t_{rr}	Reverse Recovery Time		$I_{SD}=160\text{ A}$, $di/dt = 100\text{ A}/\mu\text{s}$, $V_{DD}=32\text{ V}$, $T_j=150^\circ\text{C}$		70		ns
Q_{rr}	Reverse Recovery Charge				225		nC
I_{RRM}	Reverse Recovery Current				3.2		A

1. Pulse width limited by safe operating area
2. Pulsed: pulse duration=300 μs , duty cycle 1.5%

2.1 Electrical characteristics (curves)

Figure 1. Safe operating area

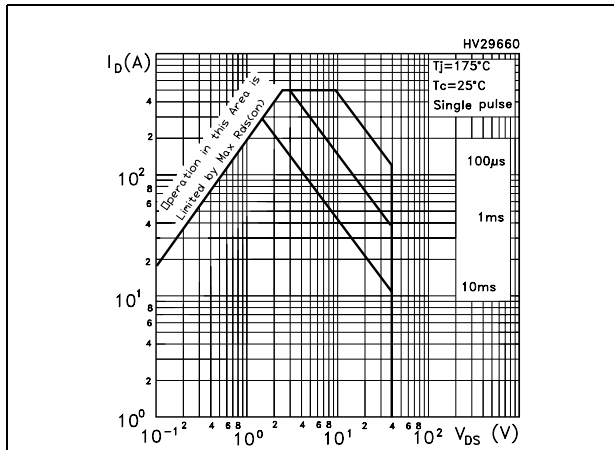

Figure 2. Thermal impedance

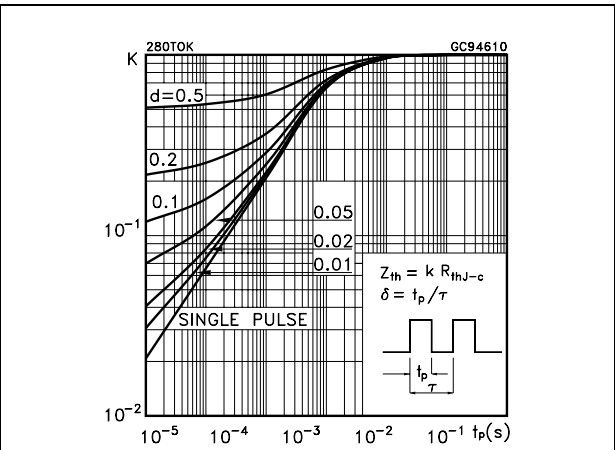

Figure 3. Output characteristics

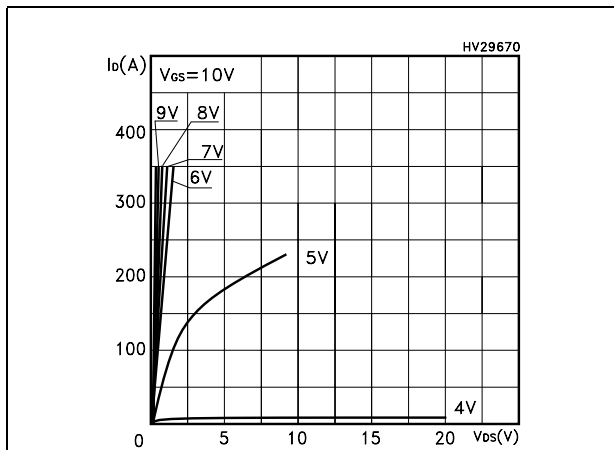

Figure 4. Transfer characteristics

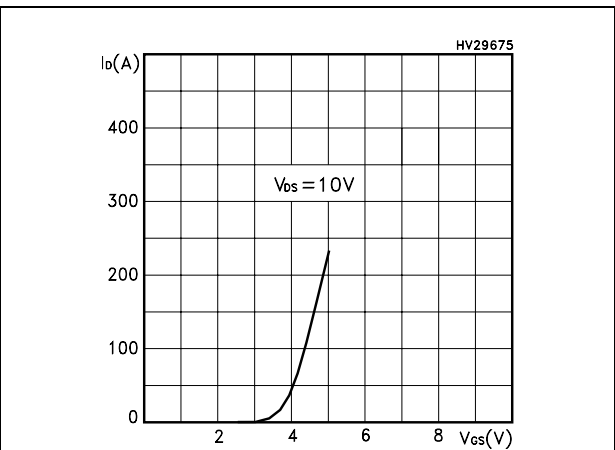

Figure 5. Static drain-source on resistance

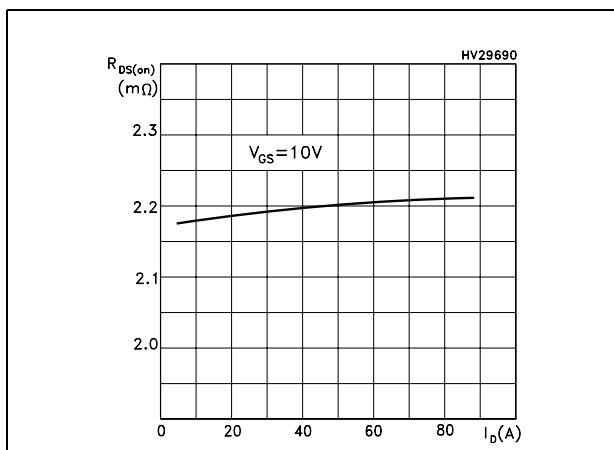

Figure 6. Normalized B_{VDS} vs temperature

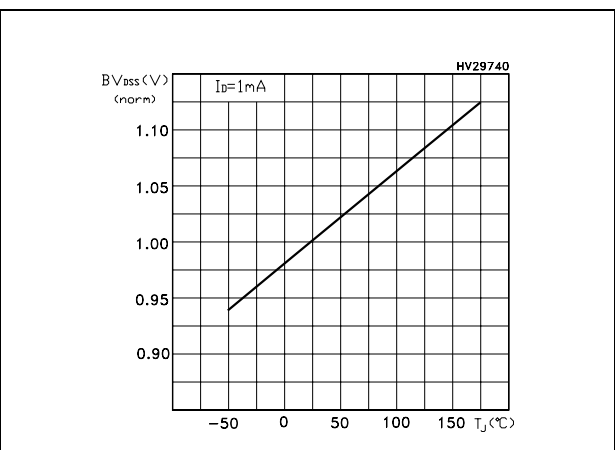

Figure 7. Gate charge vs gate-source voltage Figure 8. Capacitance variations

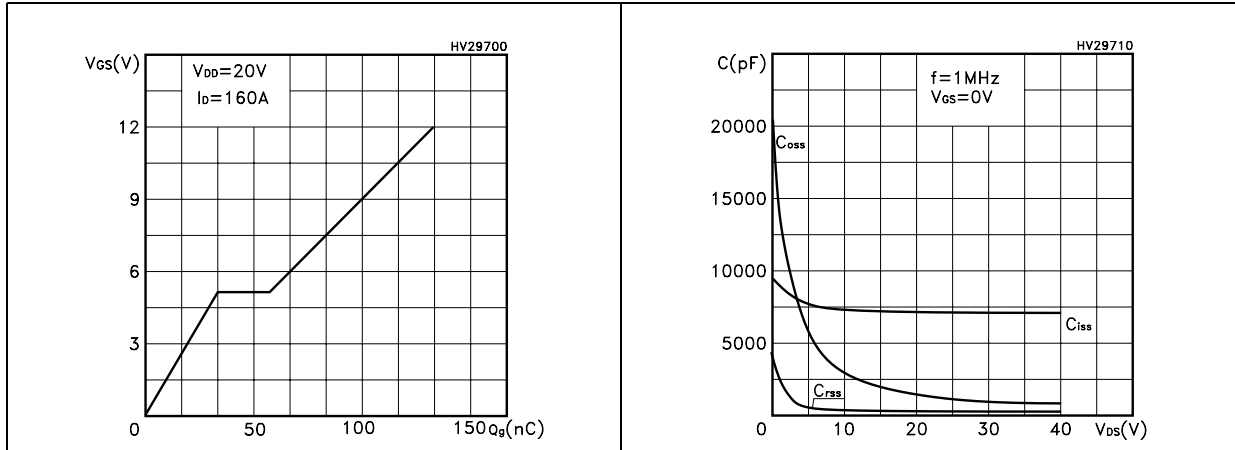

Figure 9. Normalized gate threshold voltage vs temperature Figure 10. Normalized on resistance vs temperature

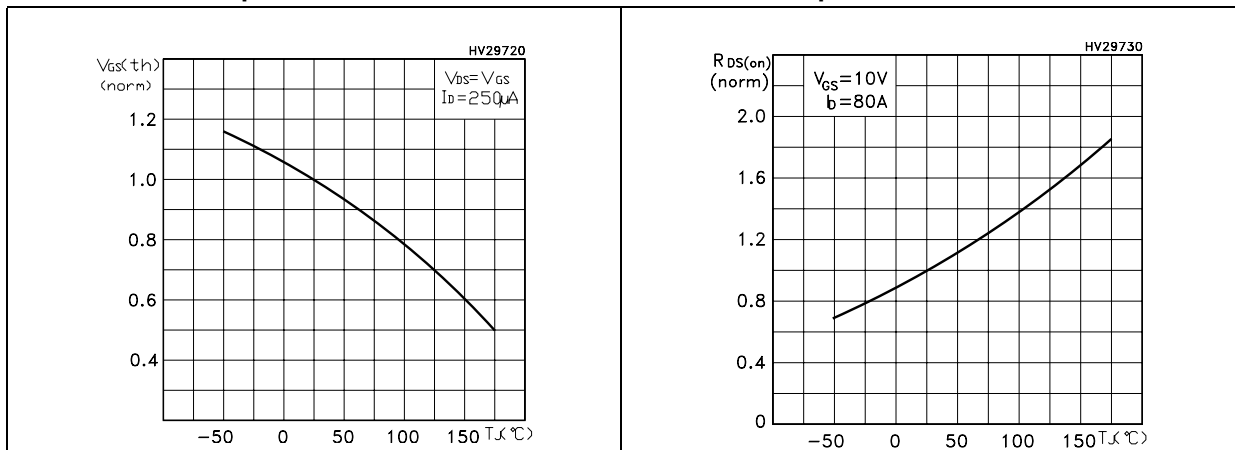
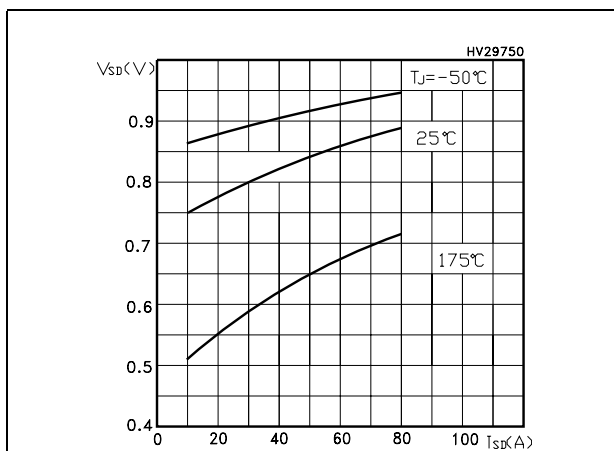

Figure 11. Source-drain diode forward characteristics



3 Test circuit

Figure 12. Switching times test circuit for resistive load

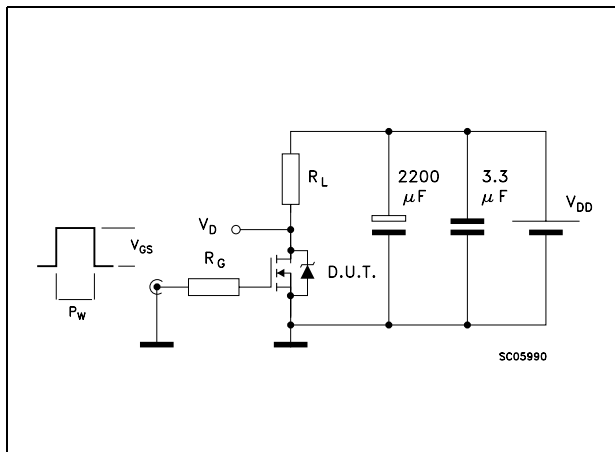

Figure 13. Gate charge test circuit

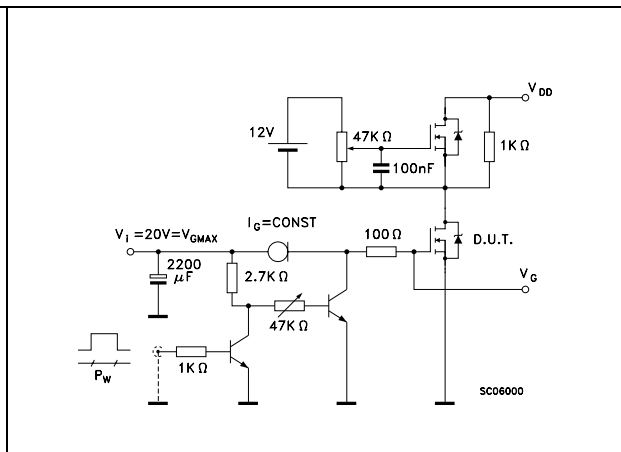

Figure 14. Test circuit for inductive load switching and diode recovery times

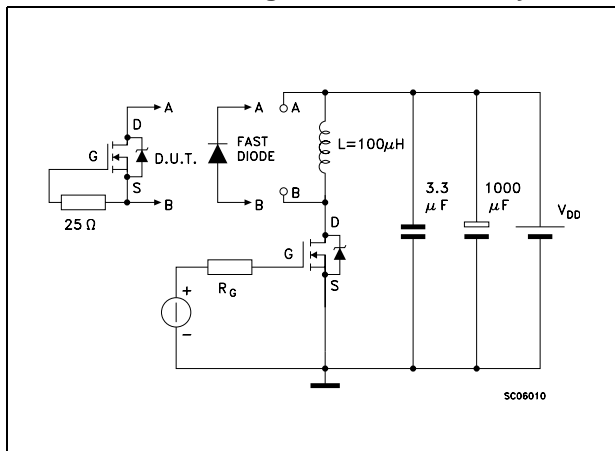

Figure 15. Unclamped Inductive load test circuit

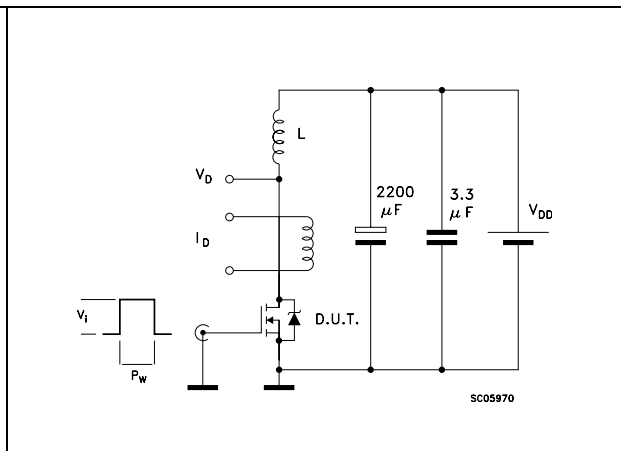

Figure 16. Unclamped inductive waveform

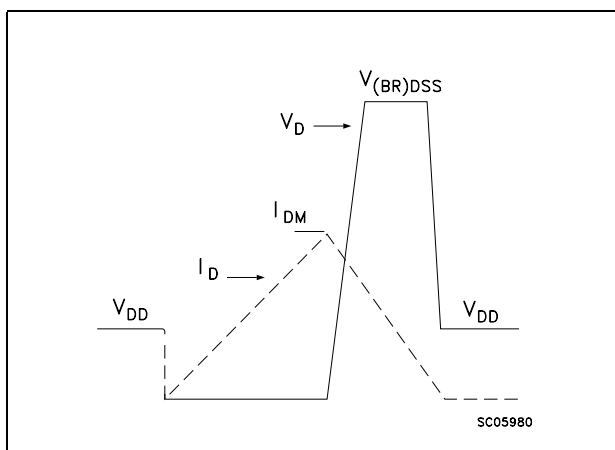
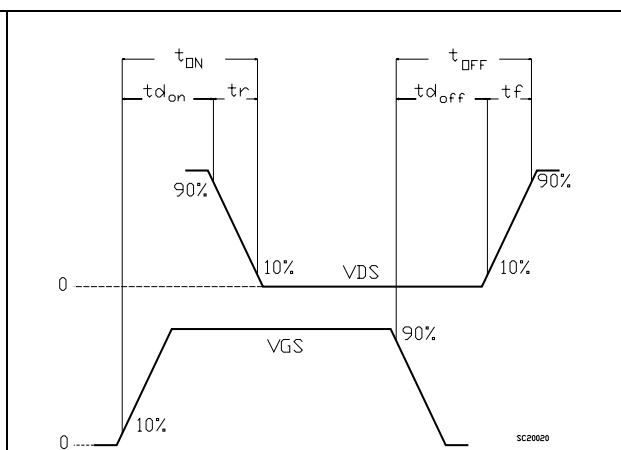

Figure 17. Switching time waveform



4 Package mechanical data

In order to meet environmental requirements, ST offers these devices in ECOPACK® packages. These packages have a Lead-free second level interconnect . The category of second level interconnect is marked on the package and on the inner box label, in compliance with JEDEC Standard JESD97. The maximum ratings related to soldering conditions are also marked on the inner box label. ECOPACK is an ST trademark. ECOPACK specifications are available at: www.st.com

TO-220 MECHANICAL DATA

DIM.	mm.			inch		
	MIN.	TYP.	MAX.	MIN.	TYP.	MAX.
A	4.40		4.60	0.173		0.181
b	0.61		0.88	0.024		0.034
b1	1.15		1.70	0.045		0.066
c	0.49		0.70	0.019		0.027
D	15.25		15.75	0.60		0.620
E	10		10.40	0.393		0.409
e	2.40		2.70	0.094		0.106
e1	4.95		5.15	0.194		0.202
F	1.23		1.32	0.048		0.052
H1	6.20		6.60	0.244		0.256
J1	2.40		2.72	0.094		0.107
L	13		14	0.511		0.551
L1	3.50		3.93	0.137		0.154
L20		16.40			0.645	
L30		28.90			1.137	
øP	3.75		3.85	0.147		0.151
Q	2.65		2.95	0.104		0.116

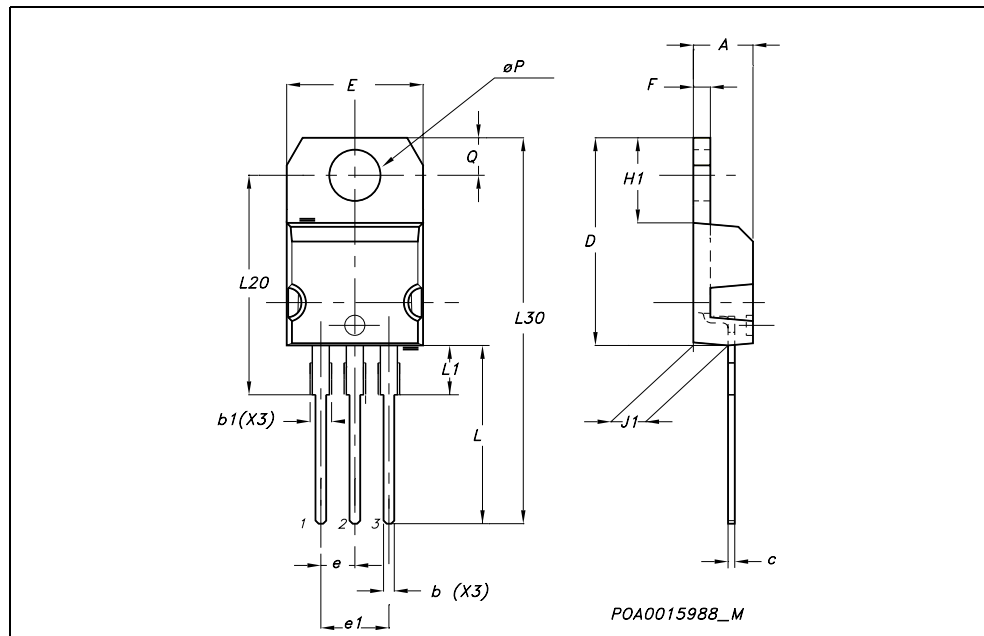

TO-262 (I²PAK) MECHANICAL DATA

DIM.	mm.			inch		
	MIN.	TYP.	MAX.	MIN.	TYP.	MAX.
A	4.40		4.60	0.173		0.181
A1	2.40		2.72	0.094		0.107
b	0.61		0.88	0.024		0.034
b1	1.14		1.70	0.044		0.066
c	0.49		0.70	0.019		0.027
c2	1.23		1.32	0.048		0.052
D	8.95		9.35	0.352		0.368
e	2.40		2.70	0.094		0.106
e1	4.95		5.15	0.194		0.202
E	10		10.40	0.393		0.410
L	13		14	0.511		0.551
L1	3.50		3.93	0.137		0.154
L2	1.27		1.40	0.050		0.055

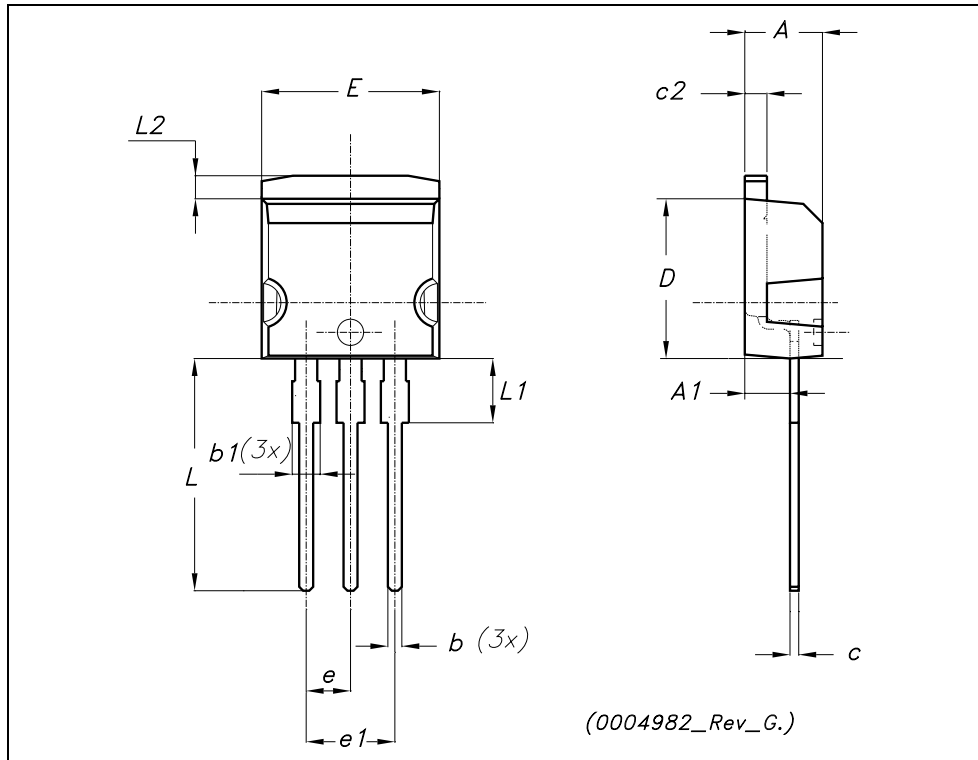

D²PAK MECHANICAL DATA

DIM.	mm.			inch		
	MIN.	TYP.	MAX.	MIN.	TYP.	MAX.
A	4.4		4.6	0.173		0.181
A1	2.49		2.69	0.098		0.106
A2	0.03		0.23	0.001		0.009
B	0.7		0.93	0.027		0.036
B2	1.14		1.7	0.044		0.067
C	0.45		0.6	0.017		0.023
C2	1.23		1.36	0.048		0.053
D	8.95		9.35	0.352		0.368
D1		8			0.315	
E	10		10.4	0.393		
E1		8.5			0.334	
G	4.88		5.28	0.192		0.208
L	15		15.85	0.590		0.625
L2	1.27		1.4	0.050		0.055
L3	1.4		1.75	0.055		0.068
M	2.4		3.2	0.094		0.126
R		0.4			0.015	
V2	0°		4°			

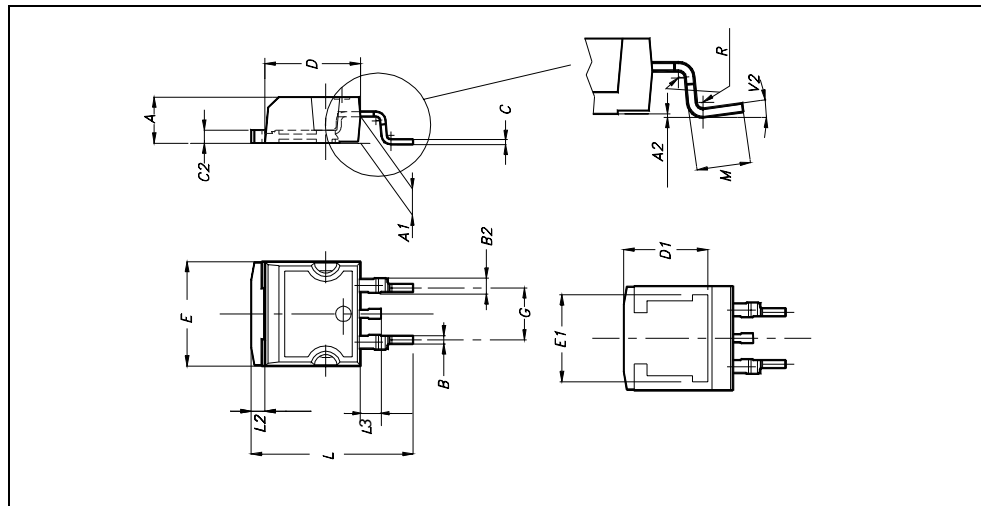

5 Packaging mechanical data

D²PAK FOOTPRINT

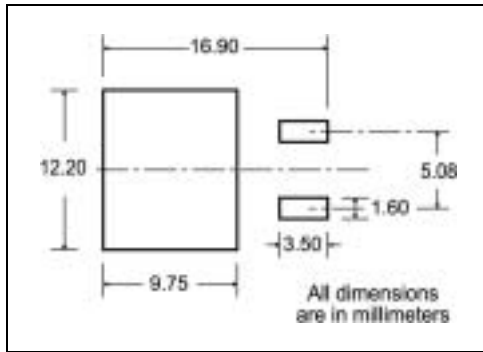

TAPE AND REEL SHIPMENT

40 mm min. Access hole at slot location

Full radius

Tape slot in core for tape start 25mm min. width

REEL MECHANICAL DATA

DIM.	mm		inch	
	MIN.	MAX.	MIN.	MAX.
A		330		12.992
B	1.5		0.059	
C	12.8	13.2	0.504	0.520
D	20.2		0.795	
G	24.4	26.4	0.960	1.039
N	100		3.937	
T		30.4		1.197

BASE QTY	BULK QTY
1000	1000

TAPE MECHANICAL DATA

DIM.	mm		inch	
	MIN.	MAX.	MIN.	MAX.
A0	10.5	10.7	0.413	0.421
B0	15.7	15.9	0.618	0.626
D	1.5	1.6	0.059	0.063
D1	1.59	1.61	0.062	0.063
E	1.65	1.85	0.065	0.073
F	11.4	11.6	0.449	0.456
K0	4.8	5.0	0.189	0.197
P0	3.9	4.1	0.153	0.161
P1	11.9	12.1	0.468	0.476
P2	1.9	2.1	0.075	0.082
R	50		1.574	
T	0.25	0.35	0.0098	0.0137
W	23.7	24.3	0.933	0.956

10 pitches cumulative tolerance on tape +7 -0.2 mm

Center line of cavity

User Direction of Feed

TRL

FEED DIRECTION

Bending radius R min.

* on sales type

6 Revision history

Table 7. Document revision history

Date	Revision	Changes
07-Oct-2005	1	Initial release.
10-Nov-2005	2	Preliminary version
09-Feb-2006	3	Complete datasheet

Information furnished is believed to be accurate and reliable. However, STMicroelectronics assumes no responsibility for the consequences of use of such information nor for any infringement of patents or other rights of third parties which may result from its use. No license is granted by implication or otherwise under any patent or patent rights of STMicroelectronics. Specifications mentioned in this publication are subject to change without notice. This publication supersedes and replaces all information previously supplied. STMicroelectronics products are not authorized for use as critical components in life support devices or systems without express written approval of STMicroelectronics.

The ST logo is a registered trademark of STMicroelectronics.
All other names are the property of their respective owners

© 2006 STMicroelectronics - All rights reserved

STMicroelectronics group of companies

Australia - Belgium - Brazil - Canada - China - Czech Republic - Finland - France - Germany - Hong Kong - India - Israel - Italy - Japan -
Malaysia - Malta - Morocco - Singapore - Spain - Sweden - Switzerland - United Kingdom - United States of America

www.st.com