



NIPPON PRECISION CIRCUITS INC.

SM9501A/B

Radio Controlled Clock Receiver IC

OVERVIEW

The SM9501A/B is a BiCMOS RCC^{*1} receiver IC. It accepts low frequency standard wave input received from an external antenna, amplifies it, detects the data signal, and outputs a digital time code signal.

*1: Radio controlled clock

FEATURES

- Operating supply voltage range
 - 2.4 to 3.6V (A version)
 - 4.5 to 5.5V (B version)
- Operating current consumption
 - 55μA (typ) @3V (A version)
 - 55μA (typ) @5V (B version)
- Standby current consumption
 - 0.1μA (max) @3V (A version)
 - 0.1μA (max) @5V (B version)
- High sensitivity: 0.5μVrms input
- Wide frequency range (35kHz to 80kHz)
- Include analog switch for antenatuning capacitors change
- AGC gain hold function
- External crystal filter connection
- BiCMOS process
- Package:16-pin VSOP, Chip form

PINOUT

(Top view)

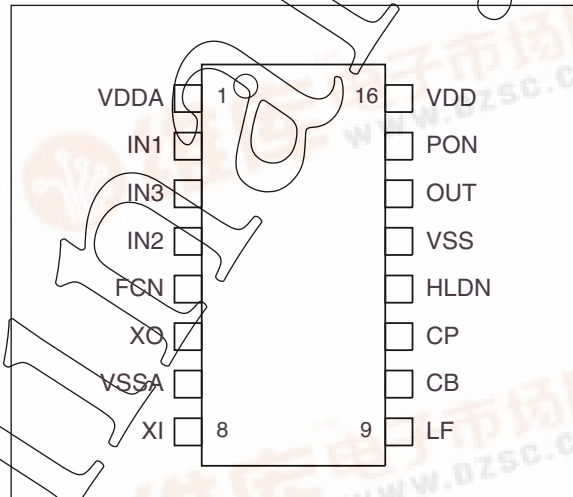

ORDERING INFORMATION

Device	Package
SM9501AV	16-pin VSOP
SM9501BV	
CF9501A	Chip form

PACKAGE DIMENSIONS

(Unit: mm)

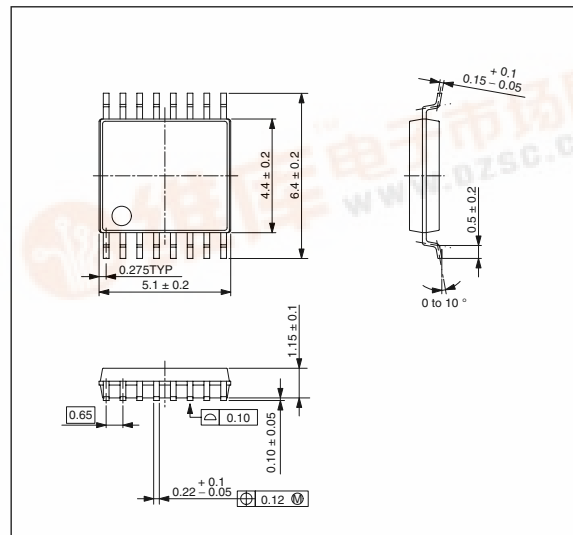

PRELIMINARY



SM9501A/B

PAD LAYOUT (CF9501A)

(Unit: μm)

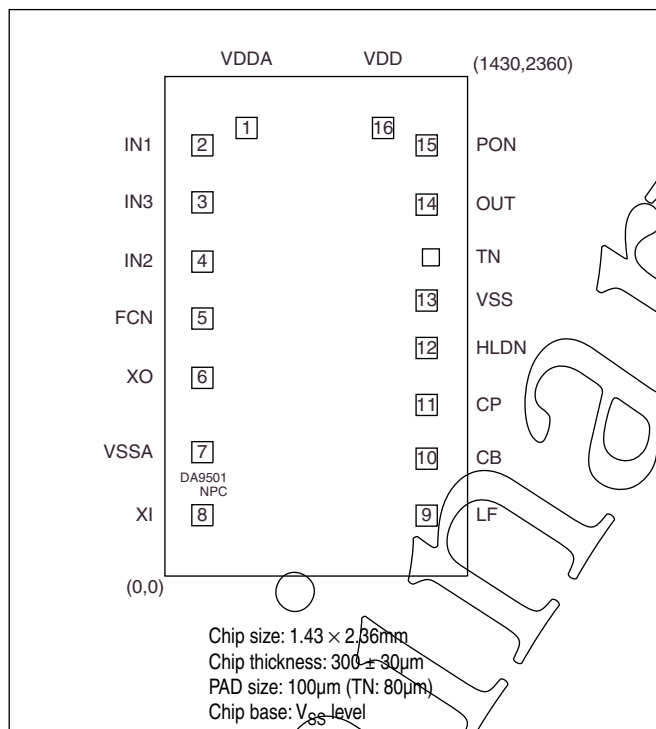

PAD NAME and DIMENSIONS (CF9501A)

Number	Name	Pad dimensions [μm]	
		X	Y
1	VDDA	386	2117
2	IN1	177	2035
3	IN3	177	1766
4	IN2	177	1486
5	FCN	177	1217
6	XO	177	937
7	VSSA	177	586
8	XI	177	288
9	LF	1237	286
10	CB	1237	555
11	CP	1237	809
12	HLDN	1237	1078
13	VSS	1237	1302
14	OUT	1237	1755
15	PON	1237	2035
16	VDD	1031	2117
-	TN ¹	1257	1506

1. For test mode

BLOCK DIAGRAM

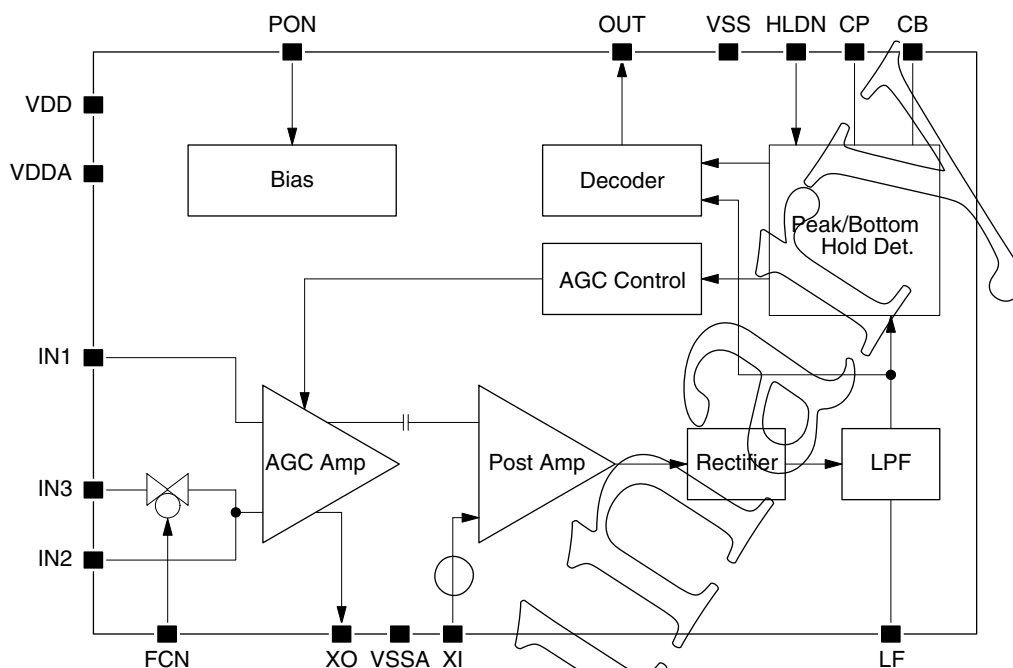

PIN DESCRIPTION

Number	Name	I/O ¹	A/D ²	Description
1	VDDA		A	AGC amplifier (+) supply input
2	IN1		A	Antenna input 1 (fixed input)
3	IN3		A	Antenna input 3 (via analog switch)
4	IN2		A	Antenna input 2 (analog switch bypass)
5	FCN		D	Analog switch control input (active LOW)
6	XO		A	Output for crystal filter
7	VSSA		A	AGC amplifier (-) supply input
8	XI		A	Input from crystal filter
9	LF		A	Rectifier LPF capacitor connection
10	CB		A	Bottom hold detector capacitor connection
11	CP		A	Peak hold detector capacitor connection
12	HLDN		D	AGC gain hold control (active LOW)
13	VSS		A	Substrate (-) supply input
14	OUT		D	Clock time code output (active LOW)
15	PON		D	Standby state control input (active LOW)
16	VDD		A	(+) supply input
-	TN		D	AGC amplifier gain control switch (active LOW, for test mode)

1. I: input, O: output, lpu: input with pull-up resistor, -: supply pin
 2. A: analog signal, D: digital signal

SPECIFICATIONS

Absolute Maximum Ratings

$V_{SS} = 0V$

Parameter	Symbol	Condition	Rating	Unit
Supply voltage range	V_{DD}		-0.3 to +7.0	V
Input voltage range	V_{IN}		-0.3 to $V_{DD}+0.3$	V
Power dissipation	P_D	16-pin VSOP	150	mW
Storage temperature range	T_{stg}	16-pin VSOP	-65 to +125	°C
		Chip form	-65 to +150	°C

Recommended Operating Conditions

$V_{SS} = 0V$

Parameter	Symbol	Condition	Rating	Unit
Supply voltage range	V_{DD}	A version	2.4 to 3.6	V
		B version	4.5 to 5.5	V
Operating temperature range	T_{opr}	A version	-20 to +70	°C
		B version	-40 to +85	°C

Preliminary

SM9501A/B

Electrical Characteristics

9501A version

$V_{DD} = 2.4$ to $3.6V$, $V_{SS} = 0V$, $T_a = -20$ to $+70^\circ C$ unless otherwise noted.

Parameter	Symbol	Condition	Rating			Unit
			min	typ	max	
Minimum operating voltage	V_{MIN}		-	-	2.4	V
Maximum operating voltage	V_{MAX}		3.6	-	-	V
Maximum operating current consumption ¹	I_{DDM}	$V_{DD} = 3.0V$, no input signal, PON: VSS, OUT: OPEN	-	65	100	μA
Operating current consumption ¹	I_{DDT}	$V_{DD} = 3.0V$, 500ms pulsewidth, 0.1mVrms input (differential input), PON: VSS, OUT: OPEN	-	55	-	μA
Standby mode current consumption	I_{ST}	PON, FCN, HLDN: VDD or OPEN	-	-	0.1	μA
Minimum input voltage range	V_{FMIN}	IN1-IN2 differential input	-	0.5	1.0	μV_{rms}
Maximum input voltage range	V_{FMAX}	IN1-IN2 differential input	80	-	-	mVrms
Input frequency	F_{IN}	IN1-IN2 differential input	35	-	80	kHz
Analog switch resistance	R_A	$V_{IN2-3} = 50mV$, $V_{IN2} = 0V$	-	-	15	Ω
Startup time ²	t_{ON}	When supply is applied	-	-	8	sec
Startup time ² (PON)	t_{PON}	From standby mode	-	-	8	sec
PON input current	I_{I1}	$V_{IN} = 0V$	-	-	-1.5	μA
FCN input current	I_{I2}	$V_{IN} = 0V$	-	-	-1.5	μA
HLDN input current	I_{I3}	$V_{IN} = 0V$	-	-	-1.5	μA
LOW-level output current	I_{OL}	$V_{DD} = 2.4V$, OUT = 0.5V	10	-	-	μA
HIGH-level output current	I_{OH}	$V_{DD} = 2.4V$, OUT = 1.9V	-10	-	-	μA
Gain hold time	t_{HLD}	$\pm 3dB$ change	-	-	1	sec
Fall time output propagation delay ³	t_{DN}		-	-	160	ms
Rise time output propagation delay ³	t_{UP}		-	-	200	ms
LOW-level output pulsewidth ⁴ (200ms)	T_{200}	$F_{IN} = 40/60kHz$, standard crystal, NPC standard jig $V_{IN} = 1\mu V_{rms}$ to 80mVrms	100	200	300	ms
LOW-level output pulsewidth ⁴ (500ms)	T_{500}		400	500	650	ms
LOW-level output pulsewidth ⁴ (800ms)	T_{800}		700	800	900	ms
Noise rejection ratio ⁵	S/N		-	-	9	dB

1. Measured using the standard circuit.
2. The time taken under stable wave input conditions from when power is applied or standby is released, using PON, until stable digital output occurs within ratings.
3. The time taken, with 10:1 input signal amplitude ratio and 500ms pulsewidth, from when a change in signal input occurs until the output OUT changes. Note that this characteristic is very dependent on the antenna and crystal filter characteristics. The standard crystal used here has the following equivalent circuit coefficients:

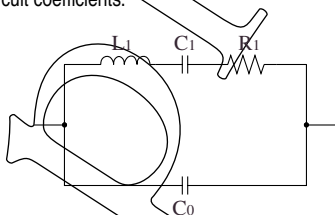

f [kHz]	L1 [kH]	C1 [fF]	R1 [k Ω]	C0 [pF]
40	6.70280	2.36228	11.4492	1.42773
60	5.17396	1.36007	13.4826	1.04927

4. Values obtained when using the standard crystal employed here. Note that these values are dependent on the crystal characteristics, and should be considered as reference values.
5. Time averaged rms values, where the noise is white noise and the measurement bandwidth is determined by the crystal filter equivalent used in the standard circuit.

SM9501A/B

9501B version

$V_{DD} = 4.5$ to $5.5V$, $V_{SS} = 0V$, $T_a = -40$ to $+85^\circ C$ unless otherwise noted.

Parameter	Symbol	Condition	Rating			Unit
			min	typ	max	
Supply voltage	V_{DD}		4.5	5.0	5.5	V
Maximum operating current consumption ¹	I_{DDM}	$V_{DD} = 5.0V$, $T_a = 25^\circ C$, no input signal, PON: VSS, OUT: OPEN	-	65	100	μA
Operating current consumption ¹	I_{DDT}	$V_{DD} = 5.0V$, $T_a = 25^\circ C$, 500ms pulsewidth, 0.1mVrms input (differential input), PON: VSS, OUT: OPEN	-	55	-	μA
Standby mode current consumption	I_{ST}	PON: VDD or OPEN, FCN: VDD or OPEN, HLDN: VDD or OPEN	-	-	0.1	μA
Minimum input voltage range	V_{FMIN}	IN1-IN2 differential input, $F_{IN} = 40kHz, 60kHz$, $T_a = 25^\circ C$	-	0.5	1.0	μV_{rms}
Maximum input voltage range	V_{FMAX}	IN1-IN2 differential input, $F_{IN} = 40kHz, 60kHz$	80	-	-	mVrms
Input frequency	F_{IN}	IN1-IN2 differential input	35	-	80	kHz
Analog switch resistance	R_A	$V_{IN2} = 0V$, $V_{IN3} = 50mV$	-	-	15	Ω
Startup time ²	t_{ON}	When supply is applied	-	-	8	sec
Startup time ² (PON)	t_{PON}	From standby mode	-	-	8	sec
Gain hold time	t_{HLD}	$\pm 3dB$ change	1	-	-	sec
Input voltage	V_{IL}	PON, FCN, HLDN pins	-	-	0.5	V
	V_{IH}	PON, FCN, HLDN pins	$0.8V_{DD}$	-	-	V
Input current	I_{IL}	$V_{IL} = 0V$, PON, FCN, HLDN pins	-	-	-3.2	μA
	I_{IH}	$V_{IH} = V_{DD}$, PON, FCN, HLDN pins	-	-	0.1	μA
LOW-level output current	I_{OL}	$V_{DD} = 4.5V$, OUT = 0.5V	10	-	-	μA
HIGH-level output current	I_{OH}	$V_{DD} = 4.5V$, OUT = 4.0V	-10	-	-	μA
Fall time output propagation delay ³	t_{DN}		-	-	160	ms
Rise time output propagation delay ³	t_{UP}		-	-	200	ms
LOW-level output pulsewidth ⁴ (200ms)	T_{200}	$F_{IN} = 40/60kHz$, standard crystal, NPC standard jig	100	200	300	ms
LOW-level output pulsewidth ⁴ (500ms)	T_{500}	$V_{IN} = 1\mu V_{rms}$ to 80mVrms	400	500	650	ms
LOW-level output pulsewidth ⁴ (800ms)	T_{800}		700	800	900	ms
Noise rejection ratio ⁵	S/N		-	-	9	dB

1. Measured using the standard circuit.
2. The time taken under stable wave input conditions from when power is applied or standby is released, using PON, until stable digital output occurs within ratings.
3. The time taken, with 10:1 input signal amplitude ratio and 500ms pulsewidth, from when a change in signal input occurs until the output OUT changes. Note that this characteristic is very dependent on the antenna and crystal filter characteristics. The standard crystal used here has the following equivalent circuit coefficients

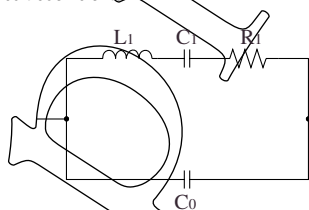

f [kHz]	L1 [kH]	C1 [fF]	R1 [k Ω]	C0 [pF]
40	6.70280	2.36228	11.4492	1.42773
60	5.17396	1.36007	13.4826	1.04927

4. Values obtained when using the standard crystal employed here. Note that these values are dependent on the crystal characteristics, and should be considered as reference values.
5. Time averaged rms values, where the noise is white noise and the measurement bandwidth is determined by the crystal filter equivalent used in the standard circuit.

STANDARD CIRCUIT

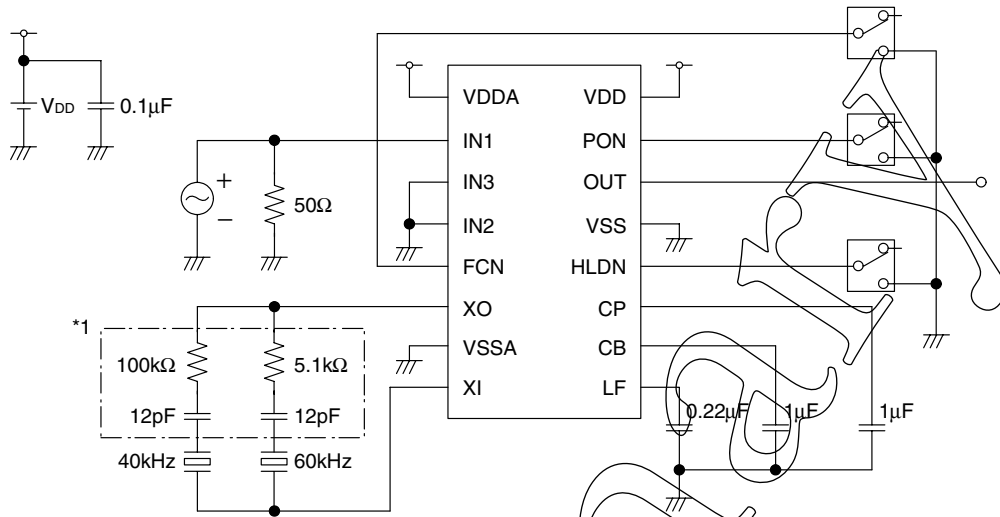

*1. These values are obtained when using NPC's standard crystal and should be considered as reference values. In case of using differnt crystal, the values are different.

APPLICATION CIRCUIT

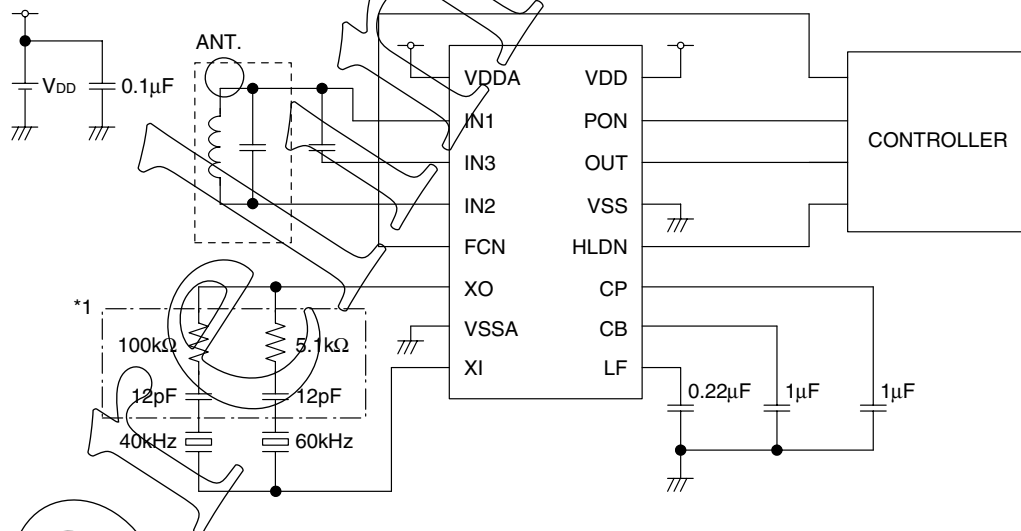

*1. These values are obtained when using NPC's standard crystal and should be considered as reference values. In case of using differnt crystal, the values are different.

FUNCTIONAL DESCRIPTION

Antenna Input and Tuning Capacitor Switching Function

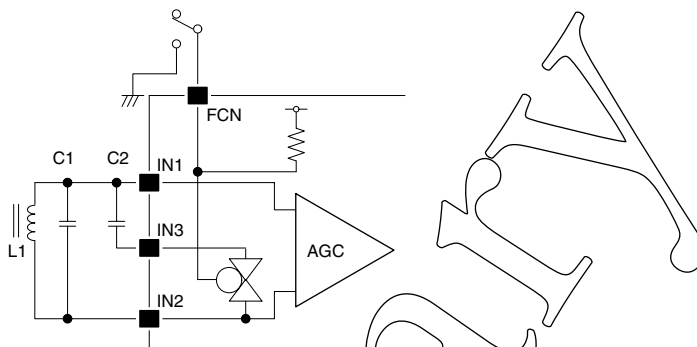

There are three antenna inputs: IN1, IN2, and IN3. When FCN is open (or HIGH), the internal analog switch is OFF and IN1–IN2 are the antenna inputs (60kHz mode). When FCN is LOW, the analog switch is ON, connecting IN3 and IN2. C2 is then connected in parallel to C1 in the tuning circuit, reducing the resonant frequency (40kHz mode).

FCN	Analog switch	Antenna input	Tuning capacitor	Receiver frequency
Open or HIGH	OFF	Between IN1 and IN2	C1	60kHz
LOW	ON	Between IN1 and IN2, IN3	C1 + C2 parallel	40kHz

FCN should be left open if not using the tuning capacitor switching function, and IN2 should be connected to IN3 externally.

AGC Amplifier and Gain Hold Function

The input voltage from the antenna is amplified by the AGC amplifier. The gain can be monitored by the voltage on pin CP, and can be changed by varying the CP voltage. An external capacitor Cp can be connected to CP to stabilize the voltage, but the gain tracking time is dependent on the capacitance. When HLDN is open (or HIGH), the gain automatically adjusts to follow the post-amplifier detector signal. When HLDN is LOW, the immediately preceding gain is held for an interval determined by the Cp capacitance.

HLDN	Gain tracking
Open or HIGH	Auto tracking
LOW	Gain held fixed

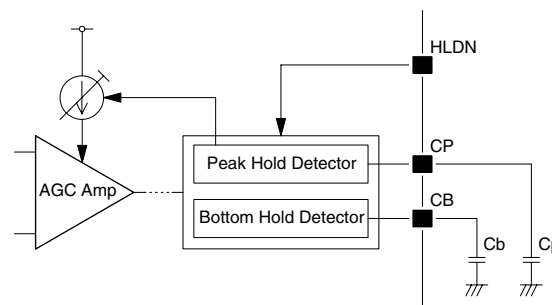

Crystal Filter Circuit

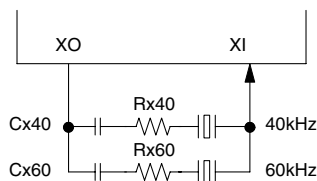

External crystals are used as filters. Multiple frequencies (40kHz and 60kHz) are supported by connecting crystals in parallel. The center frequency and bandwidth of the filters is determined by the crystal characteristics. If the center frequency is lower than the target frequency, Cx40 and Cx60 can be added to change the resonant frequency. And Rx40 and Rx60 can be added to adjust the filter Q factor. Internally, pin XO is linked to pin XI by a phase-inverted signal passed through a capacitor, which cancels the high-frequency components that pass through the crystal parallel capacitances.

Detector Circuit

The amplified signal is full-wave rectified and passed through a lowpass filter detector. The detector output is input to peak hold (pin CP) and bottom hold (pin CB) circuits to form the decoder reference potentials and peak hold potential for AGC control.

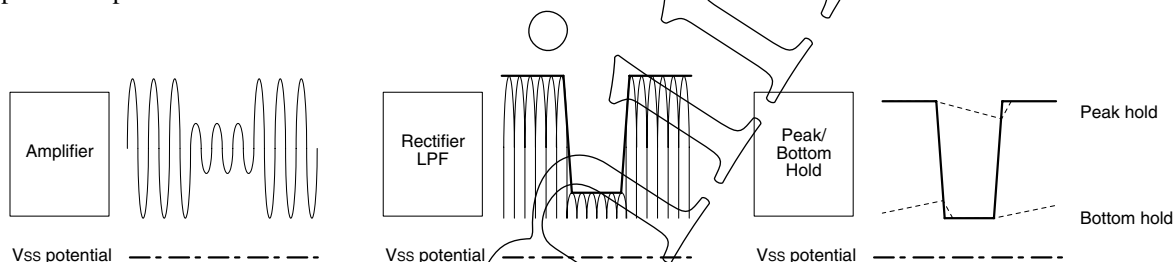

Decoder Circuit

The detector output and peak/bottom hold mid-level potential reference are used to decode the time code signal, which is output on pin OUT. The output is active-LOW, so that the output is LOW when the input amplitude is HIGH.

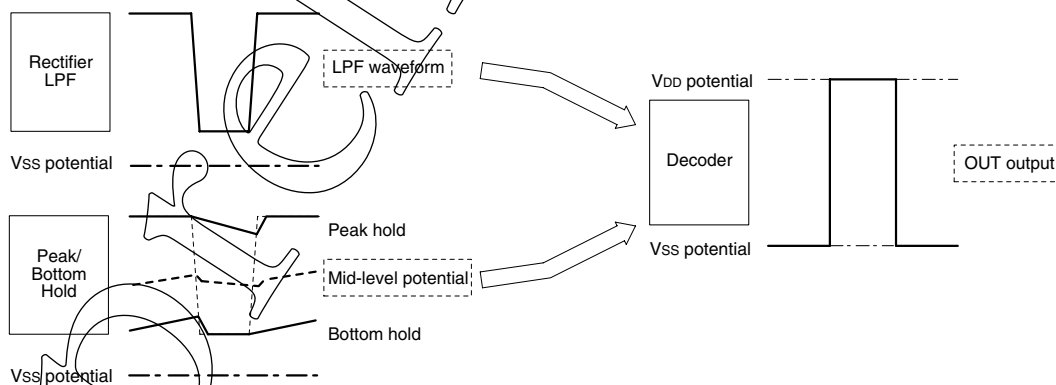

Standby Function

When PON is open (or HIGH), the device is in standby mode and the current consumption is reduced. Receiver operation starts when PON goes LOW.

PON	Mode	OUT
Open (or HIGH)	Standby	HIGH
LOW	Operating	Time code

Preliminary

Please pay your attention to the following points at time of using the products shown in this document.

The products shown in this document (hereinafter "Products") are not intended to be used for the apparatus that exerts harmful influence on human lives due to the defects, failure or malfunction of the Products. Customers are requested to obtain prior written agreement for such use from NIPPON PRECISION CIRCUITS INC. (hereinafter "NPC"). Customers shall be solely responsible for, and indemnify and hold NPC free and harmless from, any and all claims, damages, losses, expenses or lawsuits, due to such use without such agreement. NPC reserves the right to change the specifications of the Products in order to improve the characteristic or reliability thereof. NPC makes no claim or warranty that the contents described in this document dose not infringe any intellectual property right or other similar right owned by third parties. Therefore, NPC shall not be responsible for such problems, even if the use is in accordance with the descriptions provided in this document. Any descriptions including applications, circuits, and the parameters of the Products in this document are for reference to use the Products, and shall not be guaranteed free from defect, inapplicability to the design for the mass-production products without further testing or modification. Customers are requested not to export or re-export, directly or indirectly, the Products to any country or any entity not in compliance with or in violation of the national export administration laws, treaties, orders and regulations. Customers are requested appropriately take steps to obtain required permissions or approvals from appropriate government agencies.

NPC
NIPPON PRECISION CIRCUITS INC.

NIPPON PRECISION CIRCUITS INC.

4-3, Fukuzumi 2-chome, Koto-ku,
Tokyo 135-8430, Japan
Telephone: +81-3-3642-6661
Facsimile: +81-3-3642-6698
<http://www.npc.co.jp/>
Email: sales@npc.co.jp