

**Voltage-Controlled Attenuator Module
100 to 2000 MHz**

G30 / SMG30

V3

Features

- FAST SWITCHING: < 0.2 μ sec, 10 TO 90% (TYP.)
< 1 μ sec, 0 TO 100% (TYP.)
- HIGH DYNAMIC RANGE: 40 dB TO 1000 MHz (TYP.)
- LOW VSWR: 1.4:1 (TYP.)

Description

The G30 attenuator is a discrete hybrid design, which uses thin film manufacturing processes for accurate performance and high reliability.

This design uses three pin diodes to provide a non linear attenuation response across a broadband frequency range. Both TO-8 and Surface Mount packages are hermetically sealed, and MIL-STD-883 environmental screening is available.

Ordering Information

Part Number	Package
G30	TO-8
SMG30	Surface Mount
CG30 **	SMA Connectorized

** The connectorized version is not RoHs compliant.

Product Image



Electrical Specifications: $Z_0 = 50\Omega$, $V_{CC} = +15 V_{DC}$

Parameter	Units	Typical	Guaranteed	
		25°C	0° to 50°C	-54° to +85°C*
Frequency	MHz	5-2200	100-2000	100-2000
Maximum Attenuation Available (min)	100-500 MHz	>50	40	37
	500-1000 MHz	>44	35	32
	1000-2000 MHz	>38	30	27
Insertion Loss ($V_{ctrl} = +15 V$) (max)	100-500 MHz	<2.1	2.8	3.0
	500-1000 MHz	<2.3	3.0	3.2
	1000-2000 MHz	<3.0	3.5	3.8
VSWR (worst case in attenuation range)	0-25 dB Attenuation	1.4:1	2.0:1	2.0:1
	>25 dB Attenuation	<1.7:1	2.2:1	2.2:1
Flatness Over Frequency (max) (Attenuation = min to 15 dB, 100-1000 MHz)	100-1000 MHz	± 0.5	± 1.0	± 1.0
	1000-2000 MHz	± 1.0	± 1.5	± 1.7
Switching Speed (max.)	10% - 90%	<0.2	0.4	0.6
	0% - 100%	<1	2	3
Bias Voltage	Volts	+15	+15	+15
Bias Current (max)	mA	7	10	12
Control Voltage	Volts	0 to +15	0 to +15	0 to +15
Control Current (max)	mA	7	10	10

* Over temperature performance limits for part number CG30, guaranteed from 0°C to +50°C only.

M/A-COM Inc. and its affiliates reserve the right to make changes to the product(s) or information contained herein without notice. M/A-COM makes no warranty, representation or guarantee regarding the suitability of its products for any particular purpose, nor does M/A-COM assume any liability

• **North America** Tel: 800.366.2266 / Fax: 978.366.2266
 • **Europe** Tel: 44.1908.574.200 / Fax: 44.1908.574.300
 • **Asia/Pacific** Tel: 81.44.844.8296 / Fax: 81.44.844.8298

**Voltage-Controlled Attenuator Module
100 to 2000 MHz**

G30 / SMG30

V3

Typical Performance Curves at +25°C

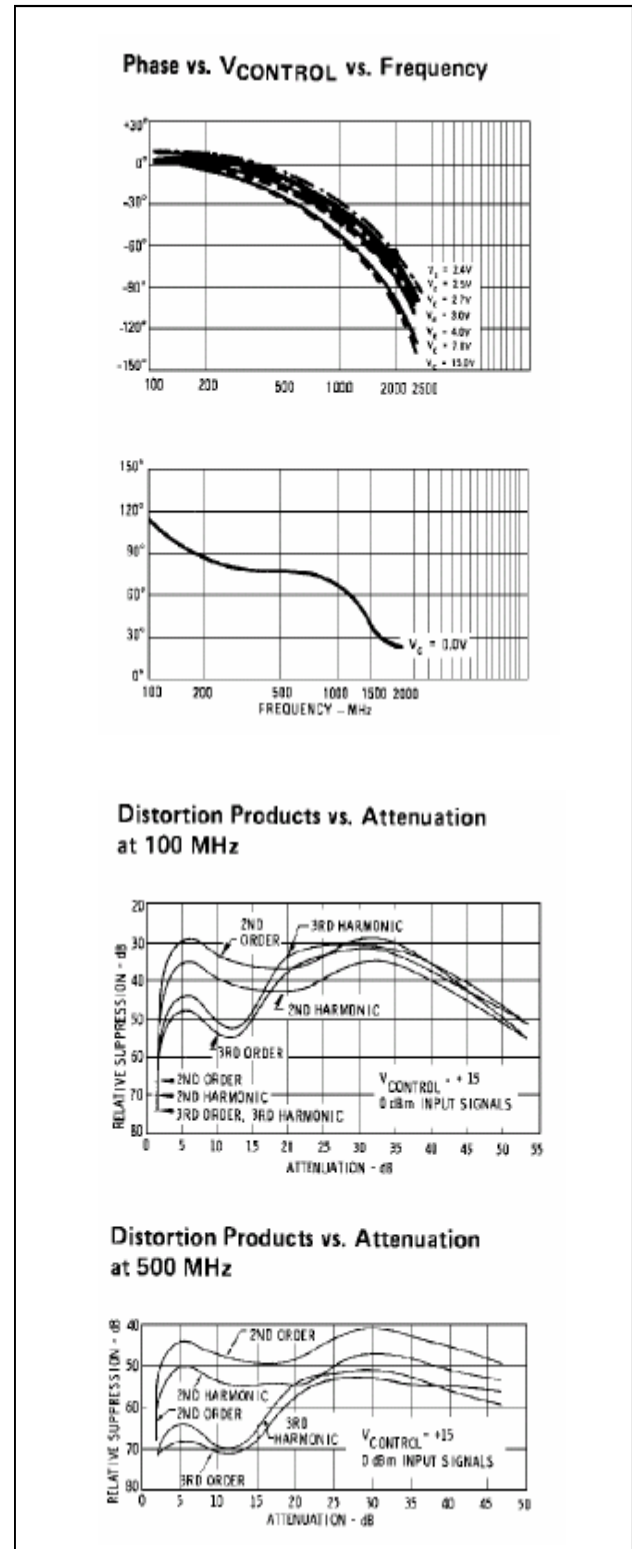
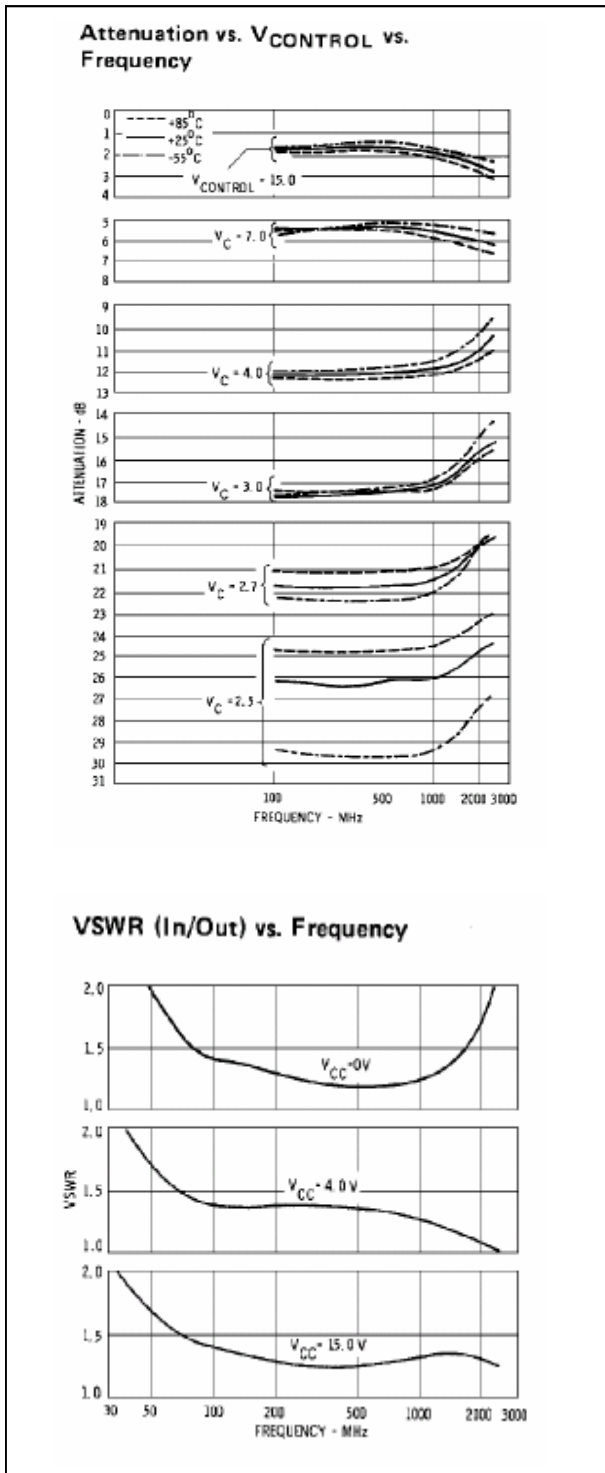

**Voltage-Controlled Attenuator Module
100 to 2000 MHz**

G30 / SMG30

V3

Typical Performance Curves at +25°C

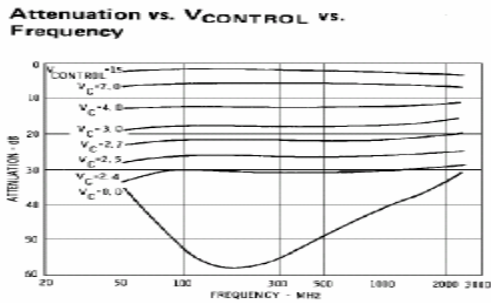
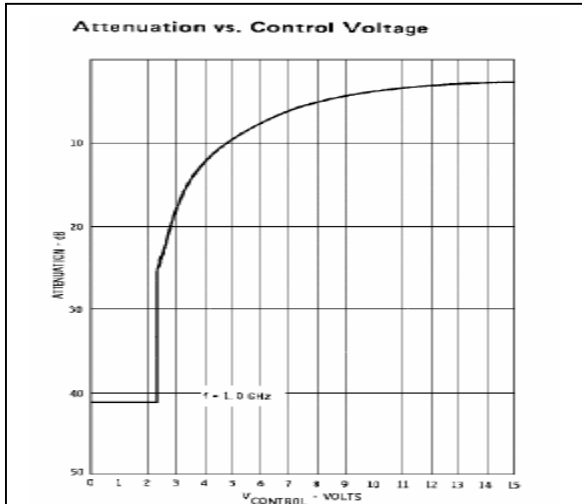

Absolute Maximum Ratings

Parameter	Absolute Maximum
Storage Temperature	-62°C to +125°C
Maximum Case Temperature	125°C
Maximum DC Voltage	+18 V
Maximum DC Bias Voltage	+20 V
Maximum Short Term RF Input power (1 minute max.)	200 mW
Maximum Peak Power (3 μ sec max.)	1 W
"S" Series Burn-In Temperature (case)	+125°C

Outline Drawing: TO-8 *

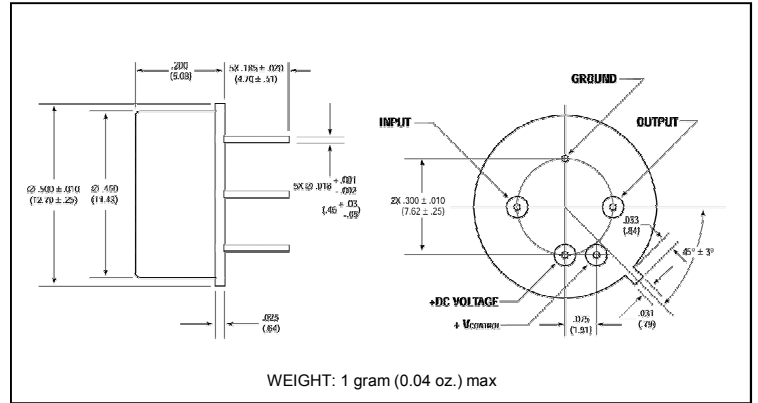

WEIGHT: 1 gram (0.04 oz.) max

Outline Drawing: Surface Mount *

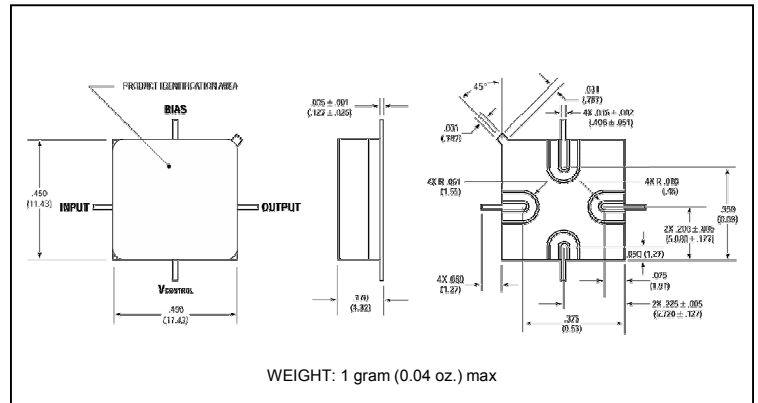

WEIGHT: 1 gram (0.04 oz.) max

Outline Drawing: SMA Connectorized *

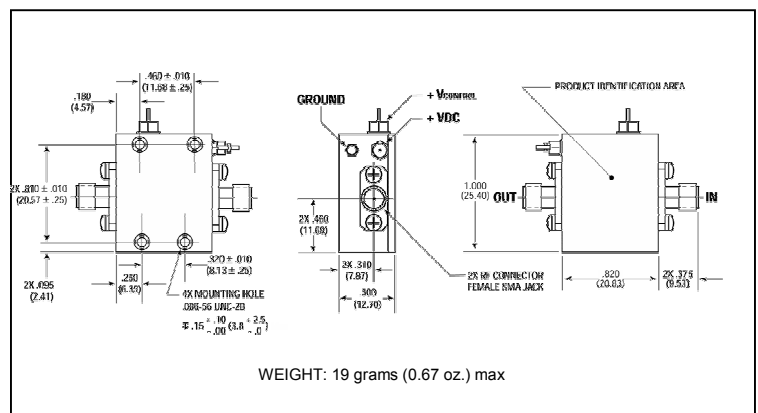

WEIGHT: 19 grams (0.67 oz.) max

* Dimensions are inches (millimeters) ±0.015 (0.38) unless otherwise specified.