

5.8-17GHz Low Noise Amplifier

GaAs Monolithic Microwave IC in SMD leadless package

Description

The CHA3666-QAG is a two-stage self-biased wide band monolithic low noise amplifier.

The circuit is manufactured with a standard pHEMT process: 0.25µm gate length, via holes through the substrate, air bridges and electron beam gate lithography.

It is supplied in lead-free package.

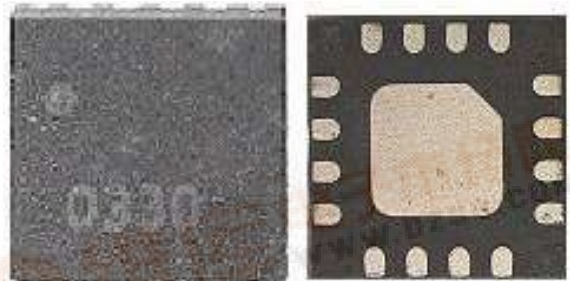

Gain & NF @Config; P1=N2=grounded

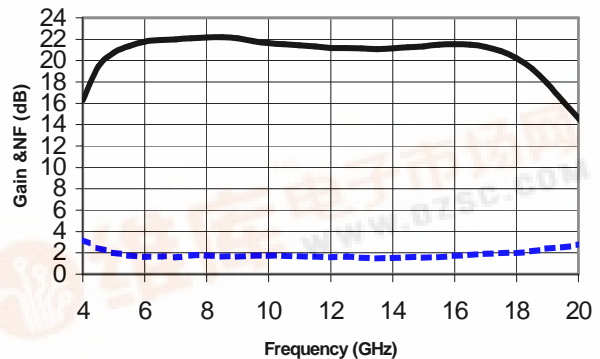

Main Features

- Broadband performance 6-17GHz
- 1.8dB noise figure
- 26dBm 3rd order intercept point
- 16dBm power at 1dB compression
- 21dB gain
- Low DC power consumption
- 16L-QFN3X3 SMD package

Main Characteristics

Temp = +25°C, Vd1=Vd2= +4V, P1& N2=GND

Symbol	Parameter	Min	Typ	Max	Unit
NF	Noise figure		1.8	2	dB
G	Gain	19	21		dB
IP3	3rd order intercept point		26		dBm

ESD Protections: Electrostatic discharge sensitive device observe handling precautions!



Electrical Characteristics

Temp = +25°C, P1, N2 = GND (1)

Symbol	Parameter	Min	Typ	Max	Unit
Fop	Operating frequency range	5.8		17	GHz
G	Gain (2)	19	21		dB
ΔG	Gain flatness		± 0.5		dB
NF	Noise figure (2)		1.8	2	dB
IS11I	Input return loss (2)		2.5:1	2.7:1	
IS22I	Output return loss (2)		2.0:1	2.2:1	
IP3	3rd order intercept point		26		dBm
P1dB	Output power at 1dB gain comp (2)(3).	15	16		dBm
Vd1, 2	Drain bias voltage		4		V
Id	Drain bias current	60	80	100	mA

(1) The other leads are not connected.

(2) These values are representative of on board measurements as defined on the drawing 96272 (see below).

(3) P1dB can be increased (+0.5dBm) when P1 & P2 are connected to ground and the other leads non-connected. In this case Id is typically of 85mA.

Absolute Maximum Ratings (1)

Temp = +25°C

Symbol	Parameter	Values	Unit
Vd	Drain bias voltage	4.5	V
Pin	RF input power	10	dBm
Top	Operating temperature range	-40 to +85	°C
Tj	Junction temperature	175	°C
Tstg	Storage temperature range	-55 to +125	°C

(1) Operation of this device above any one of these parameters may cause permanent damage.

Thermal data based on board defined page 11

DEVICE THERMAL SPECIFICATION : CHA3666-QAG P1N2=GND		
Max. junction temperature (Tj max)	:	153 °C
Max. continuous dissipated power @ Tcase= 85 °C	:	0.32 W
=> Pdiss derating above Tcase= 85 °C	:	5 mW/°C
Device thermal resistance (Rth)	:	214 °C/W
Min. package back side operating temperature*	:	-40 °C
Max. package back side operating temperature*	:	85 °C
Min. storage temperature	:	-55 °C
Max. storage temperature	:	125 °C

*Tcase=Package back side temperature measured under the die-attach-pad.

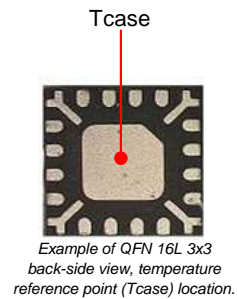
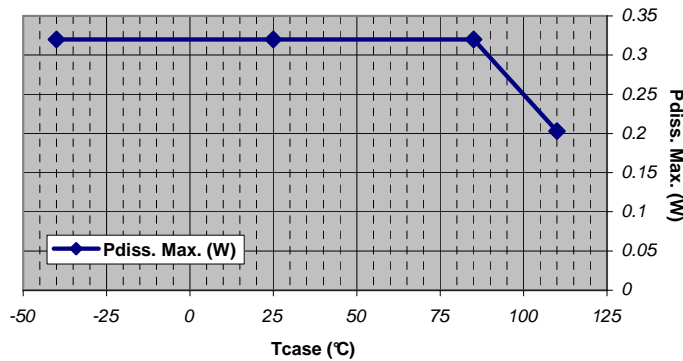

DEVICE THERMAL SPECIFICATION : CHA3666-QAG P1P2=GND		
Max. junction temperature (Tj max)	:	153 °C
Max. continuous dissipated power @ Tcase= 85 °C	:	0.34 W
=> Pdiss derating above Tcase= 85 °C	:	5 mW/°C
Device thermal resistance (Rth)	:	201 °C/W
Min. package back side operating temperature*	:	-40 °C
Max. package back side operating temperature*	:	85 °C
Min. storage temperature	:	-55 °C
Max. storage temperature	:	125 °C

*Tcase=Package back side temperature measured under the die-attach-pad.

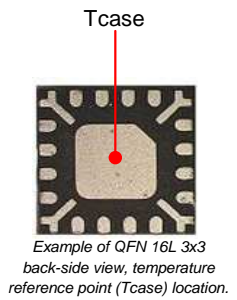
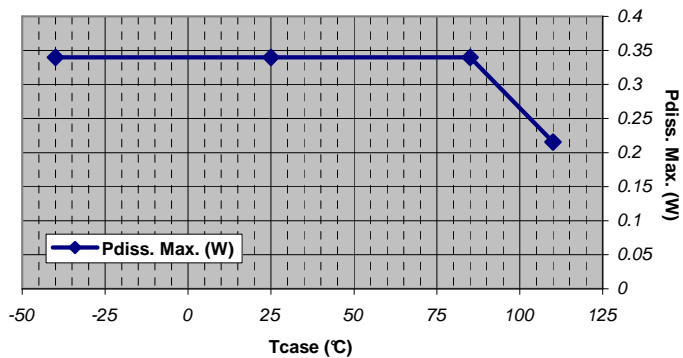

Typical Package Sij parameters for low current configuration

Temp = +25°C, Vd1=Vd2= +4V, typical Id=80mA P1, N2 = GND

F(GHz)	dBS11	PhS11(°)	dBS21	PhS21(°)	dBS12	PhS12(°)	dBS22	PhS22(°)	NF(dB)
1,00	-0,09	-37,85	-52,18	137,30	-66,34	-86,13	-0,24	-36,27	
1,50	-0,17	-57,58	-60,02	-45,40	-68,26	-149,70	-0,21	-55,53	
2,00	-0,27	-78,58	-29,12	-11,07	-62,73	-158,40	-0,40	-76,22	
2,50	-0,47	-102,50	-11,73	-37,70	-60,61	141,90	-1,09	-99,08	
3,00	-0,91	-131,30	1,07	-86,70	-67,97	148,20	-2,87	-120,80	
3,50	-1,99	-170,20	10,07	-144,40	-64,90	-21,46	-5,19	-134,50	
4,00	-4,95	131,20	16,26	154,50	-58,71	-137,00	-7,01	-141,30	2,91
4,50	-9,47	46,82	19,44	94,84	-47,18	168,40	-8,02	-147,50	2,45
5,00	-9,90	-29,48	20,76	45,24	-45,08	132,60	-8,95	-155,40	1,97
5,50	-9,48	-70,17	21,36	3,43	-42,32	101,00	-9,67	-161,70	1,67
6,00	-9,12	-92,50	21,76	-32,80	-41,24	78,57	-10,26	-168,50	1,54
6,50	-8,87	-107,10	21,92	-65,87	-39,31	54,54	-10,75	-178,10	1,59
7,00	-8,39	-120,20	22,00	-95,39	-39,37	32,14	-11,22	170,60	1,52
7,50	-8,08	-134,00	22,08	-123,10	-38,59	10,27	-11,97	155,50	1,68
8,00	-8,05	-146,70	22,17	-149,60	-38,58	-11,10	-13,37	136,20	1,72
8,50	-7,93	-159,40	22,18	-175,50	-37,62	-30,90	-15,43	115,40	1,63
9,00	-7,94	-173,80	22,10	159,30	-37,78	-39,64	-18,09	89,58	1,62
9,50	-8,32	172,20	21,82	135,70	-36,70	-65,10	-20,88	56,05	1,67
10,00	-9,01	157,70	21,64	113,60	-36,83	-81,53	-22,71	16,48	1,71
10,50	-9,80	142,20	21,52	91,87	-36,41	-101,90	-22,45	-26,02	1,71
11,00	-10,55	125,50	21,42	70,57	-35,93	-117,80	-21,60	-59,75	1,66
11,50	-11,13	109,40	21,31	49,41	-35,96	-137,50	-20,83	-82,56	1,62
12,00	-11,82	91,93	21,16	29,06	-35,66	-154,20	-20,36	-98,06	1,58
12,50	-12,41	76,20	21,17	8,99	-35,34	-173,60	-20,00	-113,80	1,63
13,00	-12,37	59,41	21,15	-11,91	-35,74	168,30	-20,92	-130,10	1,55
13,50	-12,07	40,87	21,08	-32,15	-35,37	154,30	-23,41	-136,20	1,50
14,00	-12,07	22,74	21,14	-52,19	-33,72	140,00	-22,32	-137,50	1,54
14,50	-11,24	7,92	21,24	-72,86	-35,92	118,20	-22,12	-146,20	1,57
15,00	-10,18	-9,73	21,33	-93,85	-36,96	85,55	-22,14	-153,80	1,54
15,50	-9,31	-27,72	21,51	-116,50	-37,19	67,53	-20,95	-174,90	1,58
16,00	-8,48	-46,24	21,53	-139,20	-37,70	45,96	-19,59	159,80	1,70
16,50	-7,67	-66,34	21,48	-163,20	-38,82	25,63	-17,54	124,50	1,80
17,00	-7,21	-88,27	21,27	171,60	-39,99	-5,00	-15,22	88,77	1,95
17,50	-6,95	-111,10	20,89	146,10	-47,86	-18,70	-13,42	58,24	1,98
18,00	-6,97	-137,00	20,22	120,00	-71,77	-44,50	-10,69	30,88	1,97
18,50	-7,48	-167,10	19,22	93,46	-49,03	133,30	-8,82	2,77	2,16
19,00	-8,44	162,80	17,86	68,78	-43,68	87,71	-7,83	-22,41	2,35
19,50	-9,50	129,30	16,20	45,38	-40,71	67,86	-6,87	-43,91	2,48
20,00	-10,39	95,35	14,62	25,08	-40,21	48,11	-6,46	-61,92	2,67

Refer to the “definition of the Sij reference planes” section below.

Typical Package Sij parameters for high current configuration

Temp = +25°C, Vd1=Vd2= +4V, typical Id= 86mA P1, P2 = GND

F(GHz)	dBS11	PhS11(°)	dBS21	PhS21(°)	dBS12	PhS12(°)	dBS22	PhS22(°)	NF(dB)
1,00	-0,10	-38,12	-51,07	154,70	-58,77	-115,10	-0,23	-36,50	
1,50	-0,17	-57,85	-59,34	-26,09	-66,35	-81,29	-0,20	-55,71	
2,00	-0,29	-78,80	-28,95	-9,44	-66,30	149,00	-0,40	-76,31	
2,50	-0,50	-102,50	-11,71	-38,04	-61,37	124,50	-1,09	-98,95	
3,00	-0,94	-131,20	1,13	-86,50	-65,28	116,80	-2,81	-120,40	
3,50	-2,07	-170,20	10,20	-144,40	-74,13	37,65	-5,08	-133,70	
4,00	-5,28	129,80	16,42	153,80	-56,80	-156,90	-6,82	-140,20	2,93
4,50	-10,01	40,92	19,50	93,70	-48,32	168,00	-7,74	-146,10	2,43
5,00	-9,91	-35,58	20,73	44,18	-43,98	131,00	-8,53	-153,80	2,00
5,50	-9,34	-74,07	21,28	2,92	-42,51	102,20	-9,24	-160,00	1,74
6,00	-8,94	-94,94	21,67	-32,98	-41,13	73,15	-9,76	-166,30	1,59
6,50	-8,62	-108,60	21,83	-65,73	-39,94	52,60	-10,20	-175,20	1,63
7,00	-8,15	-121,40	21,91	-95,13	-39,14	32,34	-10,61	173,80	1,53
7,50	-7,87	-135,10	22,00	-122,50	-38,78	7,76	-11,36	159,80	1,69
8,00	-7,84	-147,90	22,11	-148,90	-38,43	-11,09	-12,74	142,20	1,71
8,50	-7,82	-160,50	22,15	-174,70	-36,93	-29,03	-14,93	124,00	1,64
9,00	-7,84	-174,60	22,08	160,00	-37,08	-43,41	-18,00	100,70	1,61
9,50	-8,29	170,70	21,79	136,40	-37,31	-63,49	-21,92	69,39	1,68
10,00	-9,07	157,10	21,62	114,40	-36,75	-79,53	-25,37	20,68	1,70
10,50	-10,00	141,60	21,50	92,72	-36,09	-101,30	-24,20	-37,52	1,73
11,00	-10,82	126,20	21,40	71,49	-36,10	-118,70	-21,65	-72,89	1,66
11,50	-11,56	110,10	21,30	50,42	-35,94	-136,90	-20,10	-94,73	1,64
12,00	-12,24	93,43	21,15	29,96	-35,35	-155,90	-19,20	-108,10	1,58
12,50	-12,94	77,04	21,12	10,07	-35,62	-176,50	-18,36	-121,60	1,67
13,00	-13,14	61,01	21,16	-10,38	-35,79	167,70	-18,41	-136,50	1,57
13,50	-12,77	40,95	21,10	-30,88	-35,38	152,40	-20,21	-144,30	1,51
14,00	-12,62	22,25	21,14	-50,80	-34,81	131,40	-20,02	-143,90	1,56
14,50	-11,89	5,31	21,24	-71,12	-35,50	110,30	-19,31	-145,20	1,59
15,00	-10,98	-11,61	21,36	-91,89	-35,37	88,68	-18,30	-151,20	1,59
15,50	-9,93	-30,60	21,60	-114,20	-36,49	70,74	-17,36	-170,10	1,62
16,00	-8,94	-49,93	21,70	-137,00	-36,11	42,49	-16,39	174,50	1,75
16,50	-8,02	-70,22	21,75	-161,30	-38,73	31,56	-14,82	145,80	1,87
17,00	-7,47	-90,97	21,54	172,90	-40,94	-11,86	-13,42	110,00	2,00
17,50	-6,89	-114,60	21,12	147,30	-44,21	-54,62	-12,54	75,31	2,03
18,00	-6,84	-139,40	20,45	121,30	-52,00	-103,90	-10,83	42,27	2,06
18,50	-7,02	-167,10	19,55	94,64	-49,81	161,20	-9,00	12,10	2,24
19,00	-7,77	163,80	18,18	68,72	-43,10	105,40	-7,54	-17,98	2,47
19,50	-8,85	132,90	16,46	45,53	-40,09	74,77	-6,94	-42,60	2,64
20,00	-9,90	100,10	14,78	24,54	-39,56	45,06	-6,12	-62,32	2,84

Refer to the "definition of the Sij reference planes" section below.

Typical Measured Performance

Temp = +25°C, Vd1=Vd2=4V

Measurements in the package access planes, using the proposed land pattern & board 96272

P1=N2 = GND (Id=80mA)

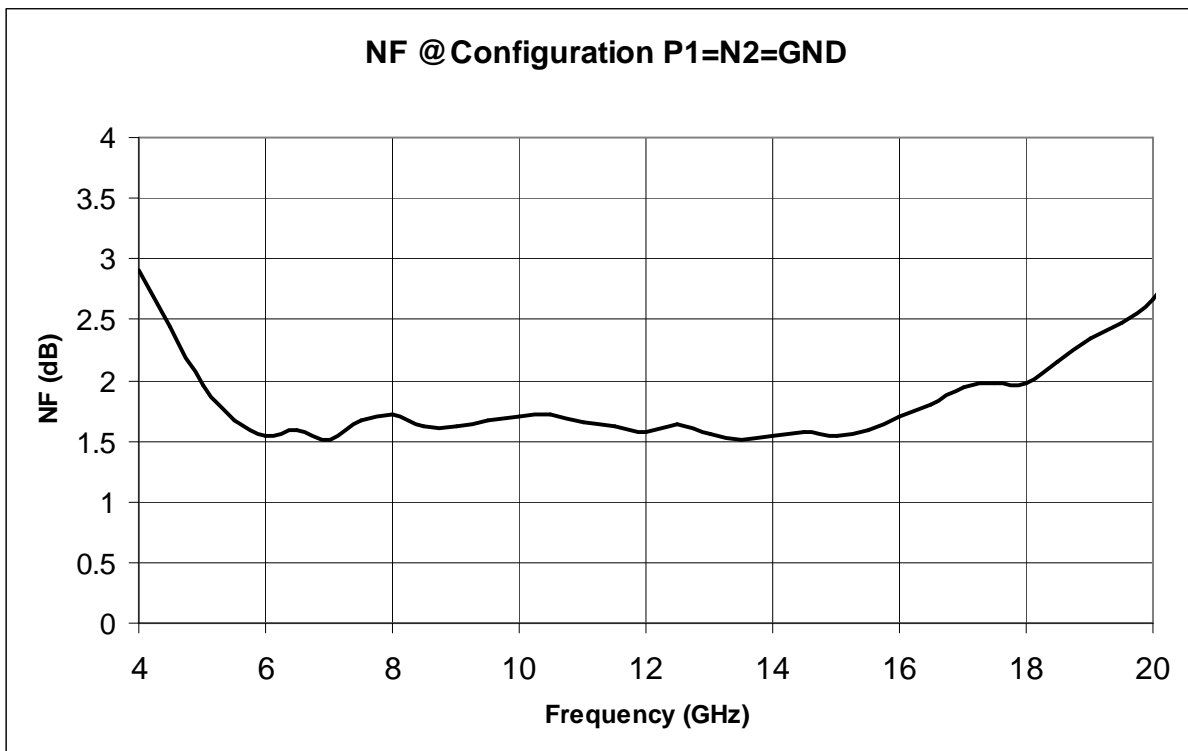
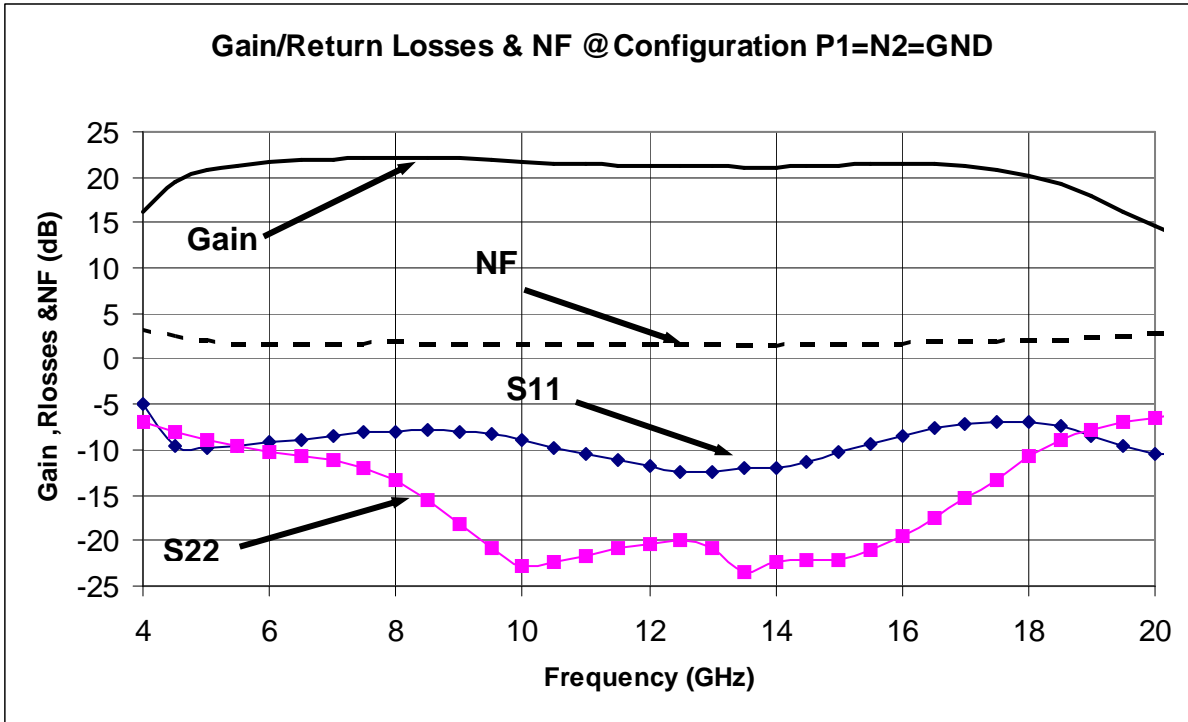

Output power at 1dB compression versus frequency

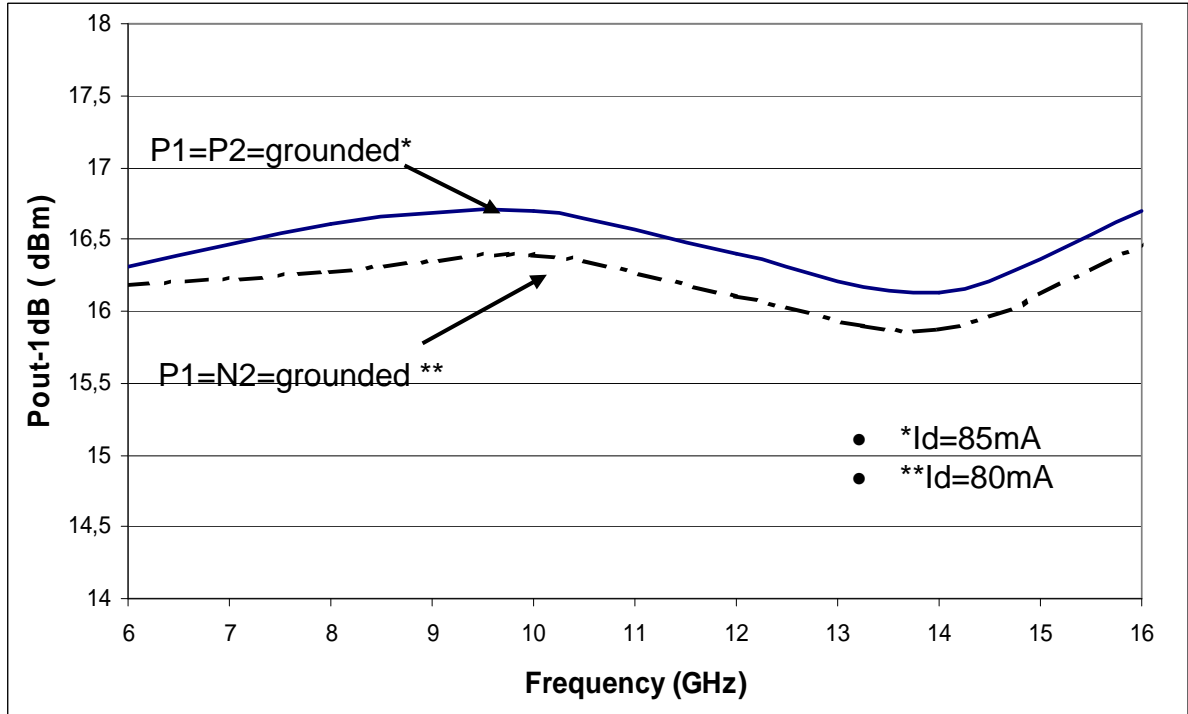

Output power at 1dB compression versus frequency configuration P1=N2=GND (Variation of Vd)

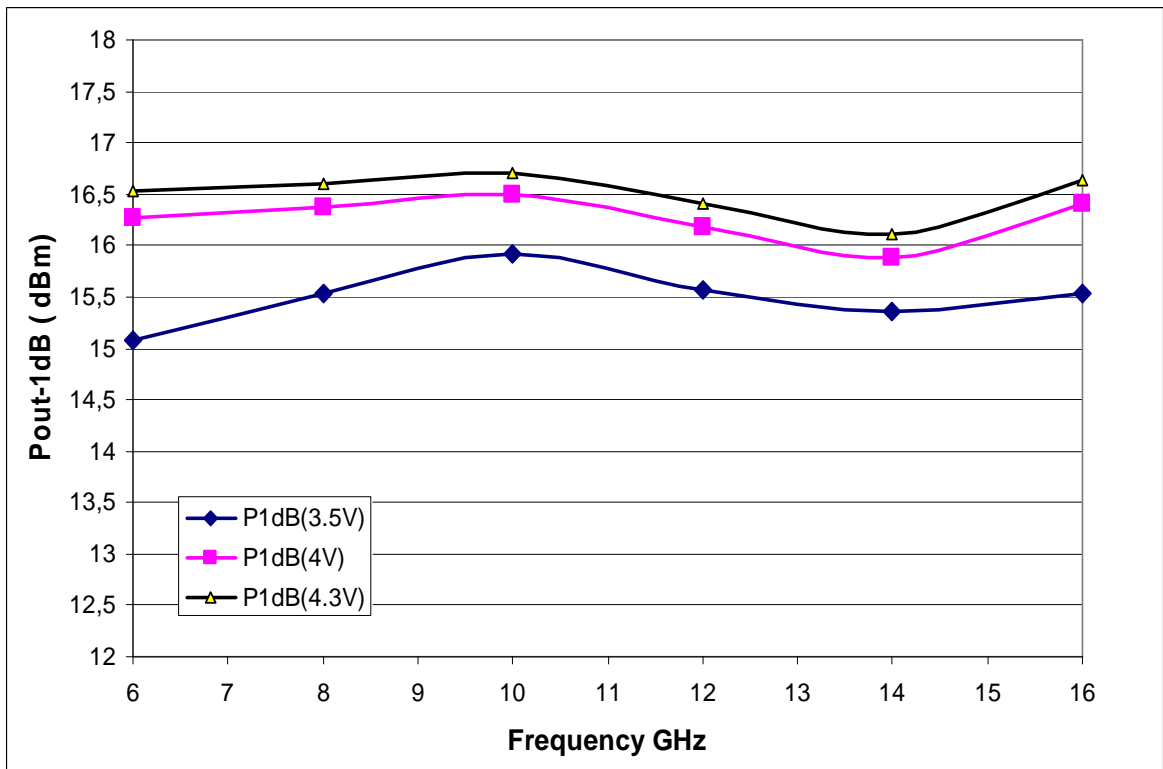

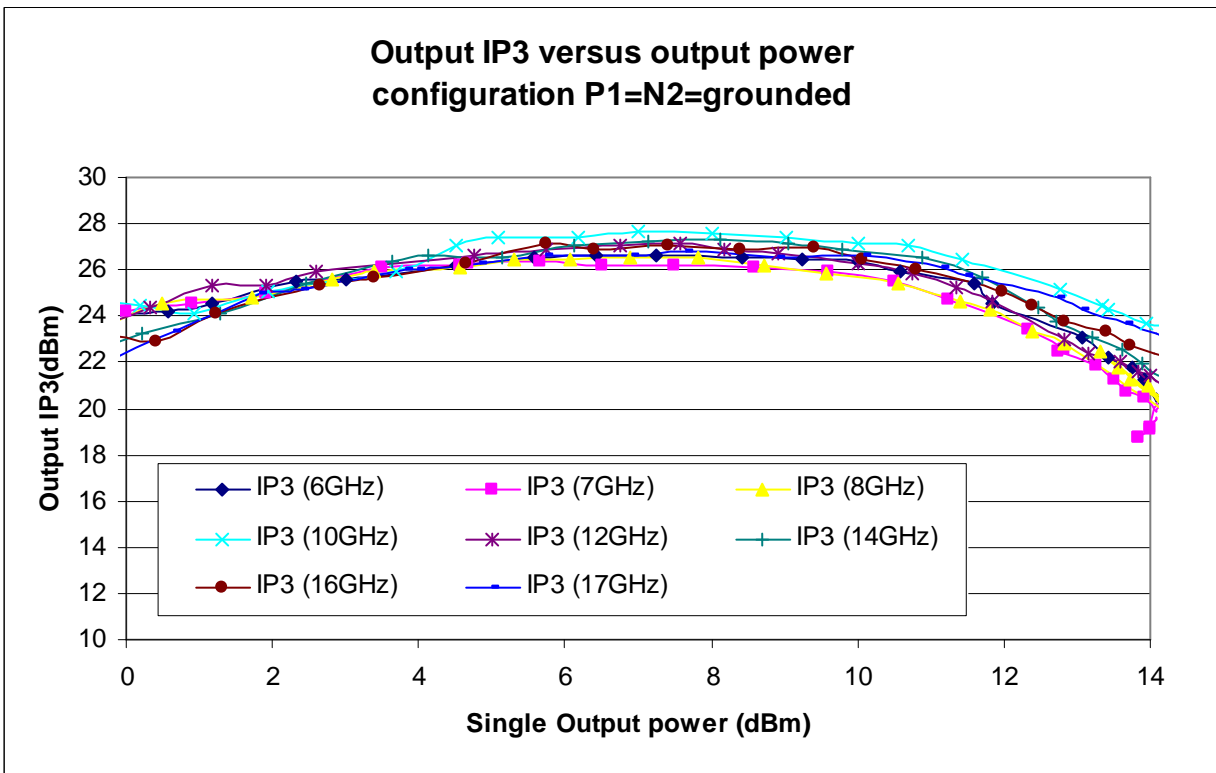
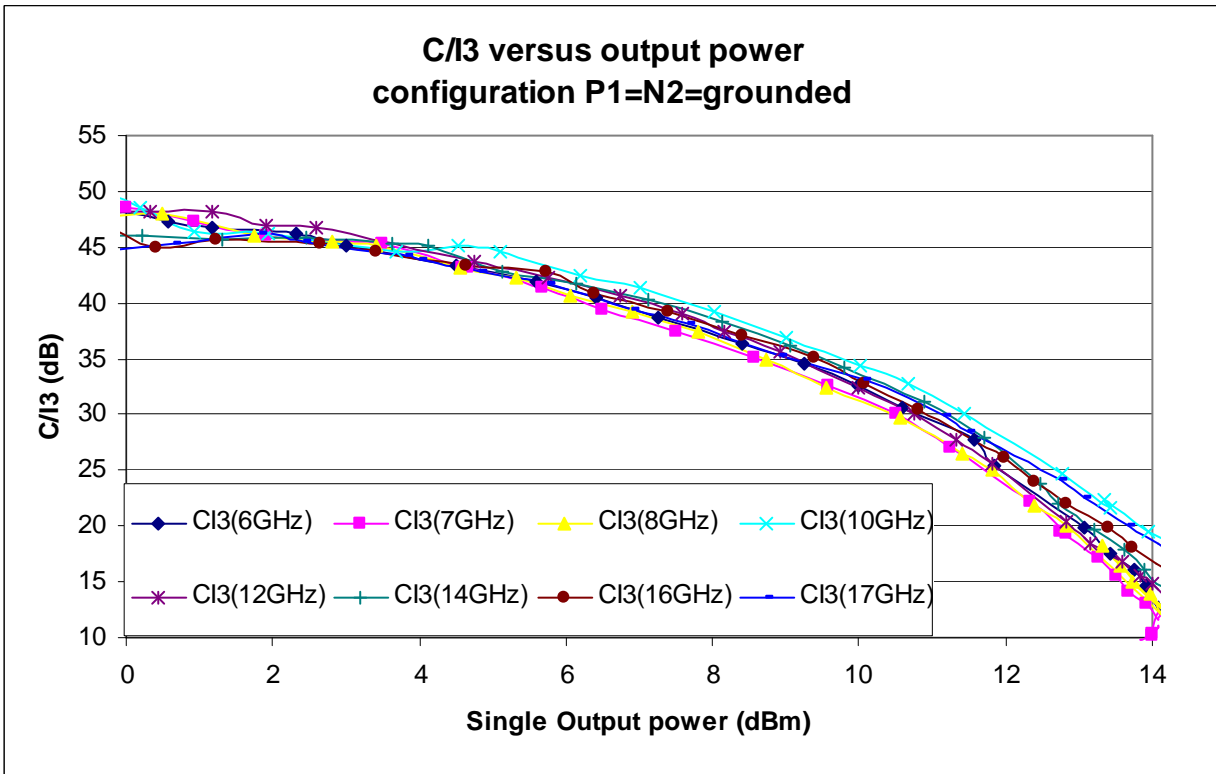

Package outline:

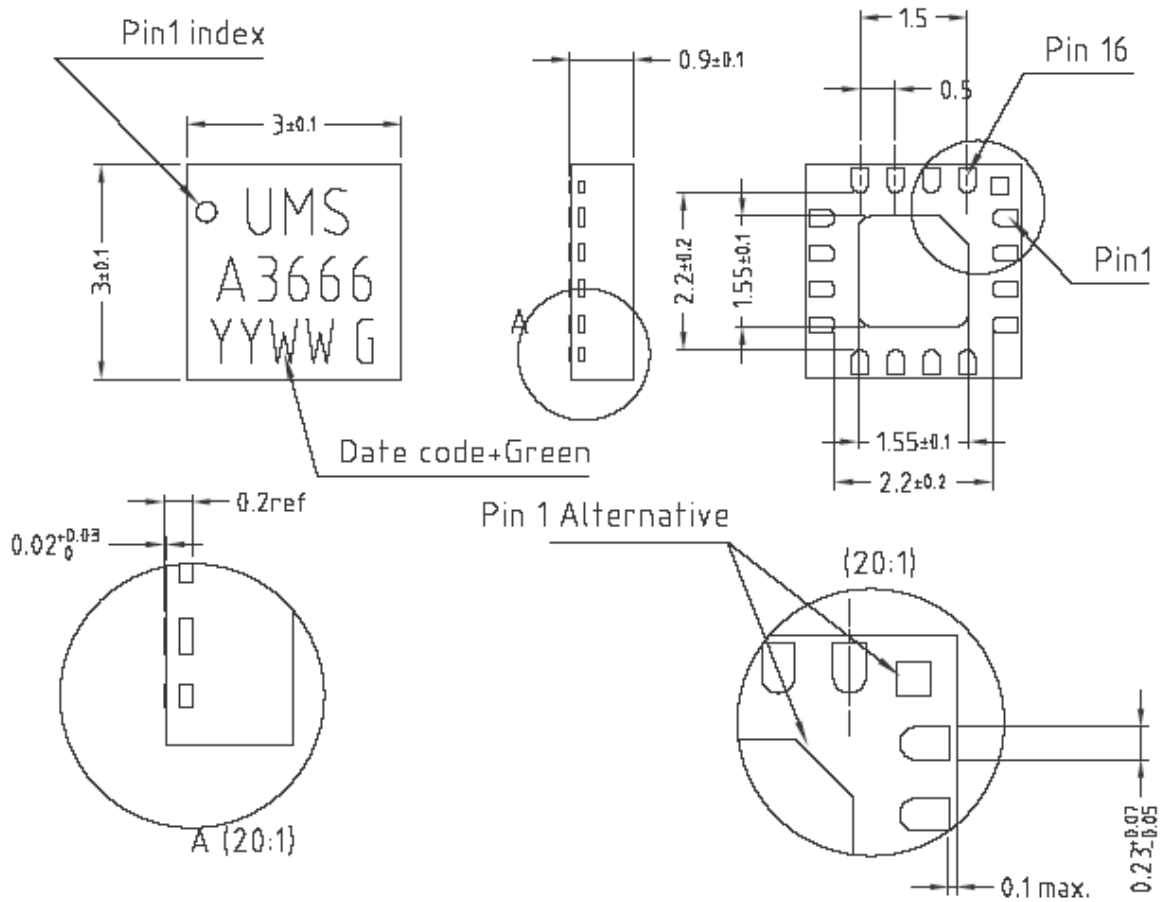

Matt tin, Lead free (Green)

Units : mm

From the standard : JEDEC MO-220

1- NC	9- Gnd
2- Gnd	10- RF Out
3- RF In	11- Gnd
4- Gnd	12- Nc
5- P1	13- Nc
6- NC	14- VD2
7- P2	15- Gnd
8- N2	16- VD1

Definition of the Sij reference planes

The reference planes are defined from the footprint of the recommended characterization board shown below under the number 96272.

The reference is the symmetrical axis of the package. The input and output reference planes are located at 2.65mm offset (input wise and output wise respectively) from this axis. Then, the given Sij incorporates this land pattern.

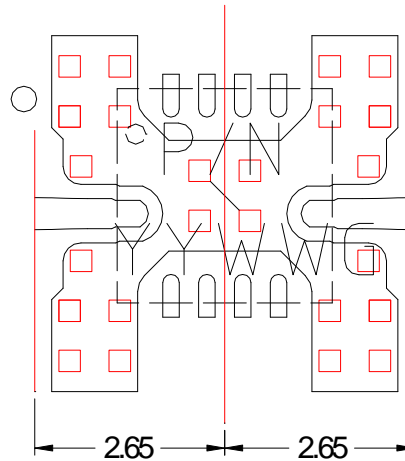

SMD mounting procedure

The SMD leadless package has been designed for high volume surface mount PCB assembly process. The dimensions and footprint required for the PCB (motherboard) are given in the drawings above.

For the mounting process standard techniques involving solder paste and a suitable reflow process can be used. For further details, see application note AN0017.

Proposed Assembly board "96272" for the 16L-QFN3x3 products characterization.

- Compatible with the proposed footprint.
- Based on typically Ro4003 / 8mils or equivalent.
- Using a microstrip to coplanar transition to access the package.
- Recommended for the implementation of this product on a module board.
- Capacitors: $10\text{nF} \pm 10\%$.

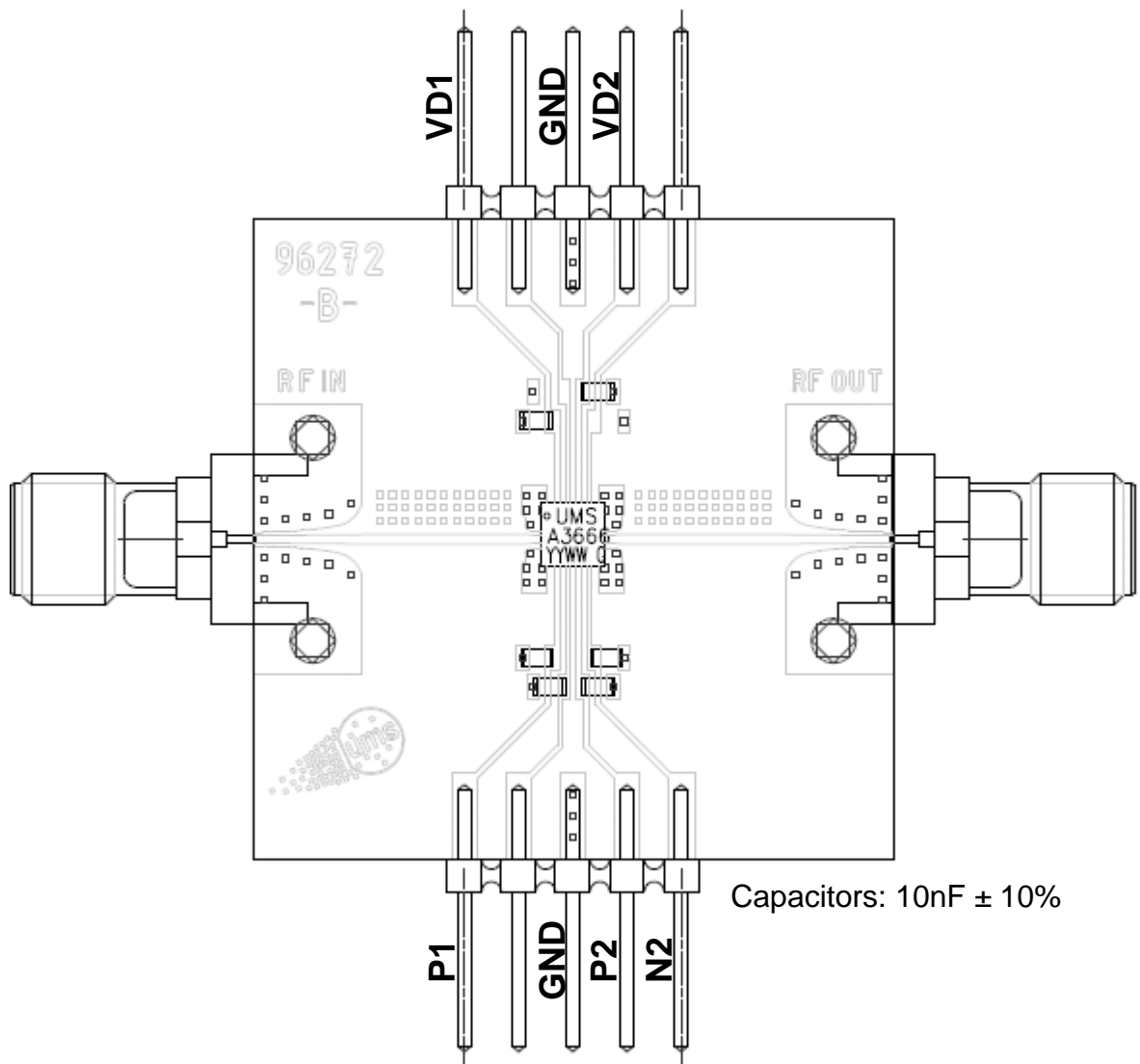

Package Biasing options

This chip is self-biased, and flexibility is provided by the access to number of leads. The internal DC electrical schematic is given in order to use these leads in a safe way. All values are given in Ohms.

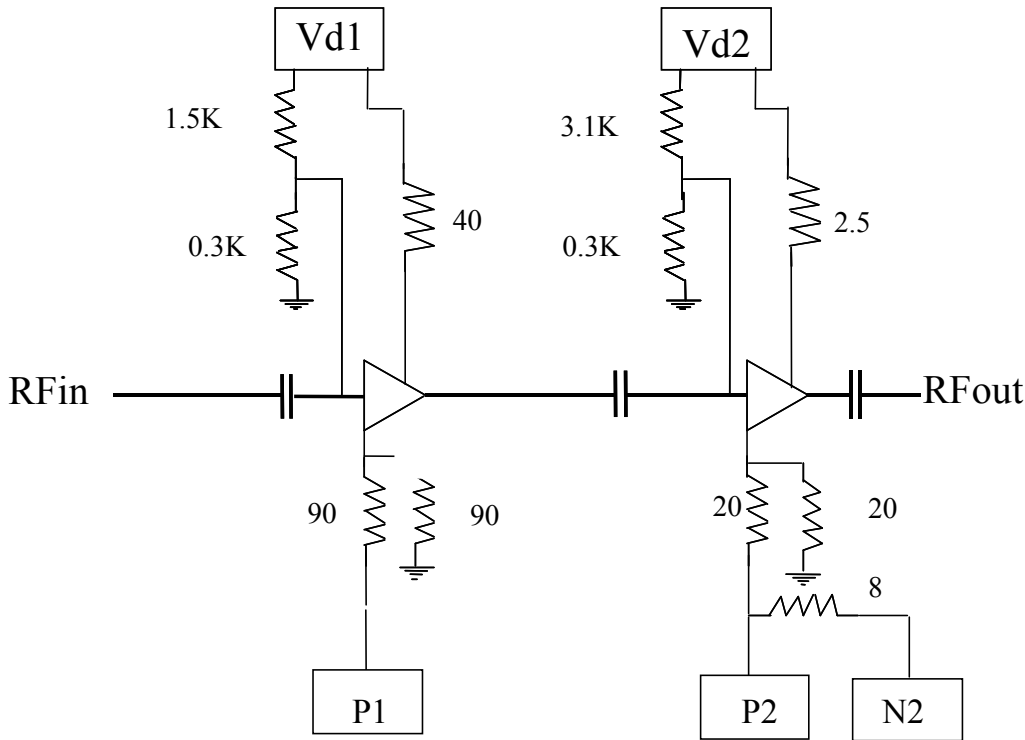

Two standard biasing:

Low Noise and low consumption:

Vd1=Vd2 = 4V and P1, N2 grounded.
P2 lead non connected (NC).
I_{dd} = 80mA & P_{out-1dB} = 16dBm Typical.

Low Noise and higher output power

Vd1=Vd2 = 4V and P1, P2 grounded.
N2 lead non connected (NC).
I_{dd} = 85mA & P_{out-1dB} = 16.5dBm Typical.

Ordering Information

QFN 3x3 RoHS compliant package:

CHA3666-QAG/XY

Stick: XY = 20 Tape & reel: XY = 21

Information furnished is believed to be accurate and reliable. However **United Monolithic Semiconductors S.A.S.** assumes no responsibility for the consequences of use of such information nor for any infringement of patents or other rights of third parties which may result from its use. No license is granted by implication or otherwise under any patent or patent rights of **United Monolithic Semiconductors S.A.S.**. Specifications mentioned in this publication are subject to change without notice. This publication supersedes and replaces all information previously supplied. **United Monolithic Semiconductors S.A.S.** products are not authorised for use as critical components in life support devices or systems without express written approval from **United Monolithic Semiconductors S.A.S.**