

## 7-16GHz Medium Power Amplifier

### GaAs Monolithic Microwave IC

*preliminary*

#### Description

The CHA5051 is a high gain three-stage monolithic medium power amplifier. It is designed for a wide range of applications, from military to commercial communication systems. The backside of the chip is both RF and DC grounds. This helps to simplify the assembly process.

The circuit is manufactured with a pHEMT process, 0.15 $\mu$ m gate length, via holes through the substrate. It is available in chip form

#### Main Features

- Broadband performance 7-16GHz
- 25dB gain & 3dB noise figure
- RF ports ESD protected (see page 12)
- 25dBm output power @ 1dB compression
- DC power consumption, 310mA @ 4.5V
- Chip size 2.41 x 1.5 x 0.10mm

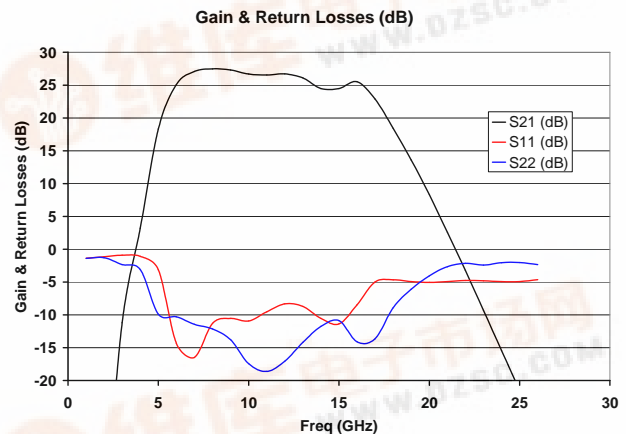
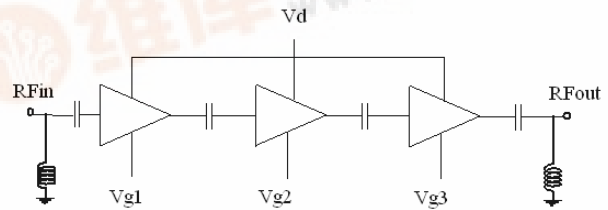

Typical on wafer measurement

#### Main Characteristics

Tamb.=25°C, Vd=4.5V

Symbol	Parameter	Min	Typ	Max	Unit
Fop	Operating frequency range	7		16	GHz
G	Small signal gain		25		dB
NF	Noise figure		3		dB
P1dB	Output power at 1dB gain compression		25		dBm
Id	Bias current		310		mA

ESD Protection: Electrostatic discharge sensitive device. Observe handling precautions!



*preliminary***Electrical Characteristics**

Tamb.=25°C, Vd=4.5V Id=310mA

Symbol	Parameter	Min	Typ	Max	Unit
Fop	Operating frequency range	7		16	GHz
G	Small signal gain		25		dB
P1dB	Pulsed output power at 1dB compression		25		dBm
P03	Output power at 3dB gain compression		26		dBm
NF	Noise Figure		3		dB
VSWRin	Input VSWR		2.5:1		
VSWRout	Output VSWR		2:1		
IP3	Output IP3 from 7 to 13GHz from 14 to 16GHz		33 29		dBm
Vd	DC voltage		4.5		V
Id	Bias current		310		mA

These values are representative for on-wafer measurements that are made without bonding wires at the RF ports.

**Absolute Maximum Ratings**

Tamb. = 25°C (1)

Symbol	Parameter	Values	Unit
Vd	Maximum Drain bias voltage	+5	V
Id	Drain bias current with Vd=4.5V	390	mA
Vg	Gate bias voltage	-2 to +0.4	V
Pin	Maximum input power overdrive (2)	+10	dBm
Tch	Maximum channel temperature	+175	°C
Ta	Operating temperature range	-40 to +85	°C
Tstg	Storage temperature range	-55 to +125	°C

(1) Operation of this device above anyone of these parameters may cause permanent damage.

(2) Duration < 1s.

## Typical Measured Performance

On wafer measurement (without bonding wires at the RF ports)  
Tamb.=+25°C, Vd=+4.5V Id=310mA

*preliminary*

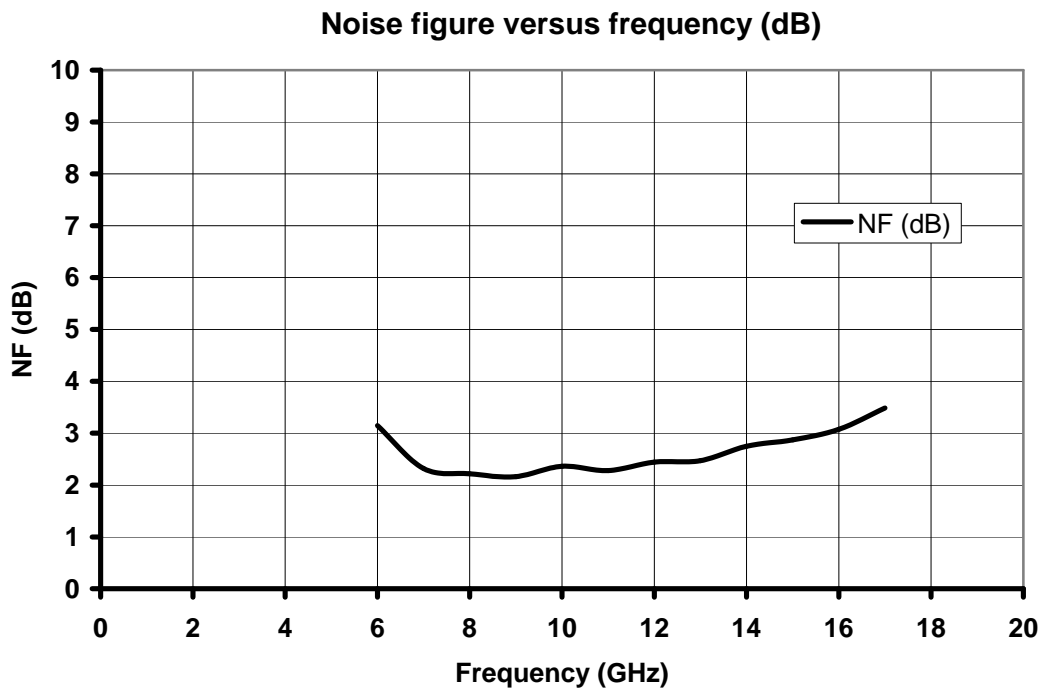
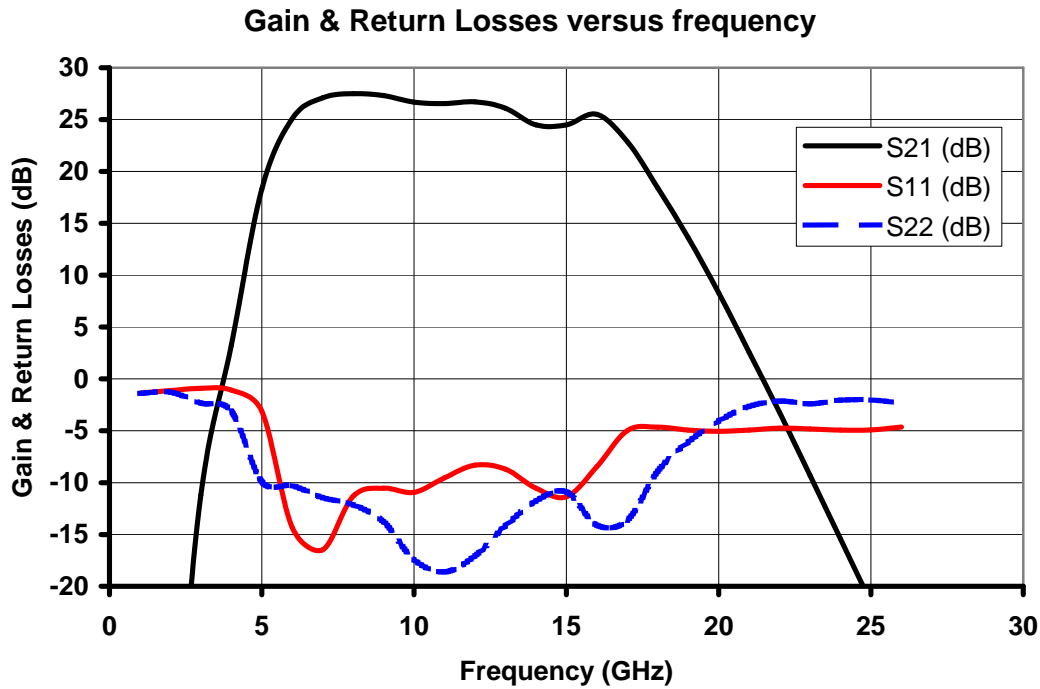

*preliminary*

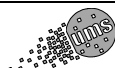
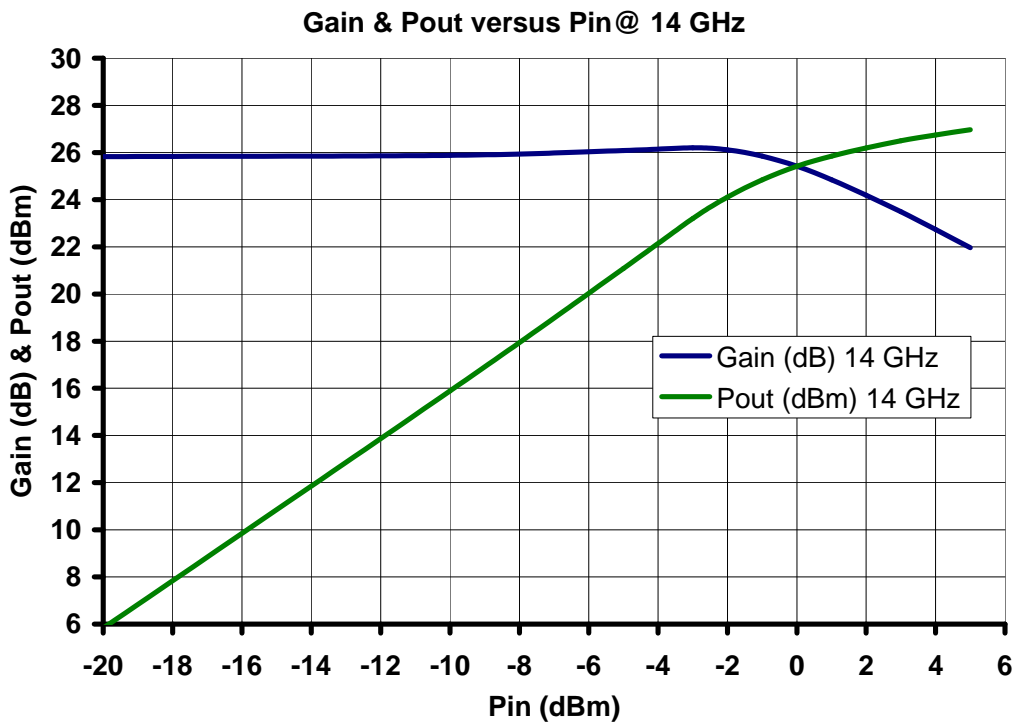
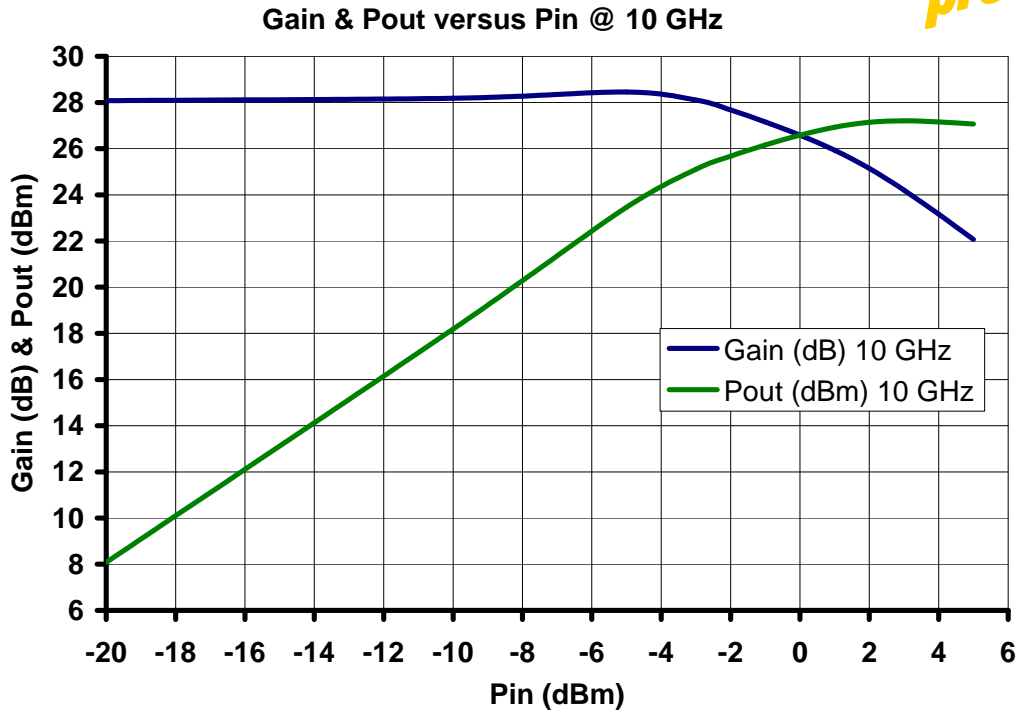

## Typical Chip on wafer Sij parameters

Tamb.=+25°C, Vd1=+4.5V, Id=310mA

*preliminary*

Freq (GHz)	dB(S11)	P(S11) (°)	dB(S21)	P(S21) (°)	dB(S12)	P(S12) (°)	dB(S22)	P(S22) (°)
1,0	-1,4	118	-57,3	-37	-55,8	-122	-1,4	117
2,0	-1,1	65	-40,7	-48	-62,5	124	-1,3	57
3,0	-0,9	19	-11,2	-137	-81,2	167	-2,3	-0
4,0	-1,1	-25	3,2	111	-58,6	-18	-3,1	-46
5,0	-3,1	-81	18,3	4	-57,6	127	-9,9	-56
6,0	-14,3	-148	25,1	-108	-63,9	-162	-10,3	-77
7,0	-16,5	-11	27,1	154	-60,3	30	-11,4	-93
8,0	-11,3	-45	27,5	72	-62,5	108	-12,1	-117
9,0	-10,5	-72	27,3	2	-60,1	-155	-13,8	-140
10,0	-10,9	-92	26,7	-60	-53,2	-84	-17,4	-161
11,0	-9,5	-113	26,5	-116	-47,5	-113	-18,6	-174
12,0	-8,3	-151	26,7	-174	-47,0	-159	-17,1	145
13,0	-8,7	160	26,1	123	-43,6	170	-14,2	86
14,0	-10,5	116	24,5	71	-37,5	149	-11,8	25
15,0	-11,4	92	24,5	20	-41,4	103	-10,9	-15
16,0	-8,5	79	25,5	-44	-39,2	79	-14,1	-55
17,0	-5,0	37	22,9	-124	-46,3	75	-13,6	-4
18,0	-4,7	4	18,4	170	-75,8	-147	-8,9	-18
19,0	-4,9	-17	13,6	112	-55,6	74	-6,1	-32
20,0	-5,1	-35	8,3	58	-52,8	29	-4,1	-49
21,0	-4,9	-50	2,6	10	-48,1	168	-2,7	-67
22,0	-4,8	-65	-3,2	-32	-47,3	150	-2,1	-85
23,0	-4,8	-80	-9,3	-72	-44,7	117	-2,4	-100
24,0	-4,9	-92	-15,4	-104	-47,0	107	-2,0	-109
25,0	-4,9	-104	-21,5	-132	-55,8	55	-2,0	-121
26,0	-4,6	-120	-26,7	-164	-50,9	170	-2,3	-134

Typical Measured Performance in test fixture

Vd1=+4.5V, Id=310mA

*preliminary*

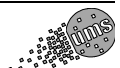
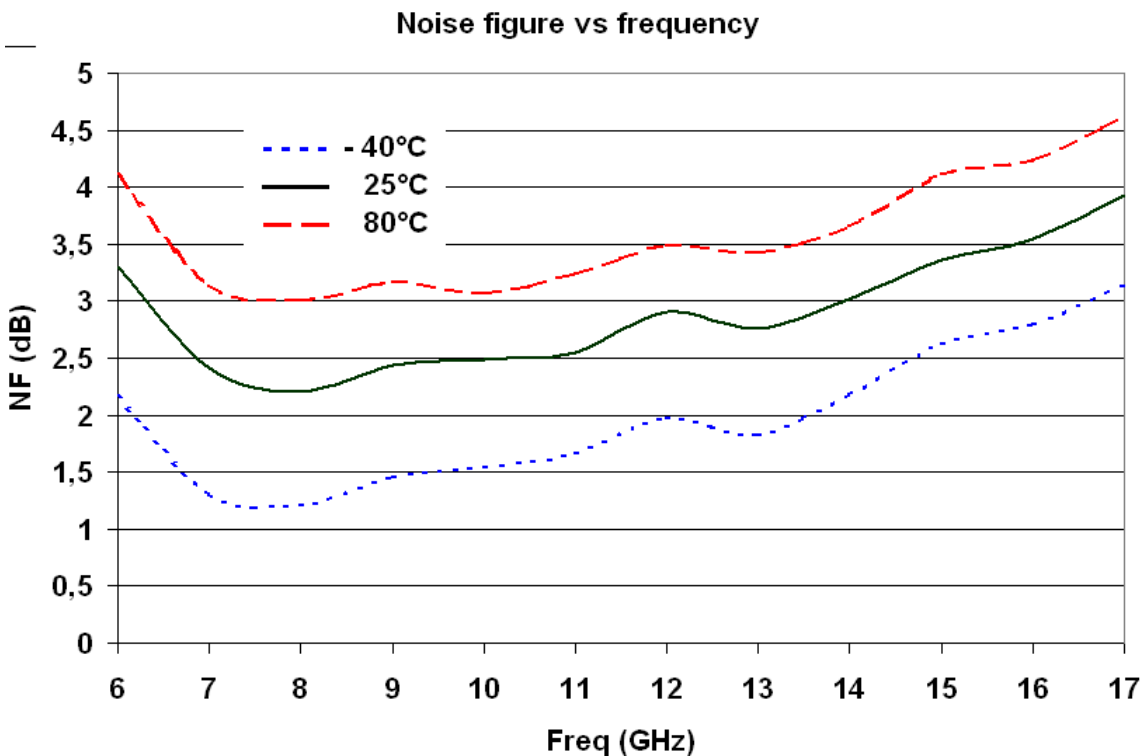
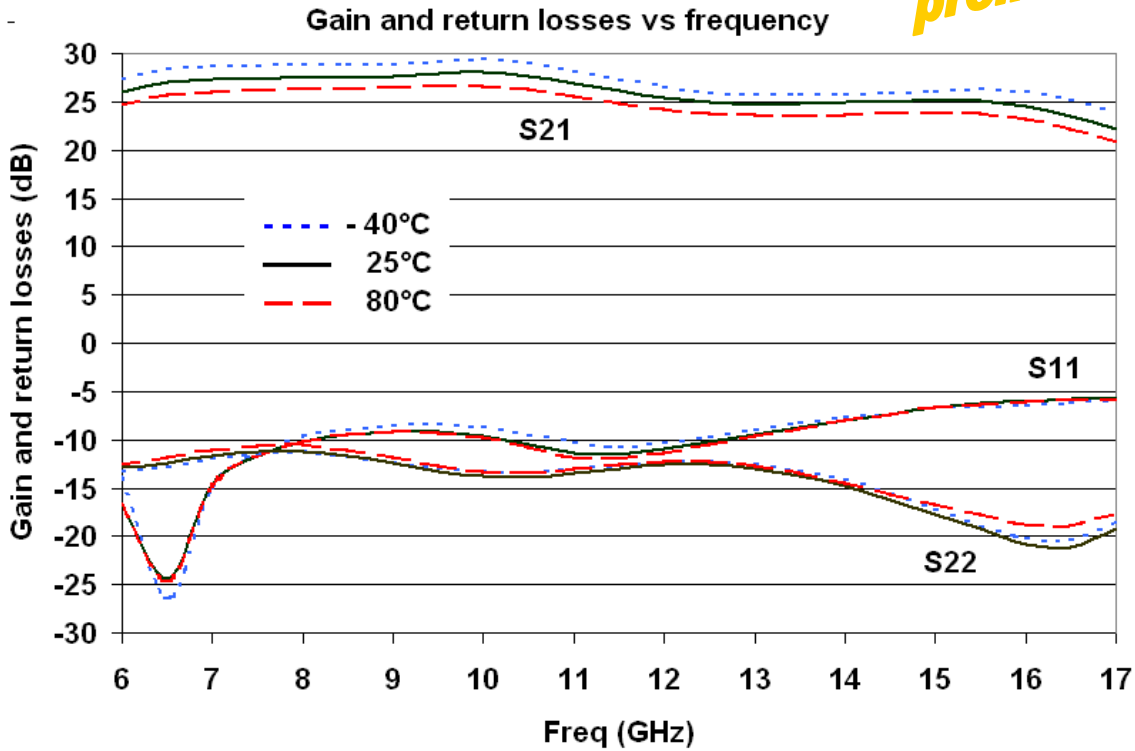

*preliminary*

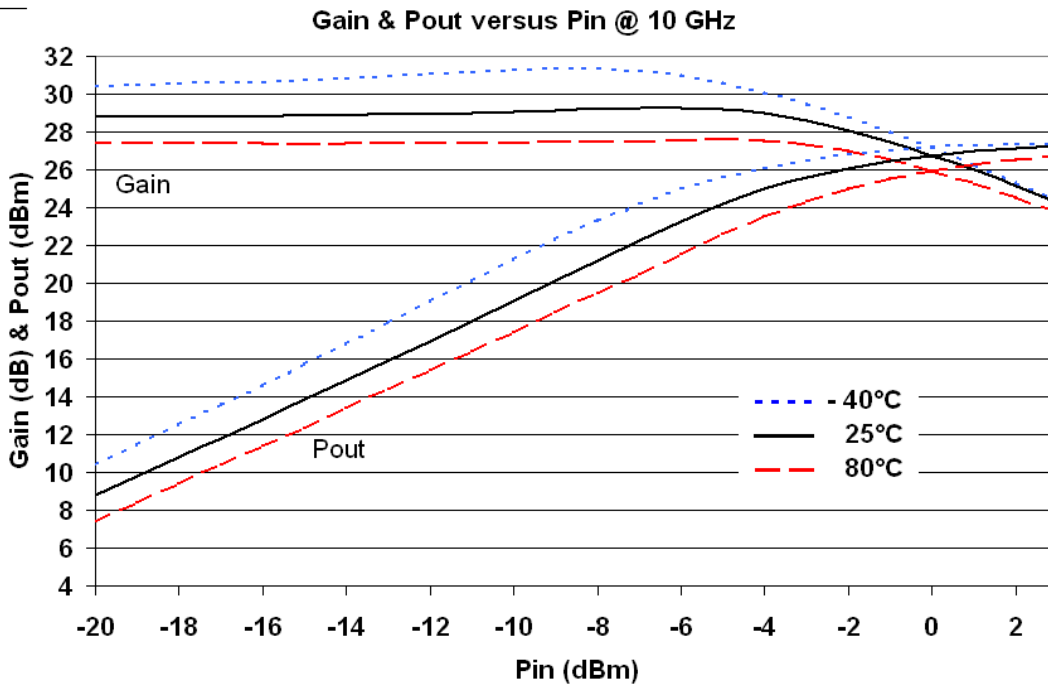
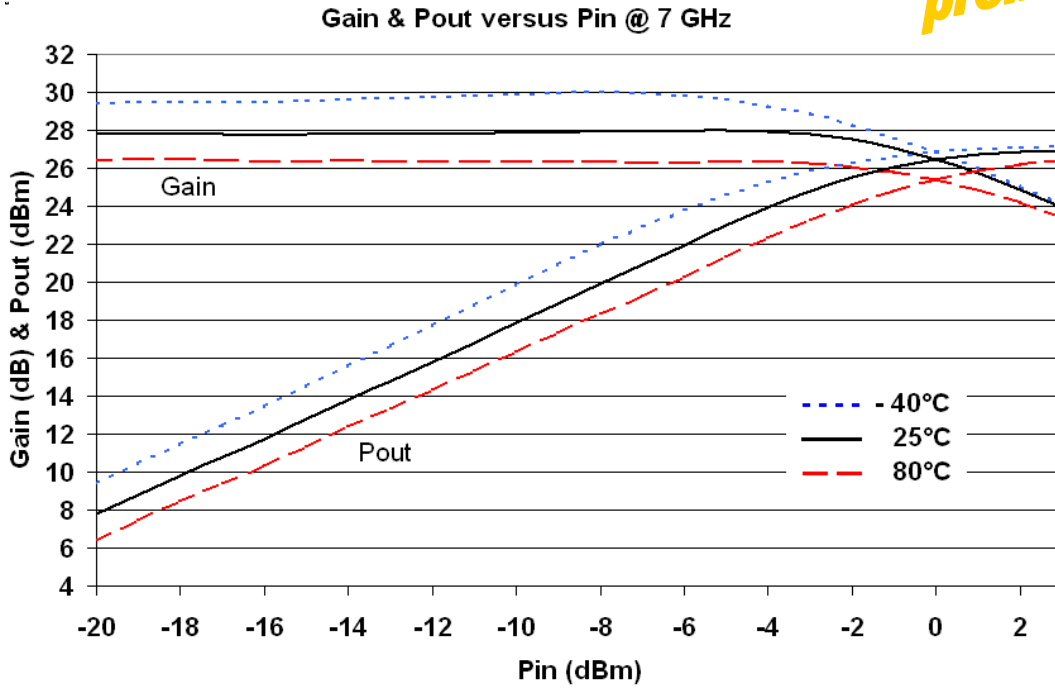

*preliminary*

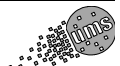
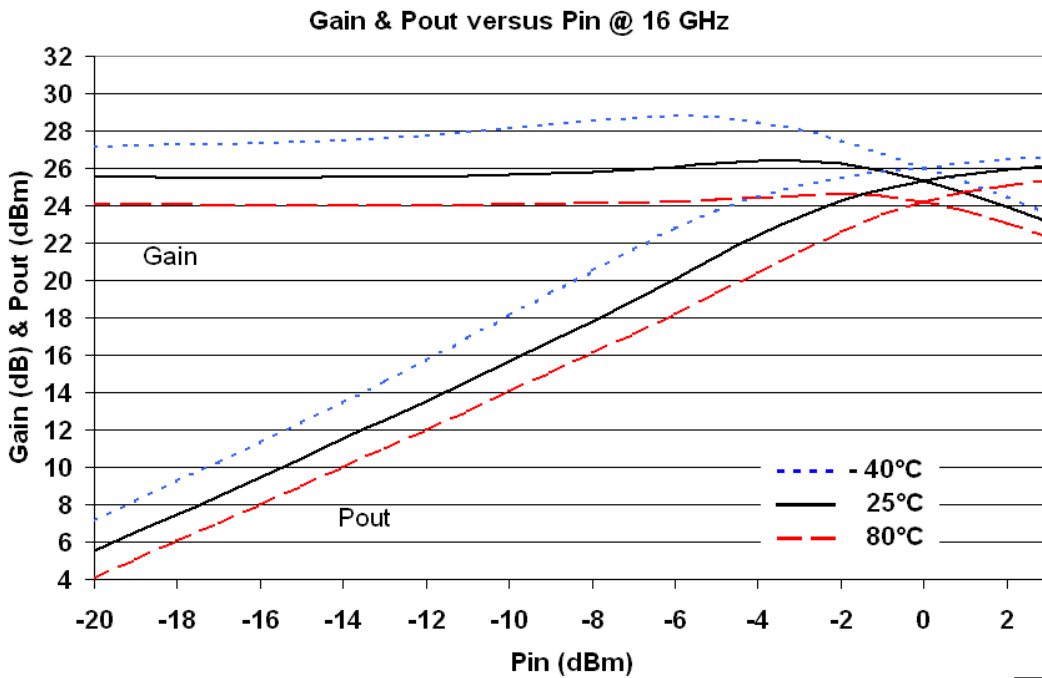
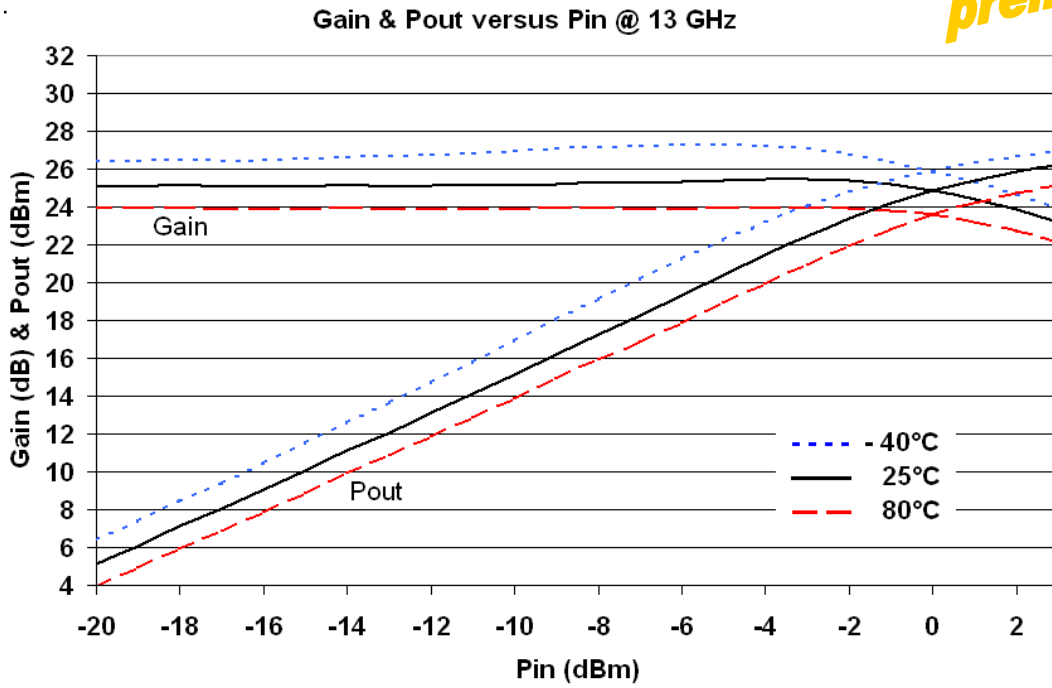

# 7-16GHz Medium Power Amplifier

CHA5051

*preliminary*

Output IP3 (dBm) vs output power @ 7 GHz

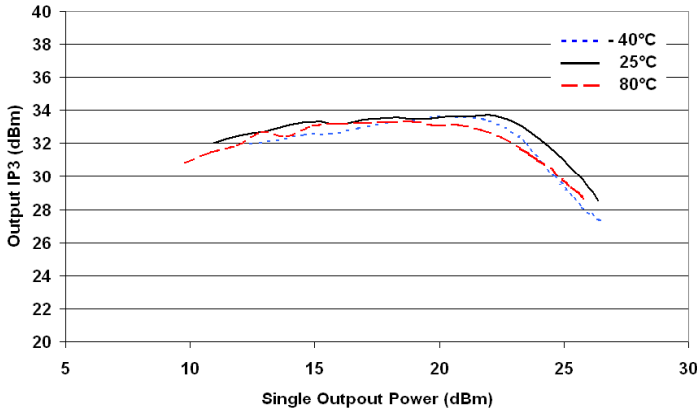

Output IP3 (dBm) vs output power @ 10 GHz

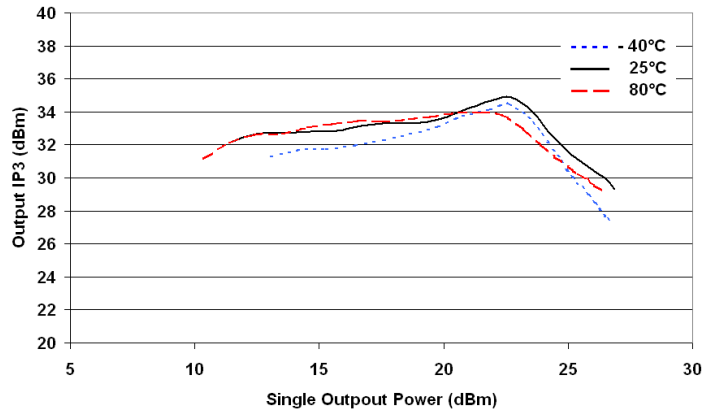

Output IP3 (dBm) vs output power @ 13 GHz

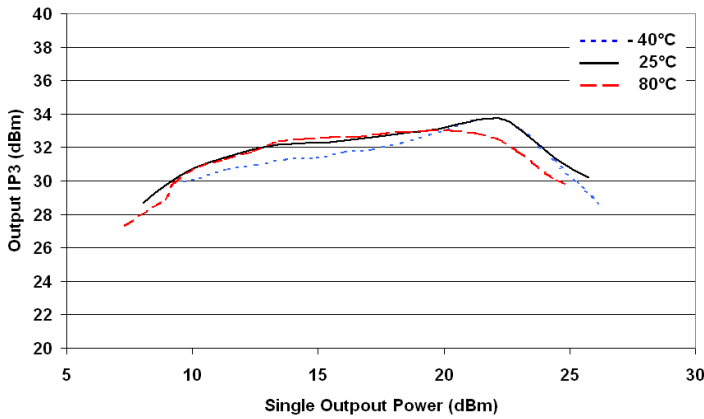

Output IP3 (dBm) vs output power @ 16 GHz

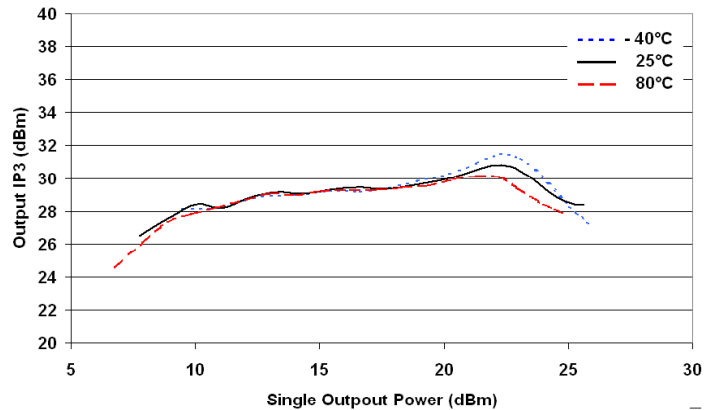

*preliminary*

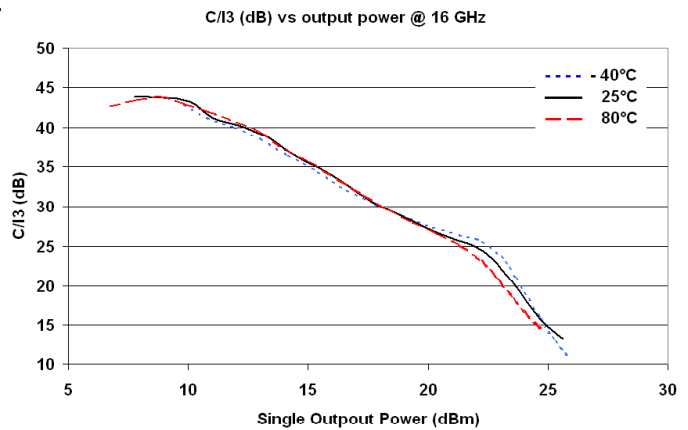
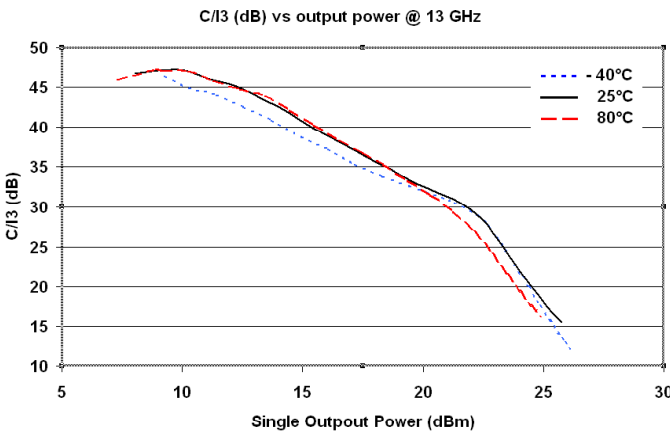
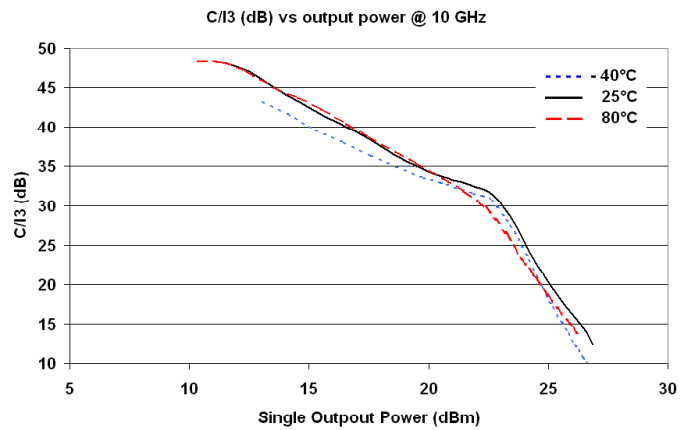
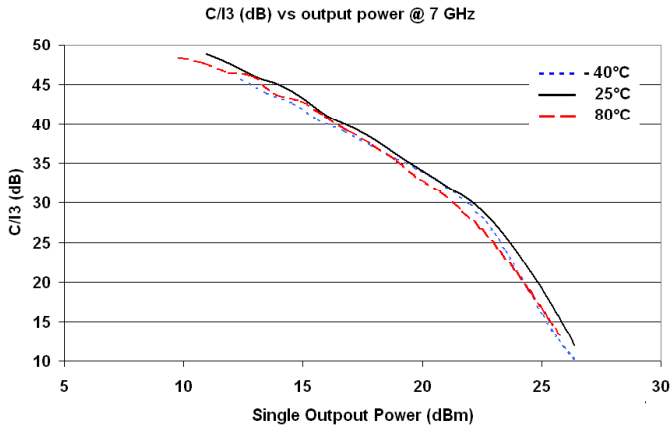

# 7-16GHz Medium Power Amplifier

CHA5051

*preliminary*

Id vs input power @ 7 GHz

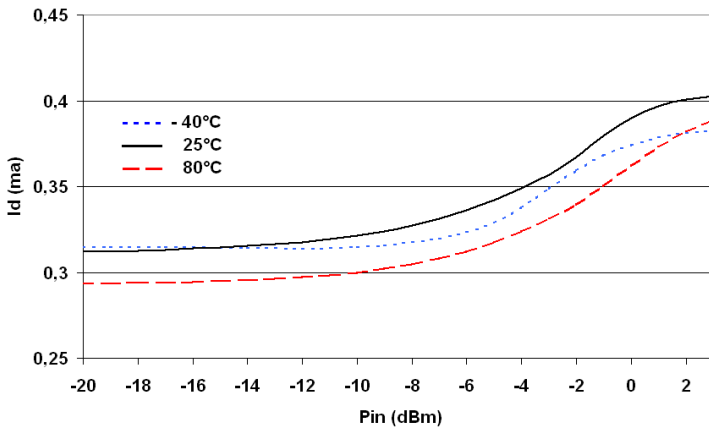

Id vs input power @ 10 GHz

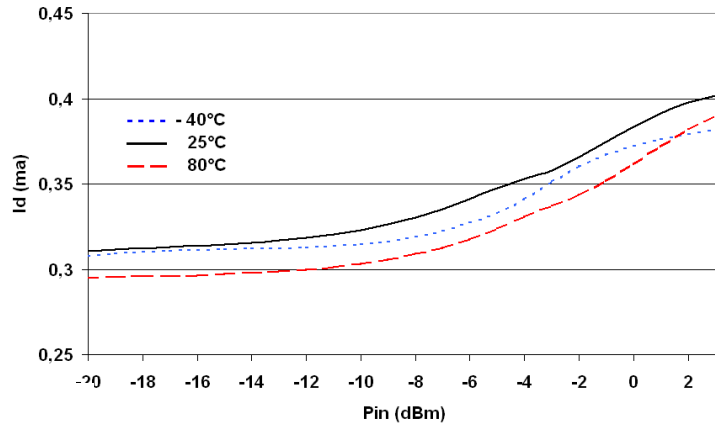

Id vs input power @ 13 GHz

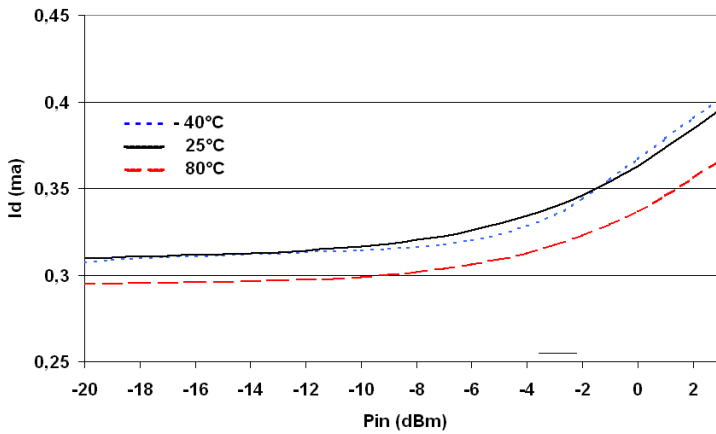

Id vs input power @ 16 GHz

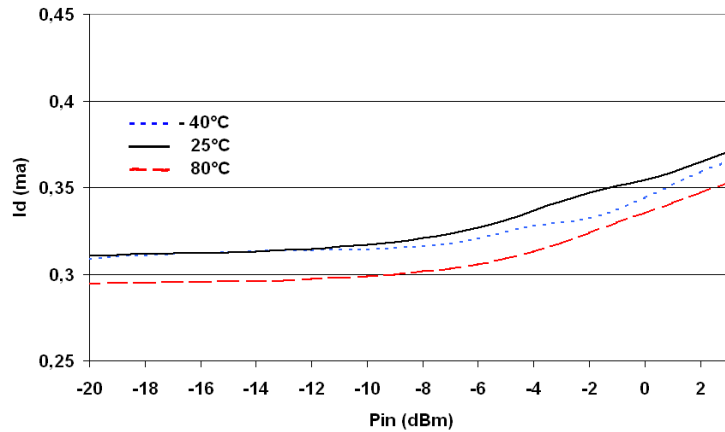

*preliminary*

Gain control with Vg vs frequency

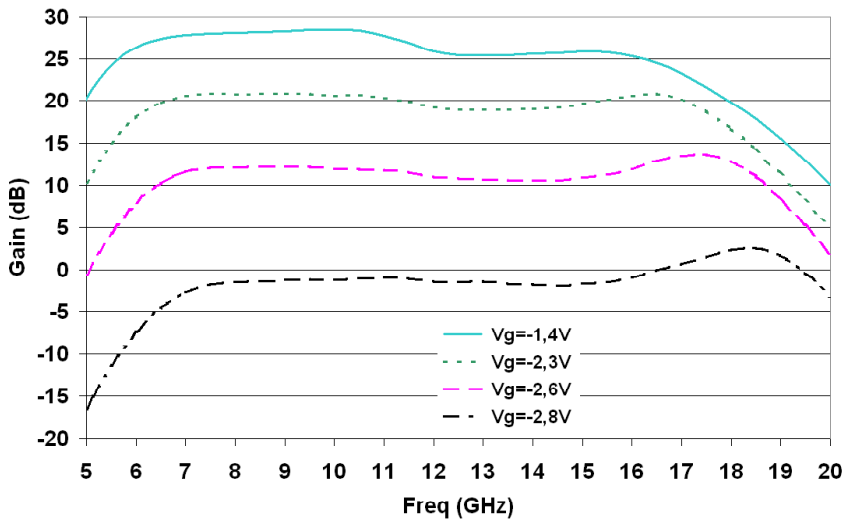

Associated return losses

Input return loss vs frequency

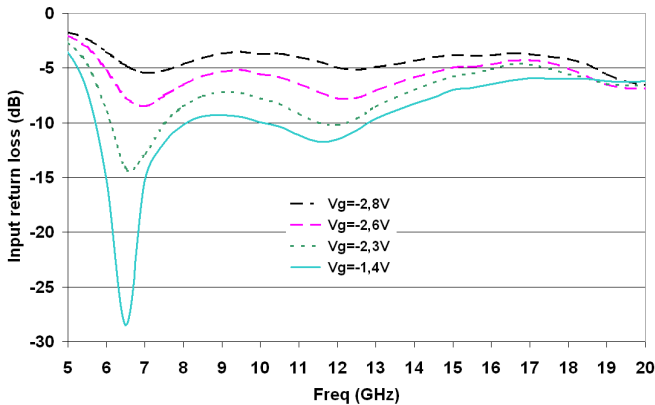

Output return loss vs frequency

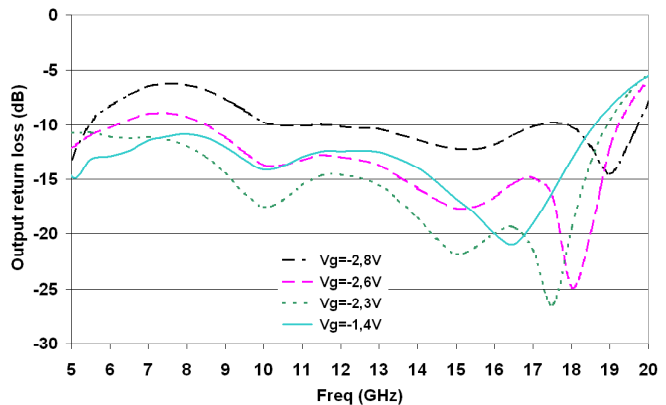

**Note**

Due to ESD protection circuits on RF input and output, an external capacitance might be requested to isolate the product from external voltage that could be present on the RF accesses.

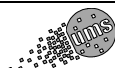
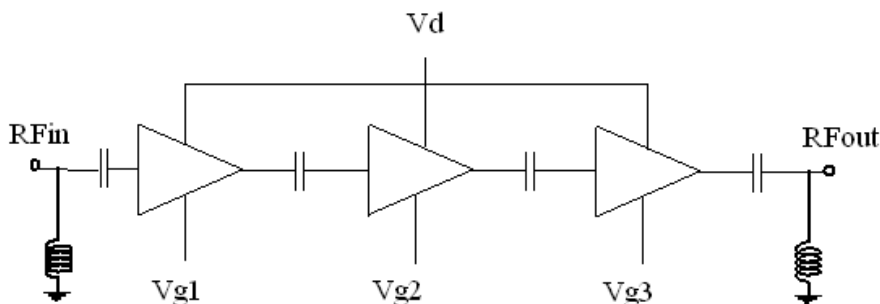

## Chip Assembly and Mechanical Data

*preliminary*

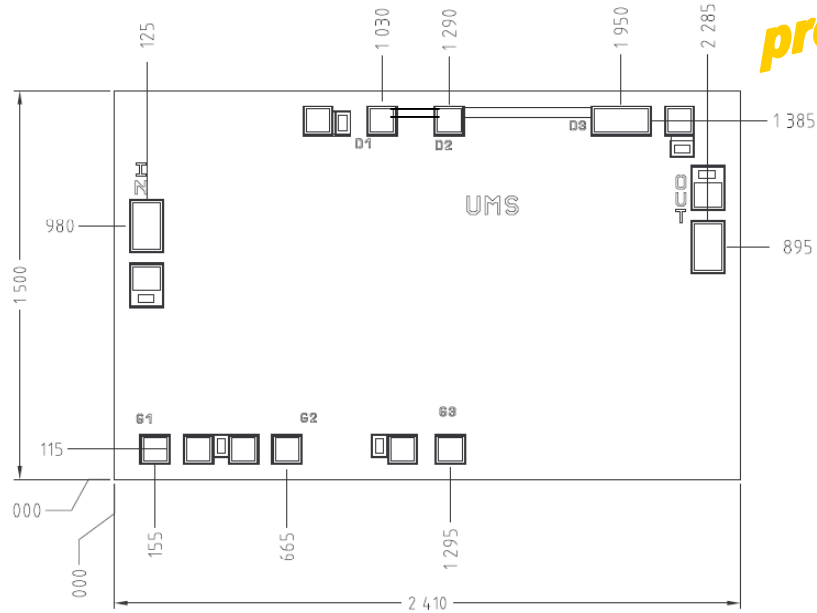

UNITS :  $\mu\text{m}$   
Tol :  $\pm 35\mu\text{m}$

- Note :** 25 $\mu\text{m}$  diameter gold wire is to be preferred.
- DC Pad size : 100/100 $\mu\text{m}$ .
- RF wire bondings should be as short as possible, lower than 0.35mm.
- Chip thickness : 100 $\mu\text{m}$ .

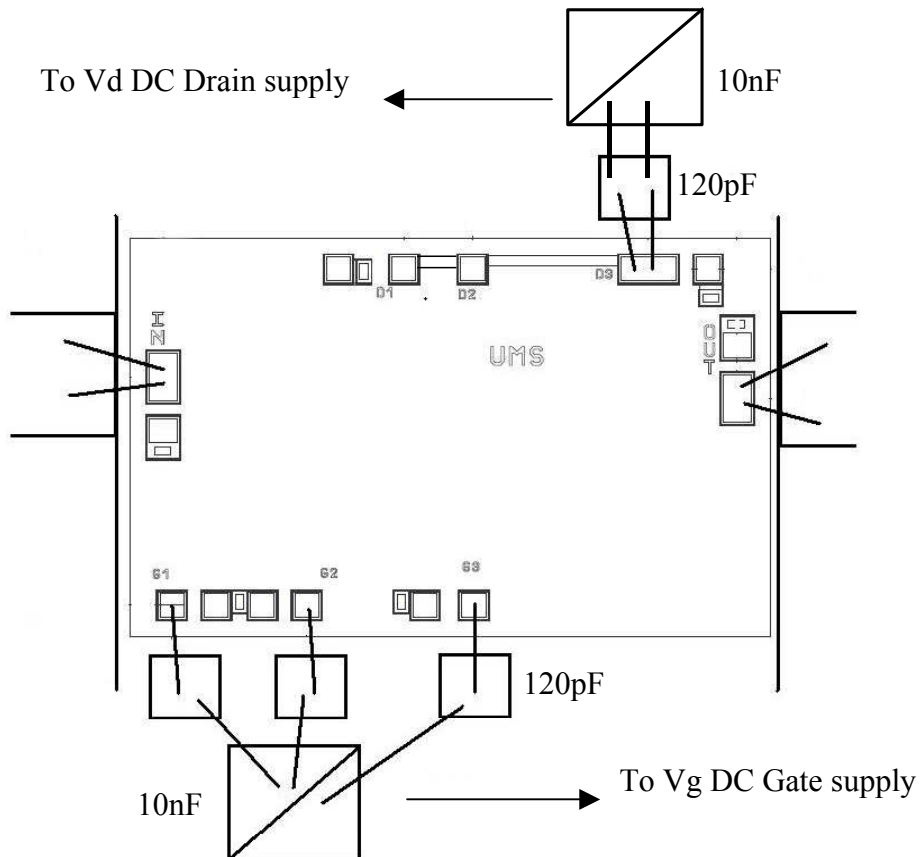

*preliminary*

## Ordering Information

Chip form:           CHA5051-98F/00

Information furnished is believed to be accurate and reliable. However **United Monolithic Semiconductors S.A.S.** assumes no responsibility for the consequences of use of such information nor for any infringement of patents or other rights of third parties which may result from its use. No license is granted by implication or otherwise under any patent or patent rights of **United Monolithic Semiconductors S.A.S.**. Specifications mentioned in this publication are subject to change without notice. This publication supersedes and replaces all information previously supplied. **United Monolithic Semiconductors S.A.S.** products are not authorised for use as critical components in life support devices or systems without express written approval from **United Monolithic Semiconductors S.A.S.**

