

CHM

2.0 CONNECTOR SYSTEM

acc. to IEC 61076 - 4 - 101

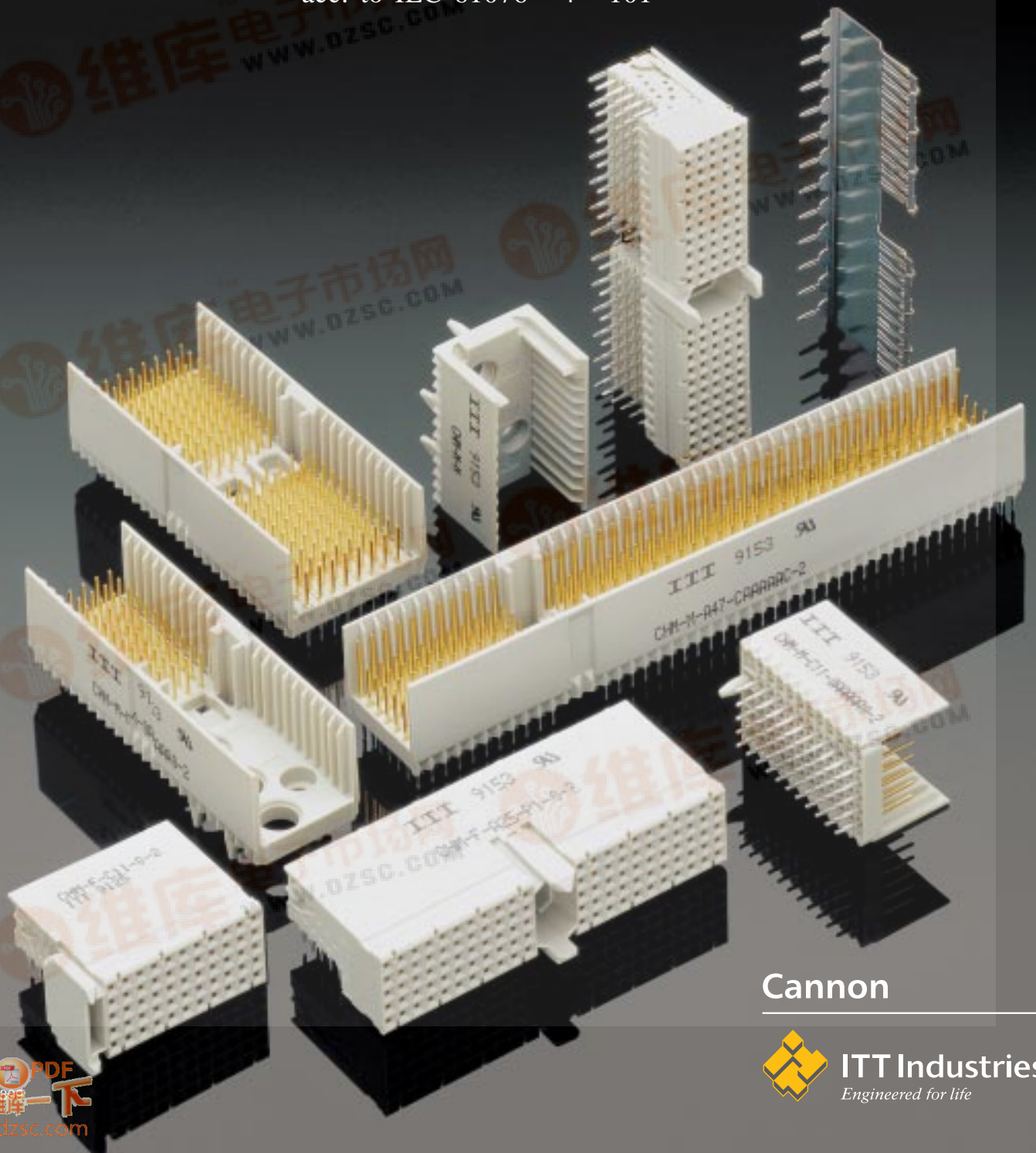

Cannon



ITT Industries
Engineered for life



Contents

Definition of Terms	3
Technical Data	4
System Modularity	5
Dimensions of Contacts	6
Male Connectors Type A	7
Female Connectors Type A	9
Male Connectors Type B	10
Female Connectors Type B	11
Male Connectors Type B-22	12
Female Connectors Type B-22	13
Male Connectors Type B-19	14
Female Connectors Type B-19	15
Male Connectors Type C	16
Female Connectors Type C	17
Male Connectors Type Compact PCI	18
Female Connectors Type Compact PCI	19
Male Connectors D	20
Male Connectors E	21
Male Connectors L	22
Male Connectors M	23
Male Connectors N	24
Shrouds A, B, B-22, B-19, C	25
Shrouds AB	26
Coding Devices	27
Tools	28
Order Number Index	32
Product Safety Information	34
Fax Request Form	35

Definition of Terms

Connector according to IEC 61076-4-101

The hardmetric connector system CHM 2.0 was developed according to the international standard IEC 61076-4-101. As a result, a worldwide standard for the combination of PCBs is safeguarded by multicontact plug-and-socket connectors for customers.

PCBs can be exchanged without problems from system to system. Important parameters like fixing, shielding and coding remain compatible to all applications.

The spacing

The CHM 2.0 connectors have been developed with a spacing of 2 mm between contacts. These connectors are modular and therefore can be stacked together without interrupting the continuity of the 2 mm design. No space is wasted within a row of connectors.

Module stacking

To improve stacking and to avoid accidental reversal of connectors the end of the housings engage the adjacent connector to insure exact positioning onto the PCB board and give the modules the necessary support.

Coding

In order to avoid accidental plug-in among PC boards the IEC 61076-4-101 standard provides protection through coding. Coding keys are easily hand inserted into the multifunction block of the connector module A, L and M. The pins are colour coded for fast visual recognition.

Multifunction block

The modules A, L, M and compact PCI are equipped with a multifunction block. The coding devices, according to the IEC standard, can be added to the multifunction block. The guides guaranty the correct mating and prohibit accidental reversal of the male and female connectors.

The coding devices may be assembled by a single plug and pulling tool and/or again removed.

Contact length of the rear and front mating area

ITT Industries Cannon offers 3 different lengths for the front mating area and 4 lengths for the rear mating area for the CHM 2.0 male connectors. A tin-plated Wire Wrap type is equally available. Different contact lengths are required for signal and ground contacts to establish first mate and last break features.

The long contacts with 11,25 mm are predominantly used for the shielding rows z and f.

Through-hole specification of the PCB

Through-plated holes for signal contacts and shieldings in press-fit techniques.

Hole Ø	0,6 mm	
Drillhole	0,68 - 0,72 mm	
Cu	min. 25 µm	
Sn	5 - 15 µm	
Plated through hole	0,55 - 0,65 mm	

Technical Data

Electrical and mechanical data

Spacing		2 mm
Temperature range		- 55°C bis +125°C
Mechanical durability	Performance class 1 Performance class 2	> 500 Mating Cycles > 250 Mating Cycles
Housing		Polyester Glass filled acc. UL 94V-0
Contact resistance acc. to IEC 512-5		max. 20mΩ
Contact material	Male contact	Bronze
	Female contact	Bronze
Male and female contact surface		Au over PdNi over Ni
Insulation resistance acc. IEC 512-5	Contact/Contact	min. 10 ⁴ MΩ
	Contact/Shield	min. 10 ⁴ MΩ
Insertion force per pin	Contact	max. 0,75 N
	Shield	max. 1 N
Extraction force per pin	Contact	min. 0,15 N
	Shield	min. 0,15 N

Test voltage

		fully loaded	every 2nd position	Chessboard
Row a, c, e Row b, d	within row	750 V _{eff}	1500 V _{eff}	--
	between rows	1500 V _{eff}	1500 V _{eff}	--
Row a, b, c Row a, b, c, d Row a, b, c, d, e	within row	750 V _{eff}	1500 V _{eff}	1500 V _{eff}
	between rows	750 V _{eff}	750 V _{eff}	1200 V _{eff}

Creepage- and air gaps

		fully loaded		every 2nd position		Chessboard	
		Male connector	Modules Female connector	Backplane Male connector	Modules Female connector	Backplane Male connector	Modules Female connector
Row a, c, e Row b, d	within row	0,8 mm	0,6 mm	2,5 mm	2,5 mm	--	--
	between rows	2,5 mm	2,5 mm	2,5 mm	2,5 mm	--	--
Row a, b, c Row a, b, c, d Row a, b, c, d, e	within row	0,8 mm	0,6 mm	2,5 mm	2,5 mm	2,5 mm	2,5 mm
	between rows	0,8 mm	0,6 mm	0,8 mm	0,6 mm	1,5 mm	1,2 mm

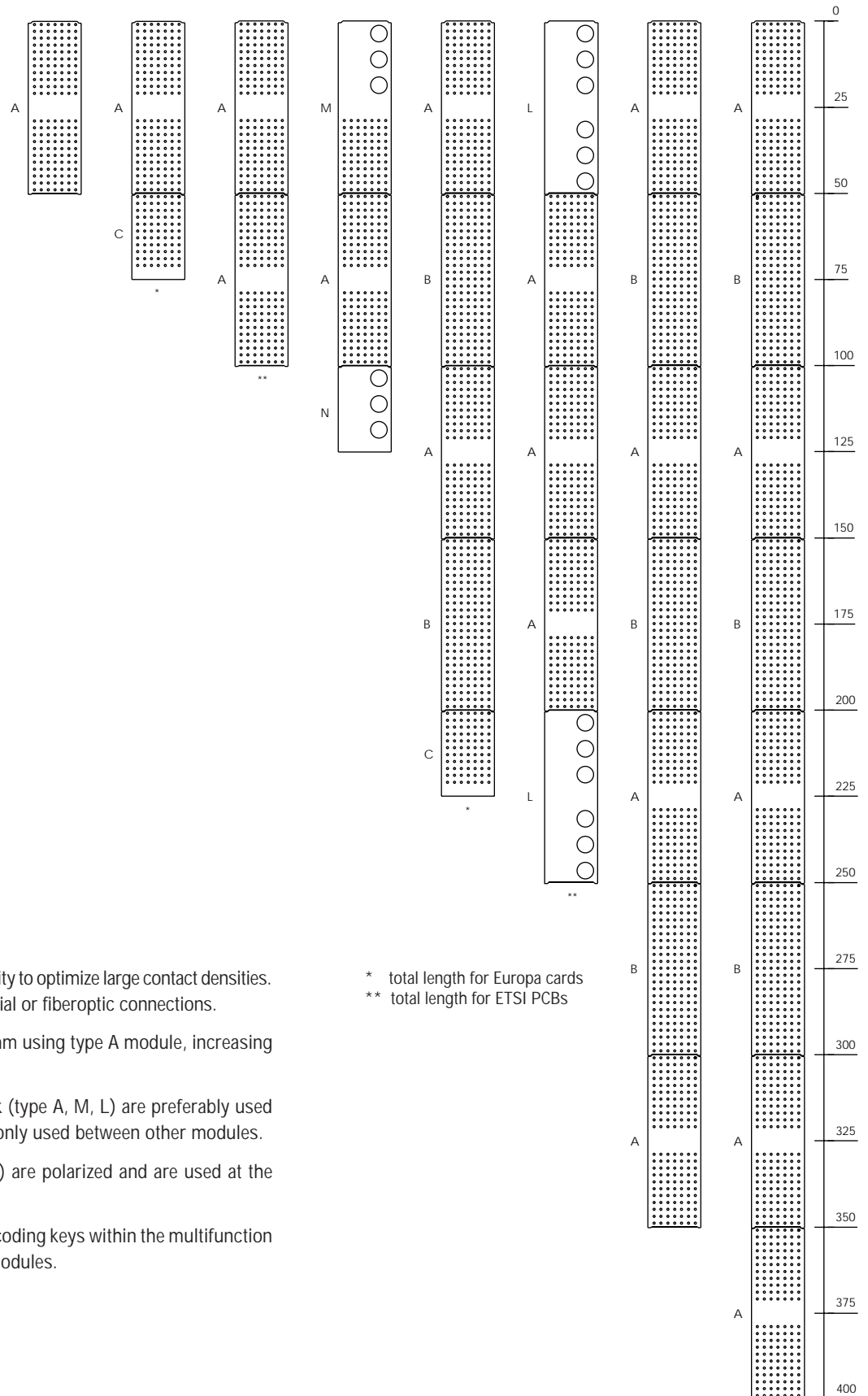

System modularity

CHM 2.0 modules offer a great versatility to optimize large contact densities. Especially the combination with coaxial or fiberoptic connections.

Stacking can be arranged from 50 mm using type A module, increasing in 25 mm steps to required lengths.

Connectors with multifunction block (type A, M, L) are preferably used at the top of any column. Type B is only used between other modules.

The modules type C and N (25 mm) are polarized and are used at the bottom end of the columns.

Correct mating is assured by use of coding keys within the multifunction block and by use of type C and N modules.

* total length for Europa cards
 ** total length for ETSI PCBs

Dimension of contacts	Contact	Options	Front mating	Used for
	A	without mating area	8,25 ±0,1	signal contact
	B		9,75 ±0,1	signal contact
	C		11,25 ±0,1	shielding
	G	Wire Wrap 13 mm on request	8,25 ±0,1	signal contact
	H		9,75 ±0,1	signal contact
	J		11,25 ±0,1	shielding
	K	with mating area 13 mm	8,25 ±0,1	signal contact
	L		9,75 ±0,1	signal contact
	M		11,25 ±0,1	shielding
	N	with mating area 14,5 mm	8,25 ±0,1	signal contact
	P		9,75 ±0,1	signal contact
	Q		11,25 ±0,1	shielding
	R	with mating area 16 mm	8,25 ±0,1	signal contact
	S		9,75 ±0,1	signal contact
	T		11,25 ±0,1	shielding



Male Connectors Type A

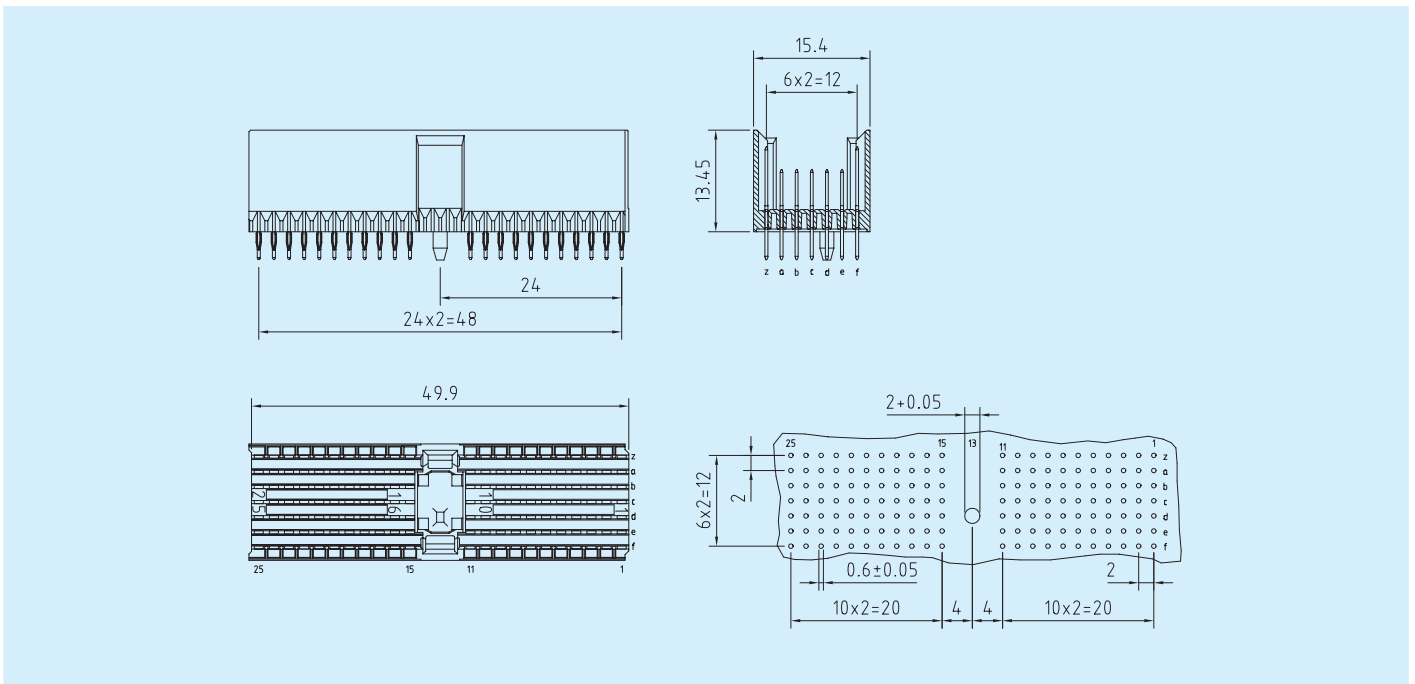

Assembly Drawing	No. of Positions	Row	Type	Pin length	Part Numbers
	110	z a b c d e f	- A A A A -	-/ 8,25/3,7 8,25/3,7 8,25/3,7 8,25/3,7 -/ -	CHM-M-A25-0AAAAA0-1 * CHM-M-A25-0AAAAA0-2**
	110	z a b c d e f	- B B B B -	-/ 9,75/3,7 9,75/3,7 9,75/3,7 9,75/3,7 -/ -	CHM-M-A25-0BBBBB0-1 * CHM-M-A25-0BBBBB0-2**
	154	z a b c d e f	C A A A A C	11,25/3,7 8,25/3,7 8,25/3,7 8,25/3,7 8,25/3,7 11,25/3,7	CHM-M-A25-CAAAAAC-1 * CHM-M-A25-CAAAAAC-2**
	154	z a b c d e f	C B B B B C	11,25/3,7 9,75/3,7 9,75/3,7 9,75/3,7 9,75/3,7 11,25/3,7	CHM-M-A25-CBBBBBC-1 * CHM-M-A25-CBBBBBC-2**
Compact PCI 	154	z a b c d e f	C B B + + B C	11,25/3,7 9,75/3,7 9,75/3,7 + + 9,75/3,7 11,25/3,7	CHM-120230-500 * CHM-120230-501**
cPCI Hot Swap 	154	z a b c d e f	C B + + + B C	11,25/3,7 9,75/3,7 + + + 9,75/3,7 11,25/3,7	CHM-120230-502 * CHM-120230-503**
cPCI Telephony Spec. 	100	z a b c d e f	- + + + + + +	- + + + + + +	CHM-120230-504 * CHM-120230-505**
	154	z a b c d e f	T P P P P P T	11,25/16,0 9,75/14,5 9,75/14,5 9,75/14,5 9,75/14,5 9,75/14,5 11,25/16,0	CHM-M-A25-TPPPPT-1 * CHM-M-A25-TPPPPT-2**

Insertion tool: Part Number 121586-5081

+ Attention: Please consider the different pin lengths in the assembly drawing.

* Performance class I > 500 mating cycles ** Performance class II > 250 mating cycles

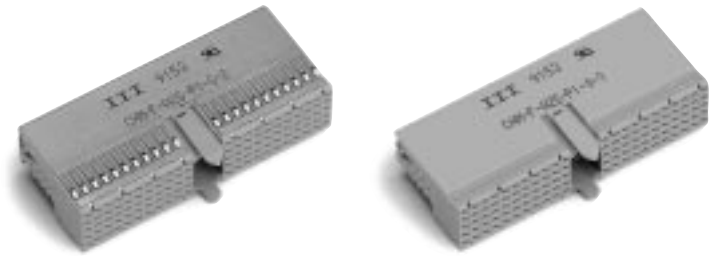

Female Connectors Type A

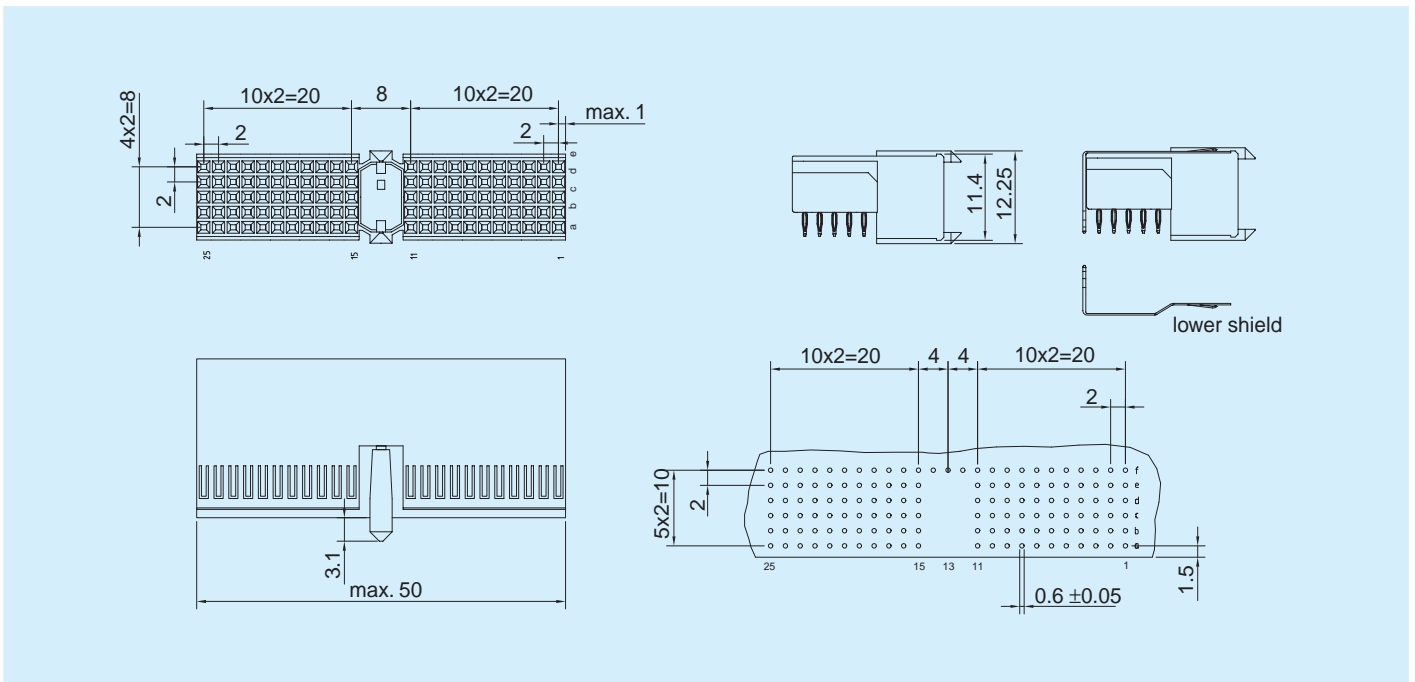

Type	No. of Positions	Part Numbers
connector without shielding	110	CHM-F-A25-P1-0-1*
		CHM-F-A25-P1-0-2**
connector with shielding	110	CHM-F-A25-P1-S-1*
		CHM-F-A25-P1-S-2**
connector with shielding cPCI Telephony Spec.	90	CHM120230-0*
		CHM120230-1**
lower shield		CHM120230-9000

* Performance class I > 500 mating cycles ** Performance class II > 250 mating cycles



Male Connectors Type B

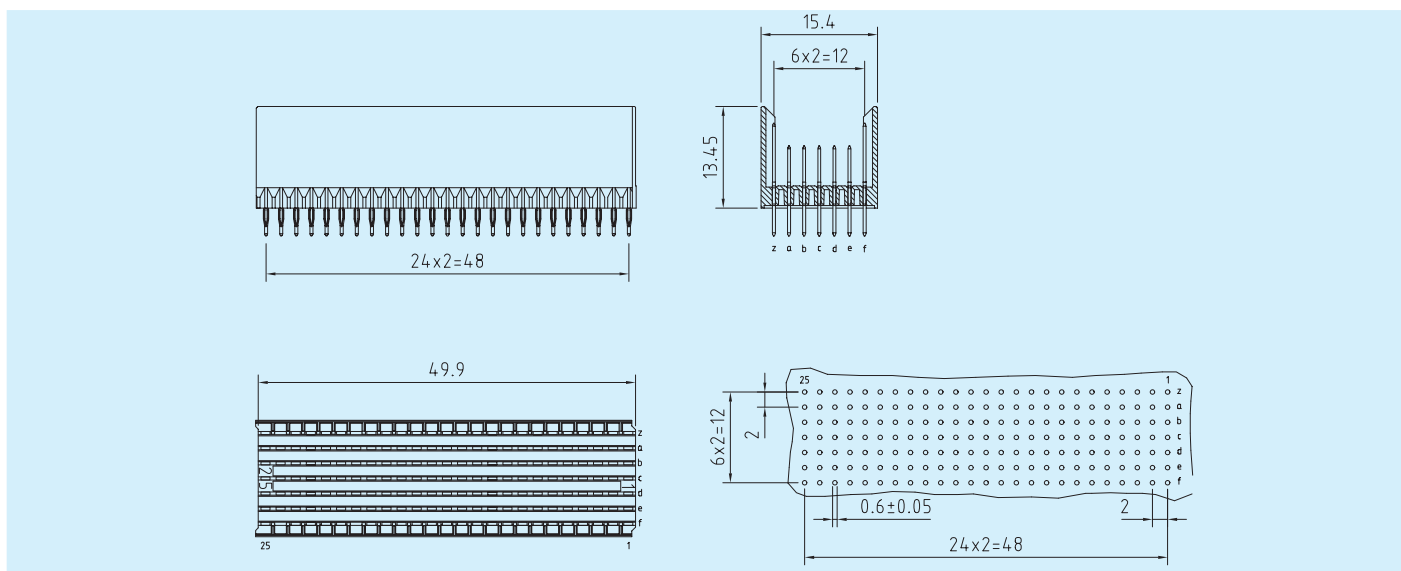

Assembly Drawing	No. of Positions	Row	Type	Pin length	Part Numbers
	125	z a b c d e f	- A A A A A -	-/- 8,25/3,7 8,25/3,7 8,25/3,7 8,25/3,7 8,25/3,7 -/-	CHM-M-B25-0AAAAA0-1 * CHM-M-B25-0AAAAA0-2**
	125	z a b c d e f	- B B B B B -	-/- 9,75/3,7 9,75/3,7 9,75/3,7 9,75/3,7 9,75/3,7 -/-	CHM-M-B25-0BBBBB0-1 * CHM-M-B25-0BBBBB0-2**
	175	z a b c d e f	- A A A A A C	11,25/3,7 8,25/3,7 8,25/3,7 8,25/3,7 8,25/3,7 8,25/3,7 11,25/3,7	CHM-M-B25-CAAAAC-1 * CHM-M-B25-CAAAAC-2**
	175	z a b c d e f	- B B B B B C	11,25/3,7 9,75/3,7 9,75/3,7 9,75/3,7 9,75/3,7 9,75/3,7 11,25/3,7	CHM-M-B25-CBBBBBC-1 * CHM-M-B25-CBBBBBC-2**

Insertion Tool: Part Number 121586-5083

* Performance class I > 500 mating cycles ** Performance class II > 250 mating cycles

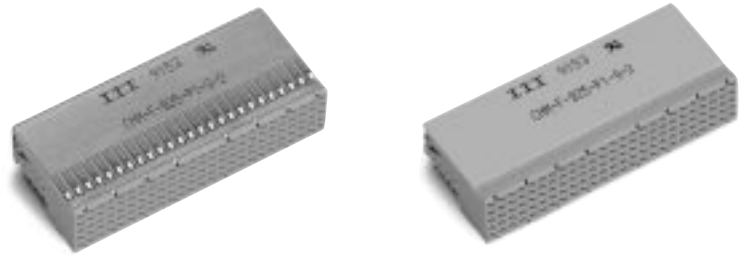

Female Connectors Type B

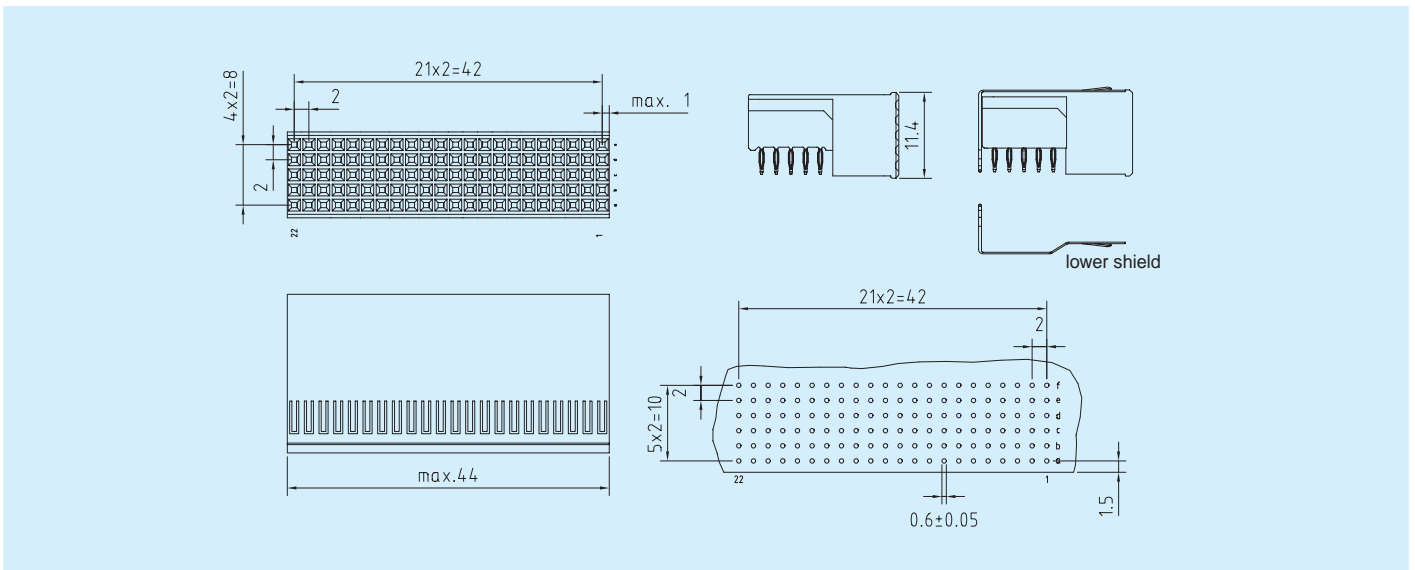

Type	No. of Positions	Part Numbers
connector without shielding	125	CHM-F-B25-P1-0-1*
		CHM-F-B25-P1-0-2**
connector with shielding	125	CHM-F-B25-P1-S-1*
		CHM-F-B25-P1-S-2**
lower shield		CHM120230-9001

* Performance class I > 500 mating cycles ** Performance class II > 250 mating cycles



Male Connectors Type B-22 (Compact PCI P2/P5)

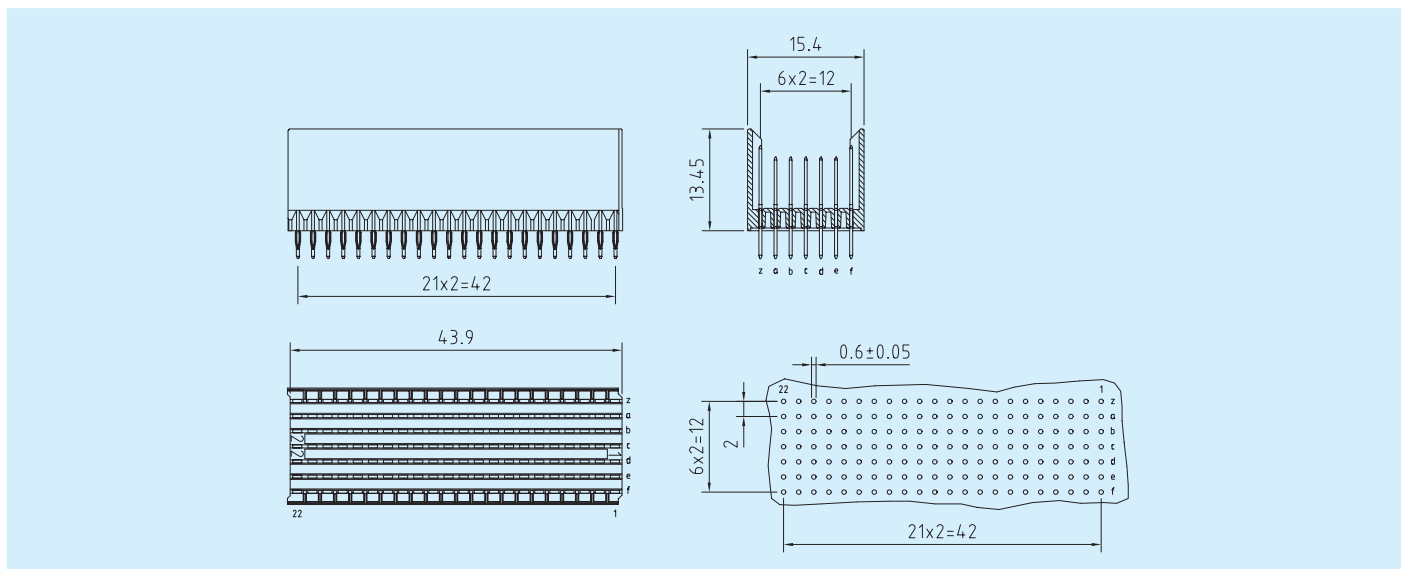

Assembly Drawing	No. of Positions	Row	Type	Pin length	Part Numbers
	154	z a b c d e f	C A A A A A C	11,25/37 8,25/3,7 8,25/3,7 8,25/3,7 8,25/3,7 8,25/3,7 11,25/37	CHM-M-B22-CAAAAAC-1 * CHM-M-B22-CAAAAAC-2**
	154	z a b c d e f	C * * * * * C	11,25/3,7 8,25/3,7 8,25/3,7 8,25/3,7 8,25/3,7 8,25/3,7 11,25/3,7	CHM120230-506 * CHM120230-507**
	154	z a b c d e f	C B B B B B C	11,25/3,7 9,75/3,7 9,75/3,7 9,75/3,7 9,75/3,7 9,75/3,7 11,25/3,7	CHM-M-B22-CBBBBBC-1 * CHM-M-B22-CBBBBBC-2**
	154	z a b c d e f	T P P P P P T	11,25/16,0 9,75/14,5 9,75/14,5 9,75/14,5 9,75/14,5 9,75/14,5 11,25/16,0	CHM-M-B22-TPPPPPT-1 * CHM-M-B22-TPPPPPT-2**

Insertion Tool: Part Number 121586-5084

* Performance class I > 500 mating cycles ** Performance class II > 250 mating cycles



Female Connectors Type B-22 (Compact PCI J2/J5)

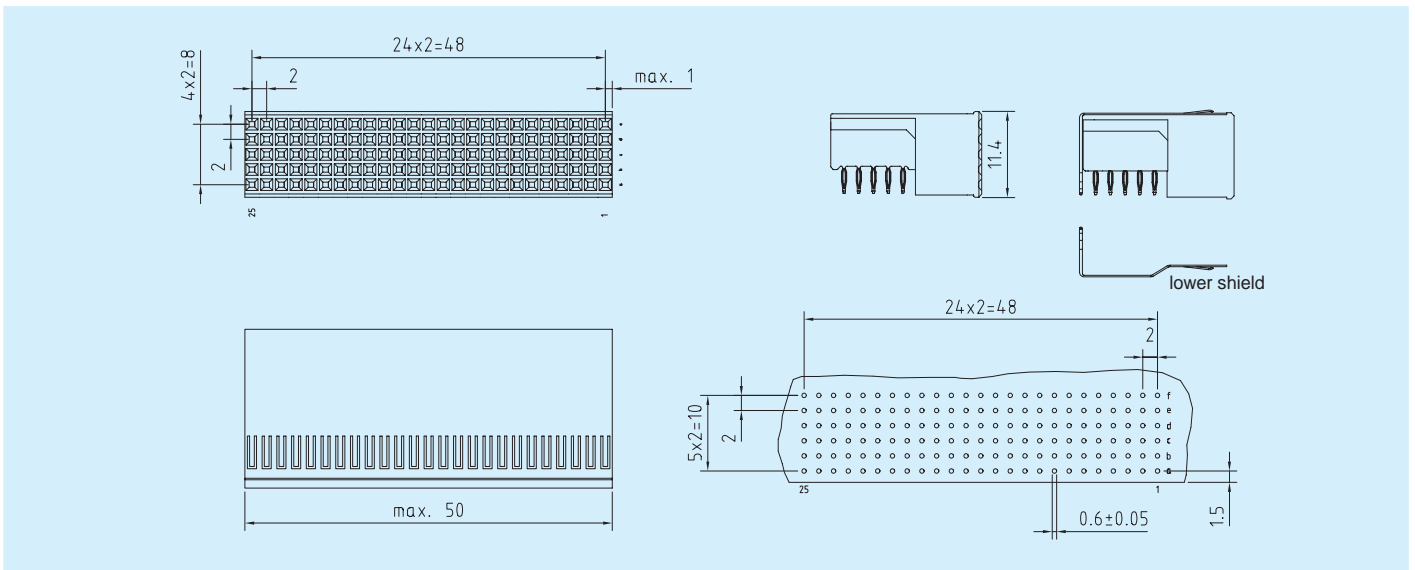

Type	No. of Positions	Part Numbers
connector without shielding	110	CHM-F-B22-P1-0-1*
		CHM-F-B22-P1-0-2**
connector with shielding	110	CHM-F-B22-P1-S-1*
		CHM-F-B22-P1-S-2**
lower shield		CHM120230-9002

* Performance class I > 500 mating cycles ** Performance class II > 250 mating cycles



Male Connectors Type B-19 (VME J0 und C-PCI P3)

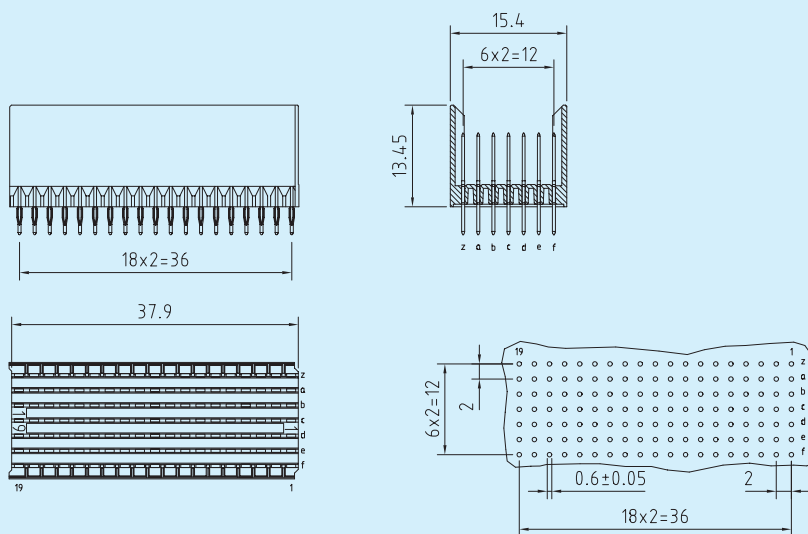

Assembly Drawing	No. of Positions	Row	Type	Pin length	Part Numbers
	95	z a b c d e f	- A A A A A -	-/ 8,25/3,7 8,25/3,7 8,25/3,7 8,25/3,7 8,25/3,7 -/-	CHM-M-B19-0AAAAA0-1 * CHM-M-B19-0AAAAA0-2**
	133	z a b c d e f	C A A A A A C	11,25/3,7 8,25/3,7 8,25/3,7 8,25/3,7 8,25/3,7 8,25/3,7 11,25/3,7	CHM-M-B19-CAAAAC-1 * CHM-M-B19-CAAAAC-2**
	133	z a b c d e f	C B B B B B C	11,25/3,7 9,75/3,7 9,75/3,7 9,75/3,7 9,75/3,7 9,75/3,7 11,25/3,7	CHM-M-B19-CBBBBBC-1 * CHM-M-B19-CBBBBBC-2**
	133	z a b c d e f	T P P P P P T	11,25/16,0 9,75/14,5 9,75/14,5 9,75/14,5 9,75/14,5 9,75/14,5 11,25/16,0	CHM-M-B19-TPPPPPT-1 * CHM-M-B19-TPPPPPT-2**

Insertion Tool: Part Number 121586-5083

* Performance class I > 500 mating cycles ** Performance class II > 250 mating cycles

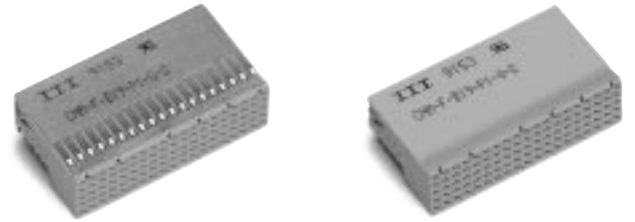

Female Connectors Type B-19 (VME P0 und C-PCI J3)

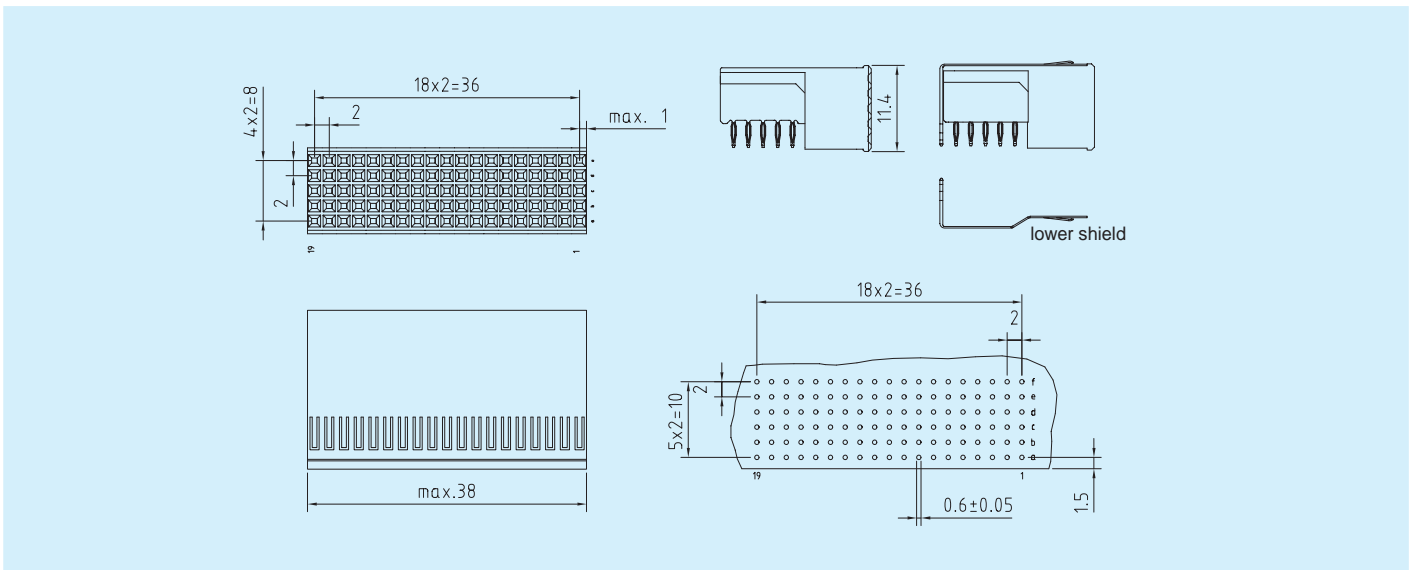

Type	No. of Positions	Part Numbers
connector without shielding	95	CHM-F-B19-P1-0-1*
		CHM-F-B19-P1-0-2**
connector with shielding	95	CHM-F-B19-P1-S-1*
		CHM-F-B19-P1-S-2**
lower shield		CHM120230-9003

* Performance class I > 500 mating cycles ** Performance class II > 250 mating cycles



Male Connectors Type C

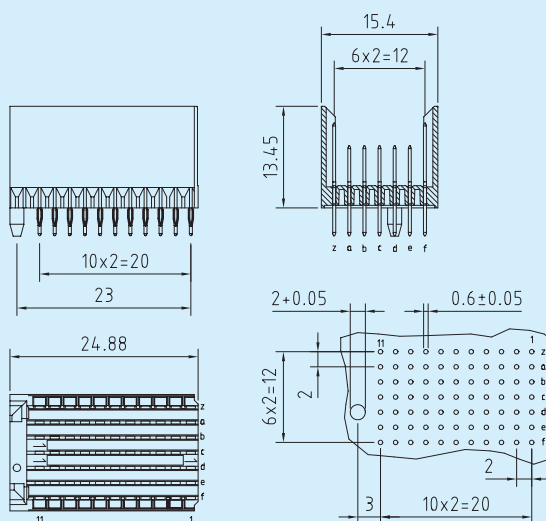

Assembly Drawing	No. of Positions	Row	Type	Pin length	Part Numbers
	55	z a b c d e f	- A A A A A -	-/ 8,25/3,7 8,25/3,7 8,25/3,7 8,25/3,7 8,25/3,7 -/-	CHM-M-C11-0AAAAA0-1 * CHM-M-C11-0AAAAA0-2**
	55	z a b c d e f	- B B B B B -	-/ 9,75/3,7 9,75/3,7 9,75/3,7 9,75/3,7 9,75/3,7 -/-	CHM-M-C11-0BBBBB0-1 * CHM-M-C11-0BBBBB0-2**
	77	z a b c d e f	C A A A A A A	11,25/3,7 8,25/3,7 8,25/3,7 8,25/3,7 8,25/3,7 8,25/3,7 11,25/3,7	CHM-M-C11-CAAAAC-1 * CHM-M-C11-CAAAAC-2**
	77	z a b c d e f	C B B B B B C	11,25/3,7 9,75/3,7 9,75/3,7 9,75/3,7 9,75/3,7 9,75/3,7 11,25/3,7	CHM-M-C11-CBBBBBC-1 * CHM-M-C11-CBBBBBC-2**

Insertion Tool: Part Number 121586-5087

* Performance class I > 500 mating cycles ** Performance class II > 250 mating cycles



Female Connectors Type C

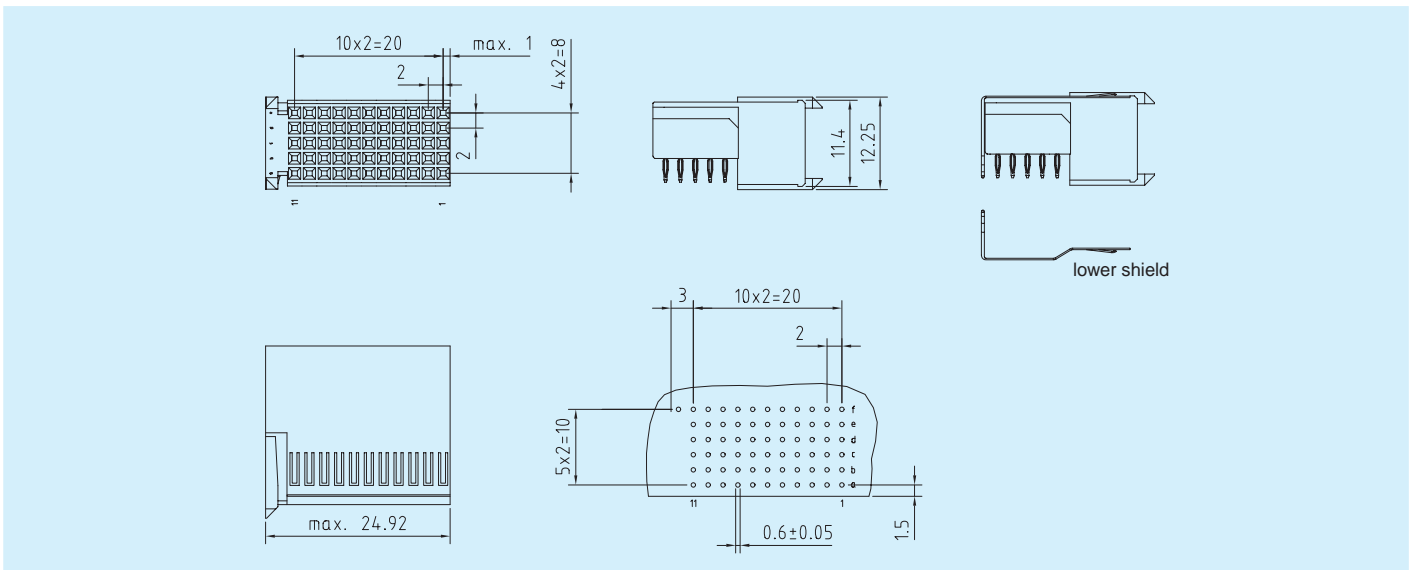

Type	No. of Positions	Part Numbers
connector without shielding	55	CHM-F-C11-P1-0-1*
		CHM-F-C11-P1-0-2**
connector with shielding	55	CHM-F-C11-P1-S-1*
		CHM-F-C11-P1-S-2**
lower shield		CHM120230-9006

* Performance class I > 500 mating cycles ** Performance class II > 250 mating cycles



Male Connectors Type Compact PCI (P1+P2/P4+P5)

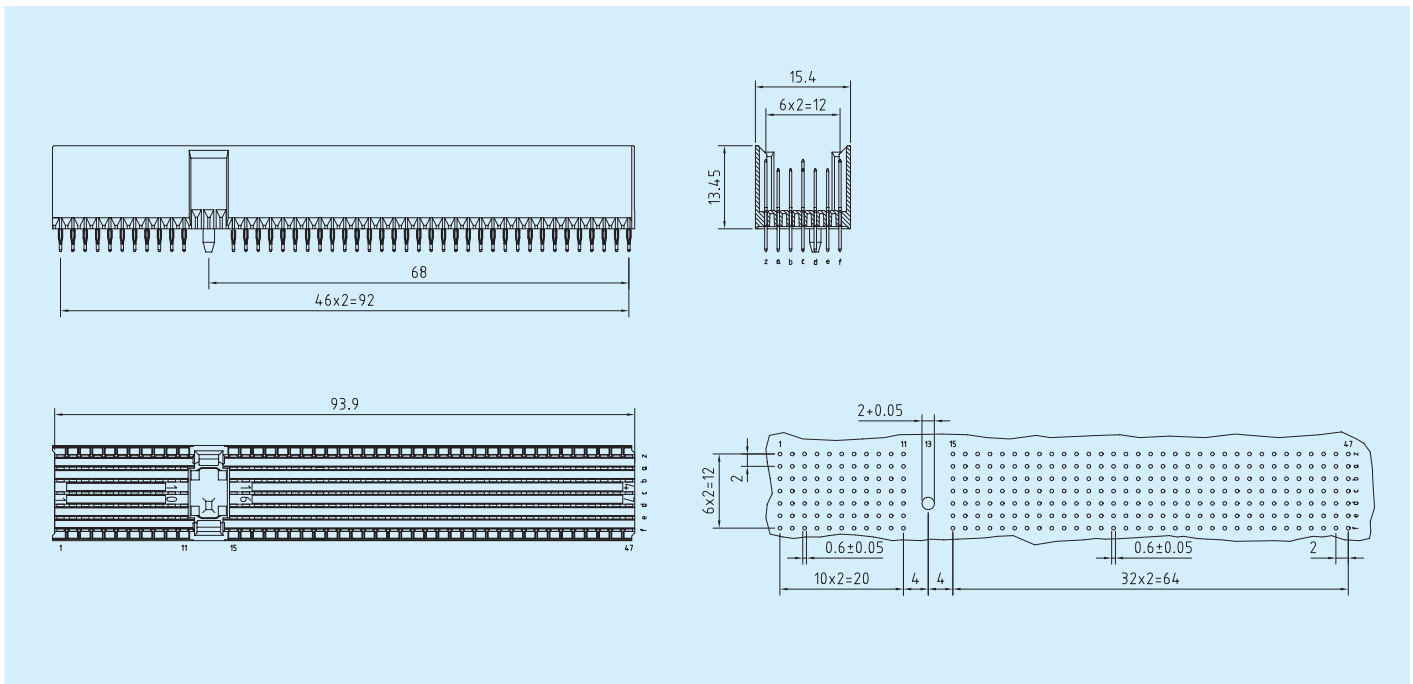

Assembly Drawing	No. of Pos.	Row	Type	Pin length	Part Numbers
	308	z a b c d e f	C B B + + B C	11,25/3,7 9,75/3,7 9,75/3,7 + /3,7 + /3,7 9,75/3,7 11,25/3,7	CHM-120230-508 * CHM-120230-509**
	308	z a b c d e f	C A A A A A C	11,25/3,7 8,25/3,7 8,25/3,7 8,25/3,7 8,25/3,7 8,25/3,7 11,25/3,7	CHM-M-A47-CAAAAAC-1* CHM-M-A47-CAAAAAC-2**
	308	z a b c d e f	T P P P P P T	11,25/16,0 9,75/14,5 9,75/14,5 9,75/14,5 9,75/14,5 9,75/14,5 11,25/16,0	CHM-M-A47-TPPPPPT-1* CHM-M-A47-TPPPPPT-2**

Insertion tool: Part Number 121586-5080

On request: Telephony Spec./Hot Swap

+ Attention: Please consider the different pin lengths in the assembly drawing.

* Performance class I > 500 mating cycles ** Performance class II > 250 mating cycles

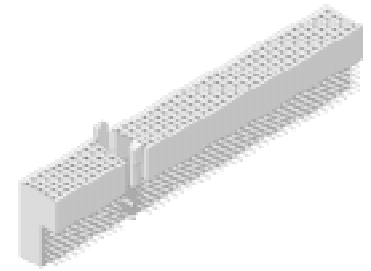

Female Connectors Type Compact PCI (J1+J2/J4+J5)

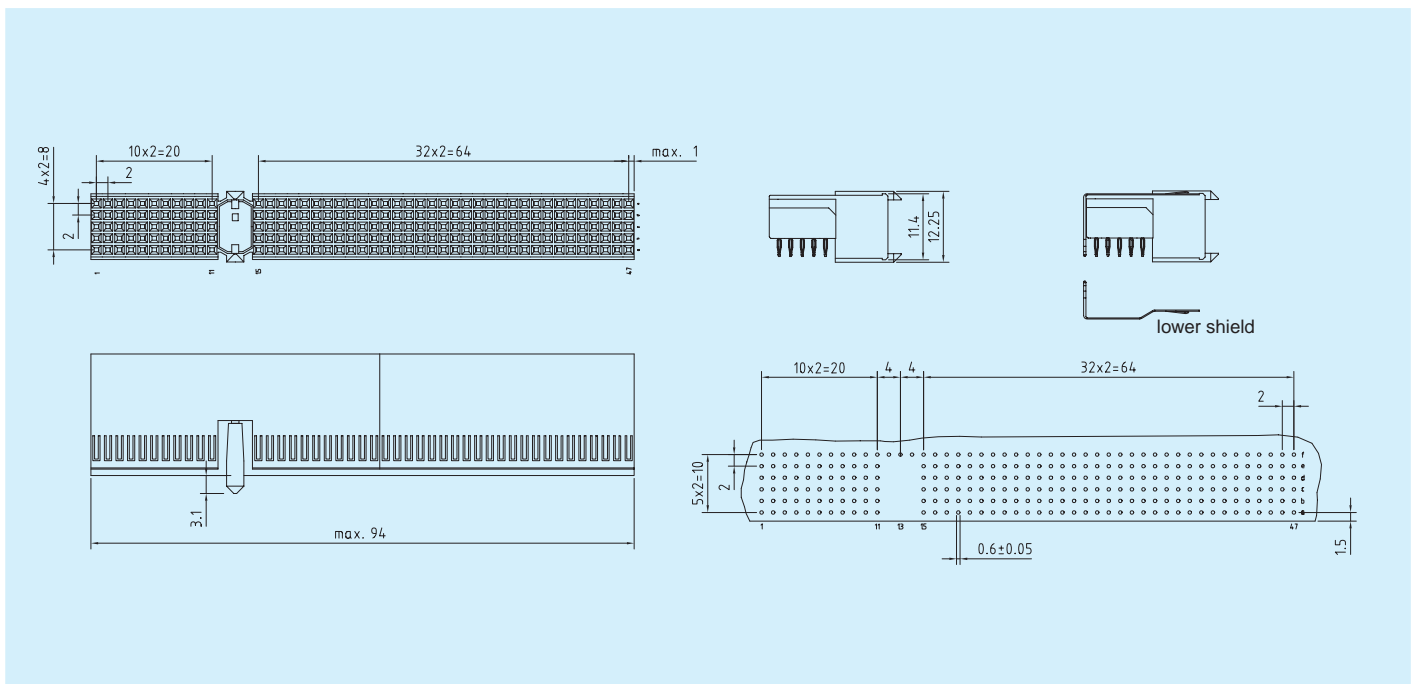

Type	No. of Positions	Part Numbers
connector without shielding	220	CHM-F-A47-P1-0-1*
		CHM-F-A47-P1-0-2**
connector with shielding	220	CHM-F-A47-P1-S-1*
		CHM-F-A47-P1-S-2**
lower shield		CHM120230-9000 and CHM120230-9002

* Performance class I > 500 mating cycles ** Performance class II > 250 mating cycles



Male Connectors Type D

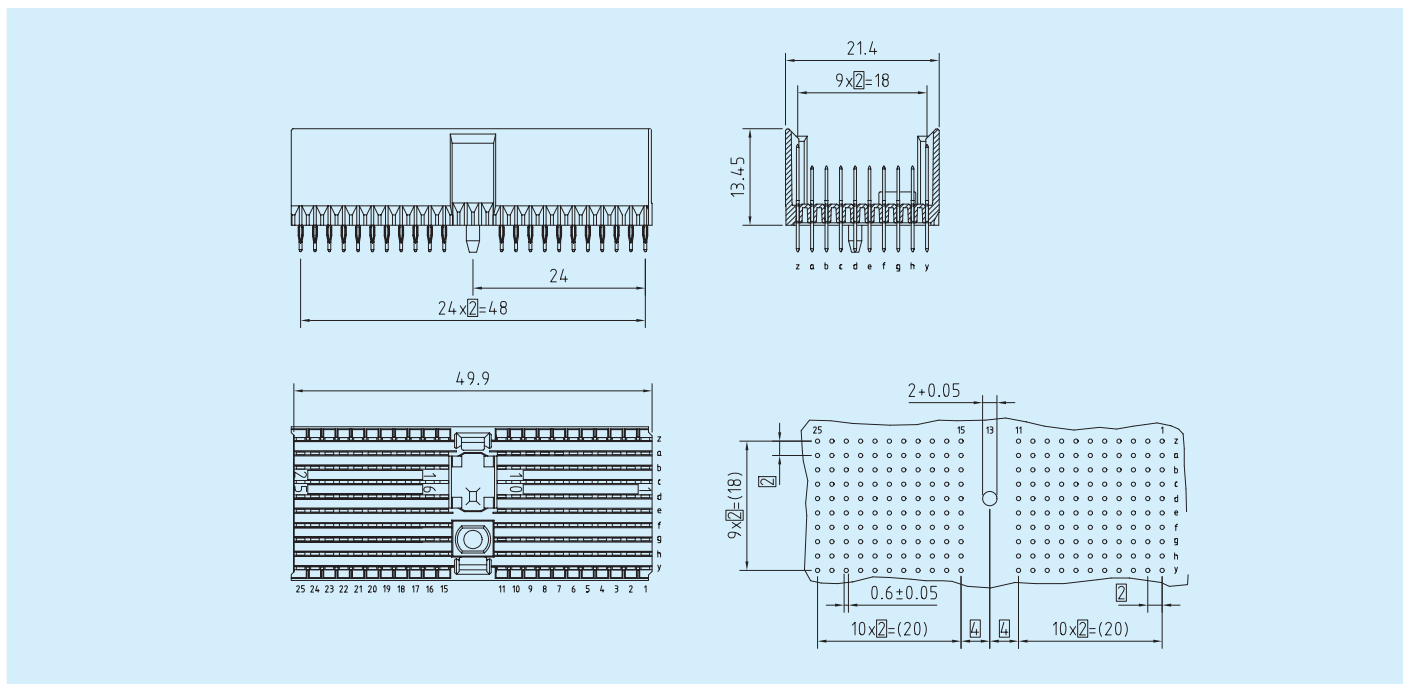

Assembly Drawing	No. of Positions	Row	Type	Pin length	Part Numbers
	176	z a b c d e f g h y	- A A A A A A A A -	-/- 8,25/3,7 8,25/3,7 8,25/3,7 8,25/3,7 8,25/3,7 8,25/3,7 8,25/3,7 8,25/3,7 -	CHM-M-D-0001-1 * CHM-M-D-0001-2**
		z a b c d e f g h y	C A A A A A A A A C	11,25/3,7 8,75/3,7 8,75/3,7 8,75/3,7 8,75/3,7 8,75/3,7 8,75/3,7 8,75/3,7 8,75/3,7 11,25/3,7	CHM-M-D-0002-1 * CHM-M-D-0002-2**

Insertion Tool: Part Number 121586-5082

* Performance class I > 500 mating cycles ** Performance class II > 250 mating cycles



Male Connectors Type E

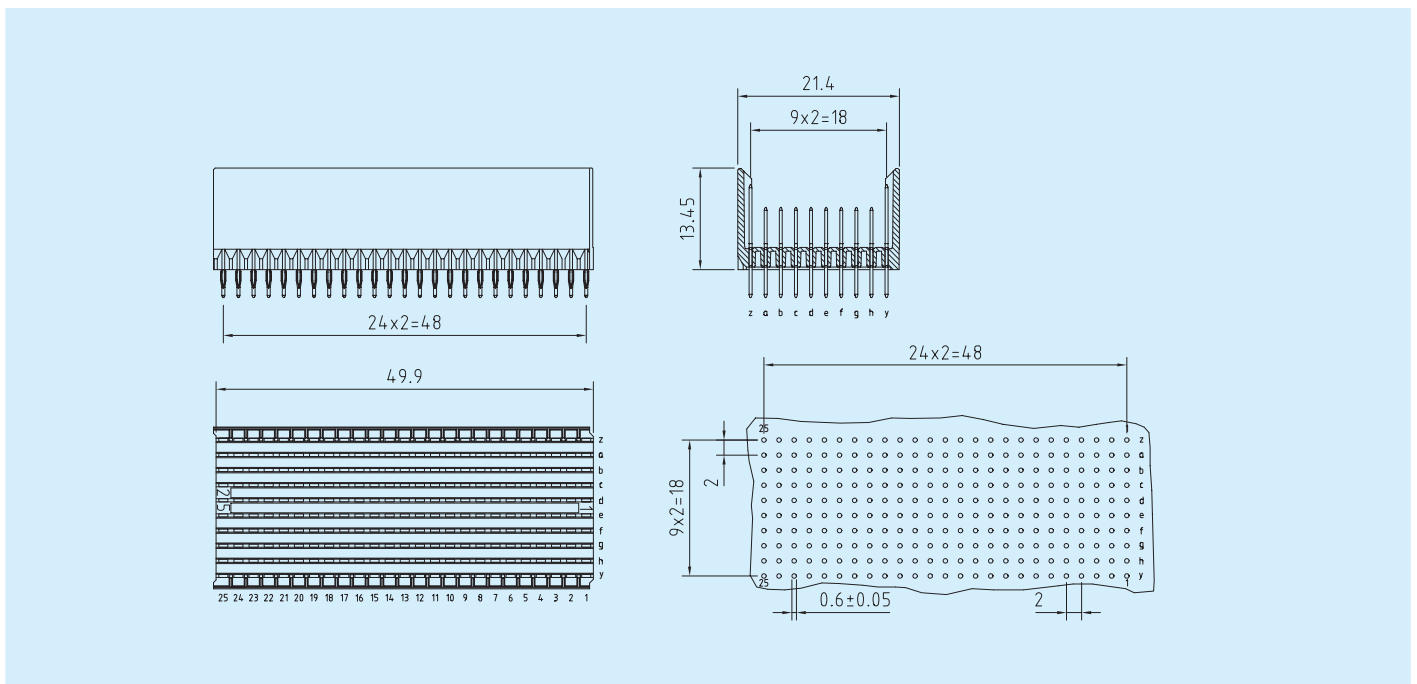

Assembly Drawing	No. of Positions	Row	Type	Pin length	Part Numbers
	200	z a b c d e f g h y	- A A A A A A A A -	-/- 8,25/3,7 8,25/3,7 8,25/3,7 8,25/3,7 8,25/3,7 8,25/3,7 8,25/3,7 8,25/3,7 -	CHM-M-E-0001-1 * CHM-M-E-0001-2**
	250	z a b c d e f g h y	C A A A A A A A A C	11,25/3,7 8,25/3,7 8,25/3,7 8,25/3,7 8,25/3,7 8,25/3,7 8,25/3,7 8,25/3,7 8,25/3,7 11,25/3,7	CHM-M-E-0002-1 * CHM-M-E-0002-2**

Insertion Tool: Part Number 121586-5086

* Performance class I > 500 mating cycles ** Performance class II > 250 mating cycles



Male Connectors Type L

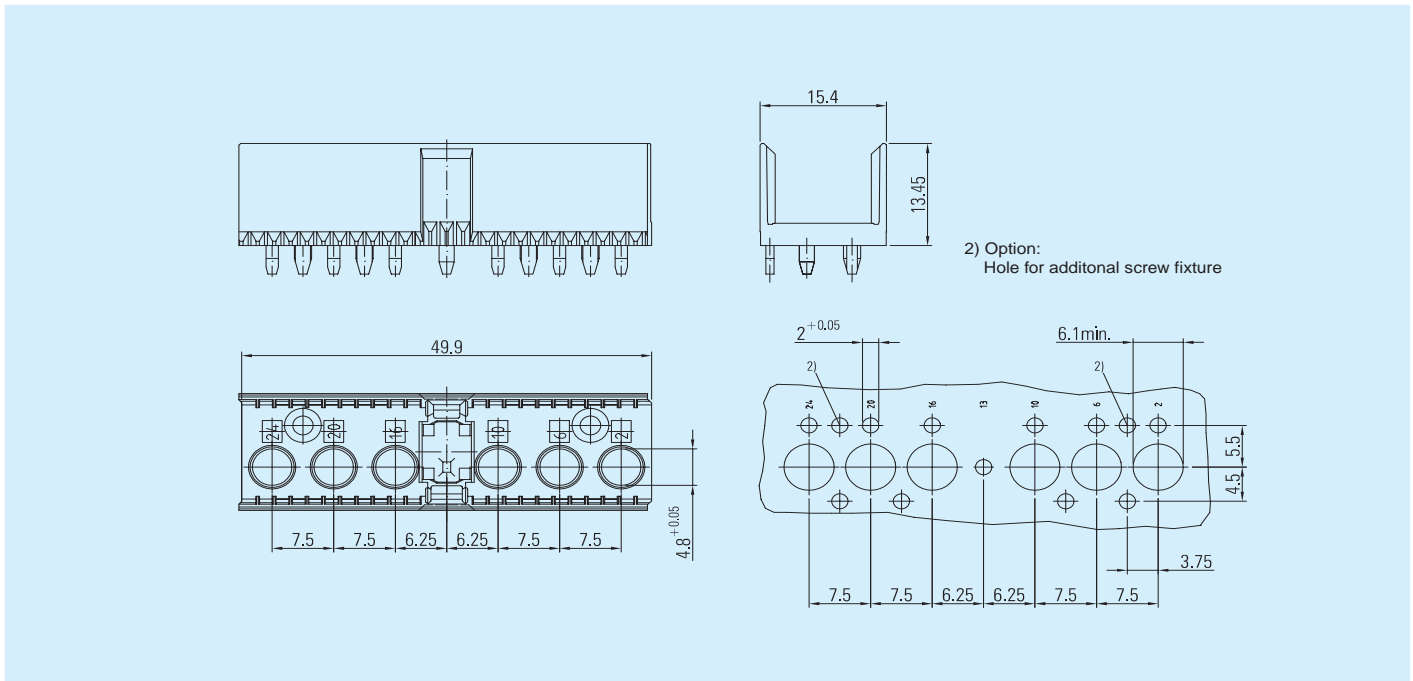

Assembly Drawing	No. of Positions	Row	Type	Pin length	Part Number
	6	-	-	-	CHM-M-L



Male Connectors Type M

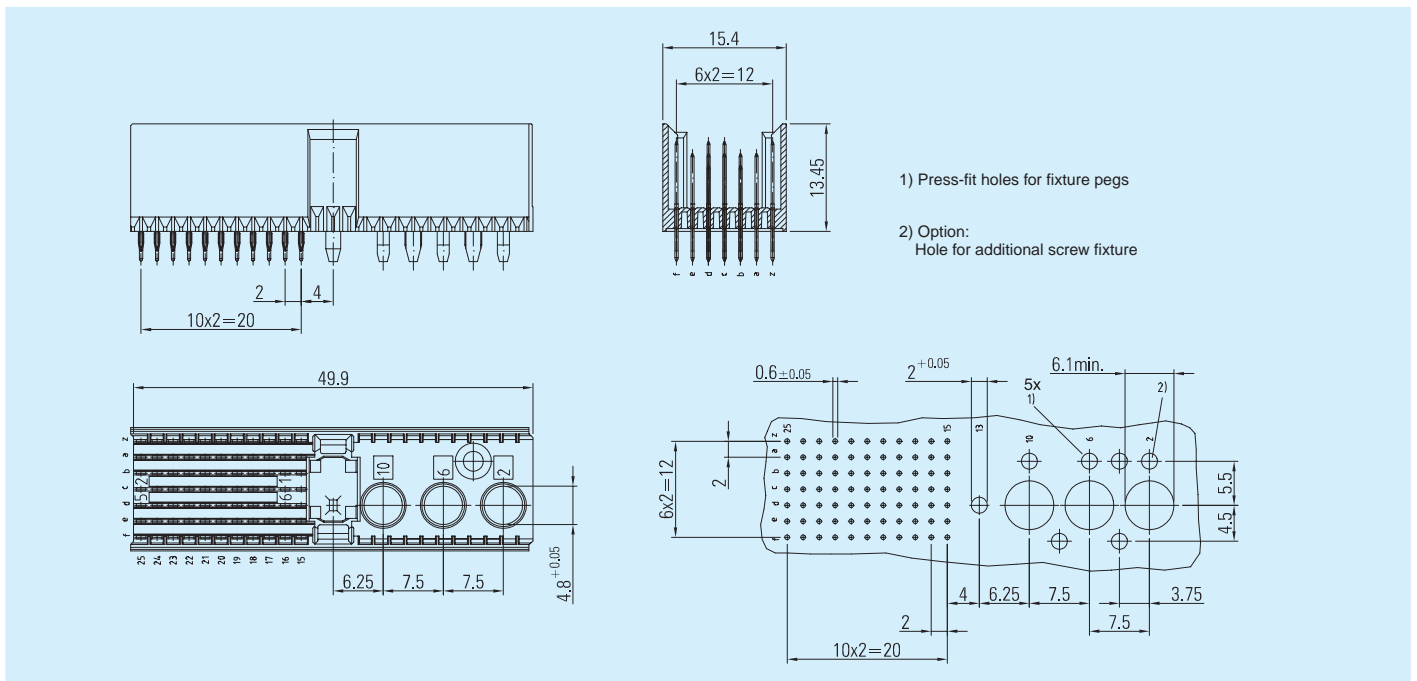

Assembly Drawing	No. of Positions	Row	Type	Pin length	Part Numbers
	55+3	z a b c d e f	- A A A A A -	-/- 8,25/3,7 8,25/3,7 8,25/3,7 8,25/3,7 8,25/3,7 -/-	CHM-M-M-OAAAAA0-1* CHM-M-M-OAAAAA0-2**
	77+3	z a b c d e f	C A A A A A C	11,25/3,7 8,25/3,7 8,25/3,7 8,25/3,7 8,25/3,7 8,25/3,7 11,25/3,7	CHM-M-M-CAAAAAC-1* CHM-M-M-CAAAAAC-2**

* Performance class I > 500 mating cycles ** Performance class II > 250 mating cycles



Male Connectors Type N

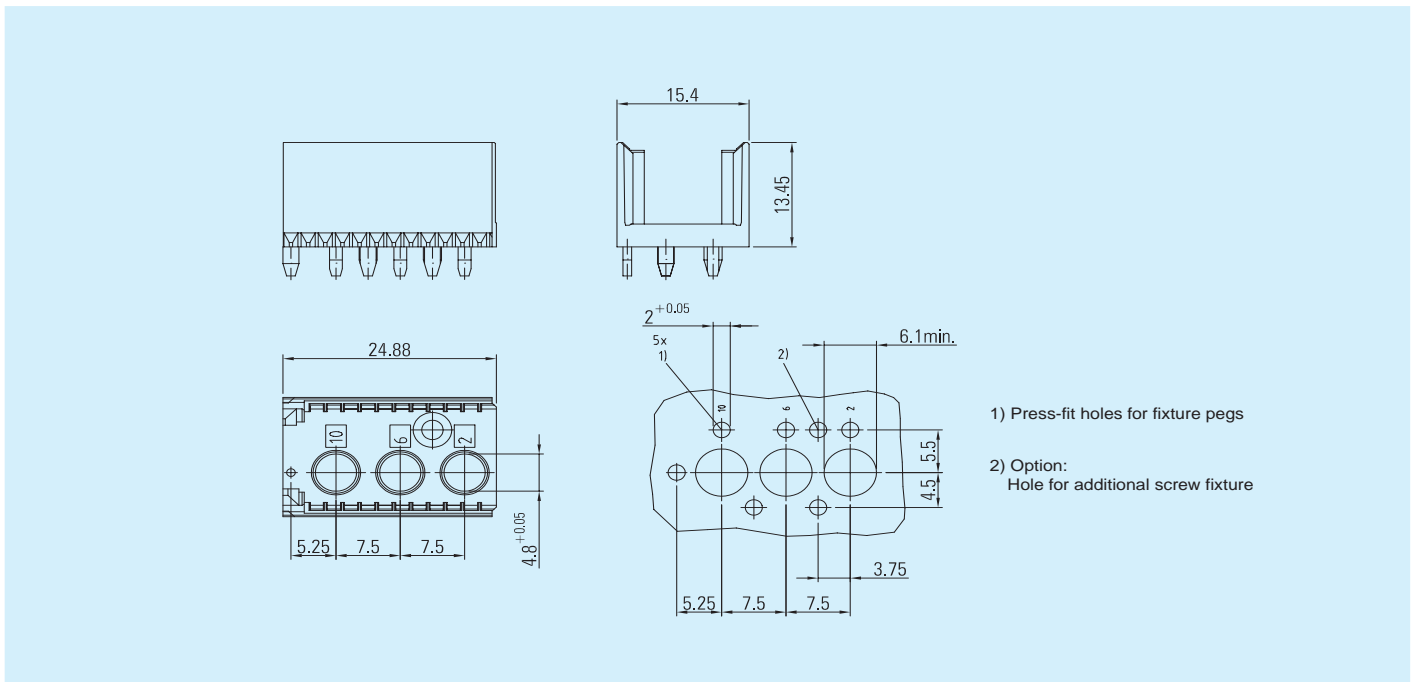

Assembly Drawing	No. of Positions	Row	Type	Pin length	Part Number
	3	-	-	-	CHM-M-N



Shrouds for Male Connectors Type A, B, B-22, B-19 and C

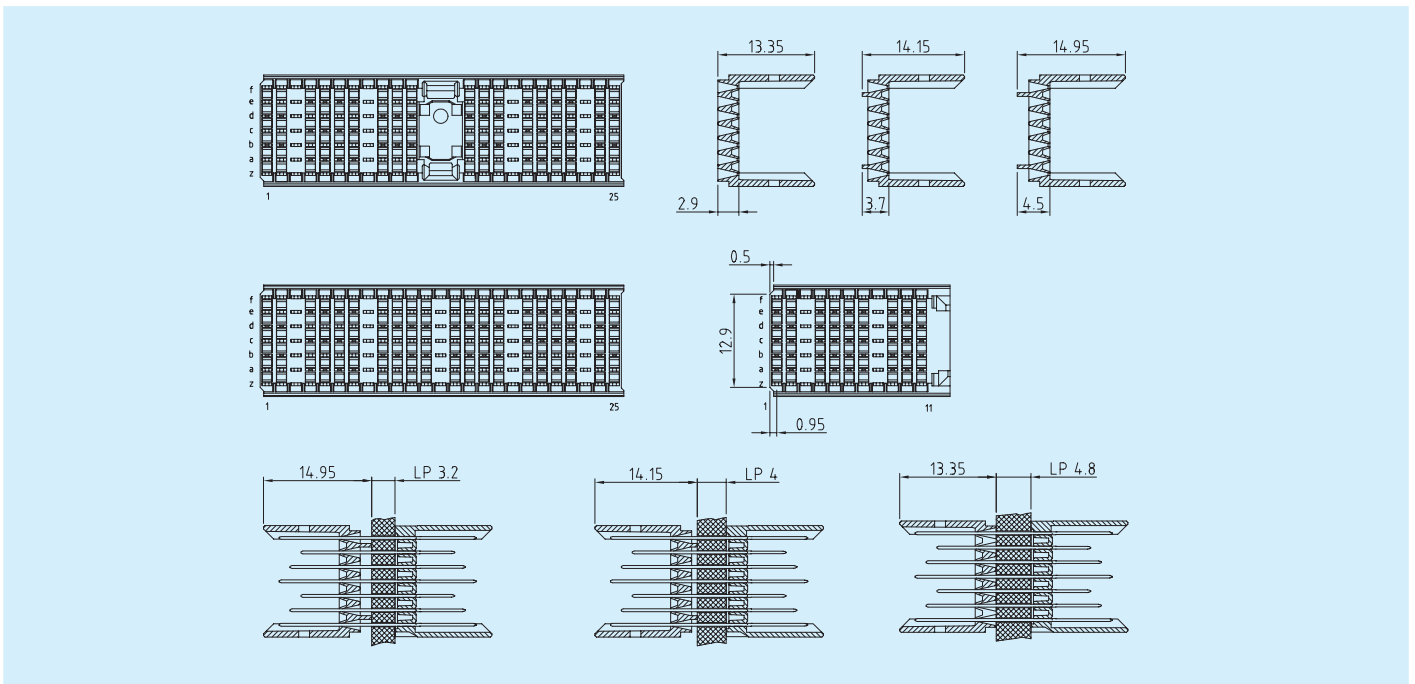

PCB thickness	3,2 – 4 mm	4,0 – 4,8 mm	> 4,8 mm
Shroud	14,95 mm	14,15 mm	13,35
Connector Type	Part Numbers		
A	CHM-S-A25-1	CHM-S-A25-2	CHM-S-A25-3
B	CHM-S-B25-1	CHM-S-B25-2	CHM-S-B25-3
B-22	CHM-S-B22-1	CHM-S-B22-2	CHM-S-B22-3
B-19	CHM-S-B19-1	CHM-S-B19-2	CHM-S-B19-3
C	CHM-S-C11-1	CHM-S-C11-2	CHM-S-C11-3

On request: other heights and special shrouds

Shrouds for Male Connectors Type AB

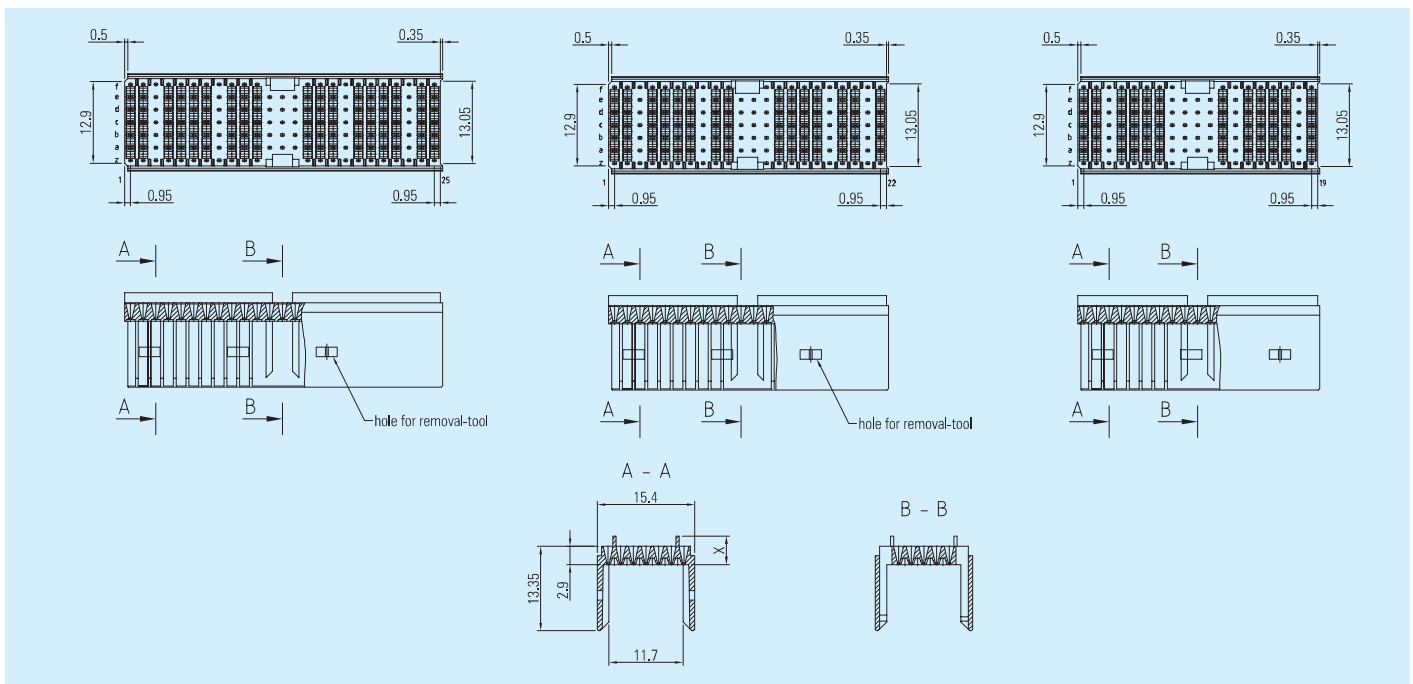

PCB thickness	3,2 – 4 mm	4,0 – 4,8 mm	> 4,8 mm
Shroud	14,95 mm	14,15 mm	13,35
Connector Type	Part Numbers		
AB-25	CHM-S-AB25-1	CHM-S-AB25-2	CHM-S-AB25-3
AB-22	CHM-S-AB22-1	CHM-S-AB22-2	CHM-S-AB22-3
AB-19	CHM-S-AB19-1	CHM-S-AB19-2	CHM-S-AB19-3

On request: other heights and special shrouds

Coding Devices

Male connectors

Coding key	Code No.	Colour	Part Number
	1236	Nut brown RAL 8011	CHM120230-1236
	1248	Strawberry red RAL 3018 Telephony Spec.	CHM120230-1248
	1356	Blue lilac RAL 4005	CHM120230-1356
	1567	Brillant blue RAL 5007 5,0 V C-PCI	CHM120230-1567
	2578	Reseda green RAL 6011	CHM120230-2578
	3456	Cadmium yellow RAL 1021 3,3 V C-PCI	CHM120230-3456
	3467	Slate grey RAL 7015	CHM120230-3467
	3478	Steel blue RAL 5011	CHM120230-3478
	3568	Pastel orange RAL 2003	CHM120230-3568
	4678	Ochre yellow RAL 1024	CHM120230-4678

Female connectors

Coding key	Code No.	Colour	Part Number
	4578	Nut brown RAL 8011	CHM120230-4578
	3567	Strawberry red RAL 3018 Telephony Spec.	CHM120230-3567
	2478	Blue lilac RAL 4005	CHM120230-2478
	2348	Brillant blue RAL 5007 5,0 V C-PCI	CHM120230-2348
	1346	Reseda green RAL 6011	CHM120230-1346
	1278	Cadmium yellow RAL 1021 3,3 V C-PCI	CHM120230-1278
	1258	Slate grey RAL 7015	CHM120230-1258
	1256	Steel blue RAL 5011	CHM120230-1256
	1247	Pastel orange RAL 2003	CHM120230-1247
	1235	Ochre yellow RAL 1024	CHM120230-1235

Insertion Tools

Male Connectors Type A, D

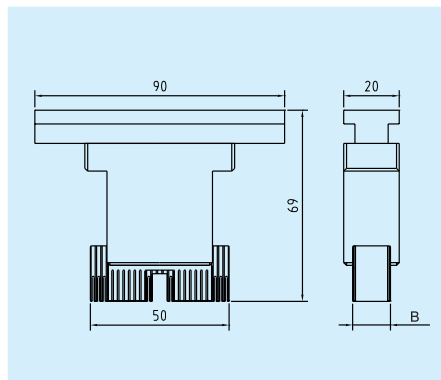
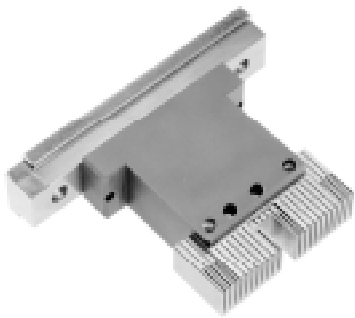

Type	Part Number	A/B (mm)
A	121586-5081	-/13,6
D	121586-5082	-/16

Male Connectors Type B, B-22, B-19, E

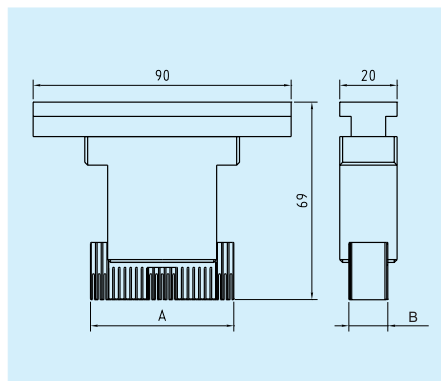
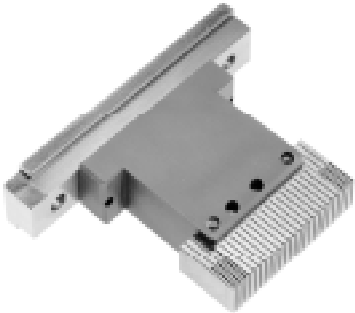

Type	Part Number	A/B (mm)
B	121586-5083	50/13,6
B-22	121586-5084	44/13,6
B-19	121586-5085	38/13,6
E	121586-5086	50/19,6

Male Connectors Type C

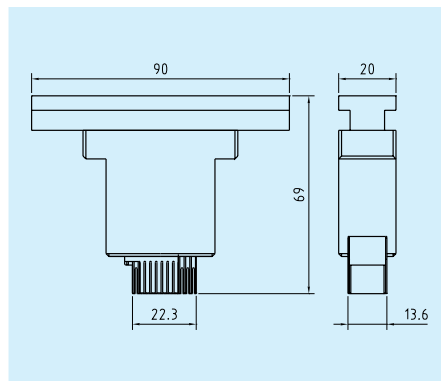

Type	Part Number	A/B (mm)
C	121586-5087	-

Insertion Tools

Male Connectors Type Compact PCI

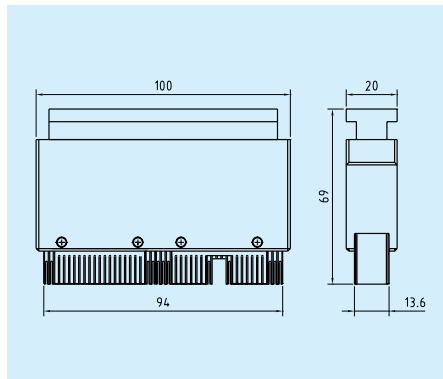

Type	Part Number	A/B (mm)
C-PCI	121586-5080	-

Male Connectors Flat Rock Tool

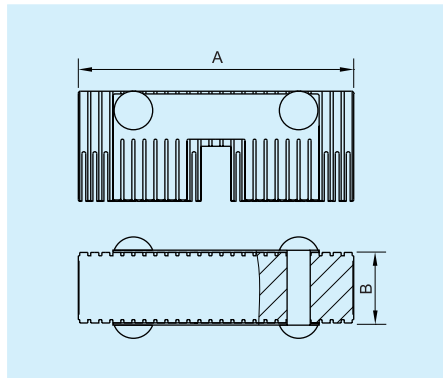
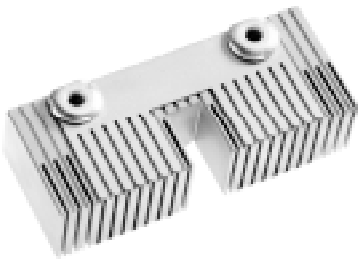

Type	Part Number	A/B (mm)
A	121586-5097	50/13,6
B	121586-5098	50/13,6
B-22	121586-5099	44/13,6
B-19	121586-5100	38/13,6
C	121586-5101	25/13,6
C-PCI	121586-5102	94/13,6
D	121586-5103	50/19,6
E	121586-5104	50/19,6

Female Connectors Flat Rock Pressfit Tool

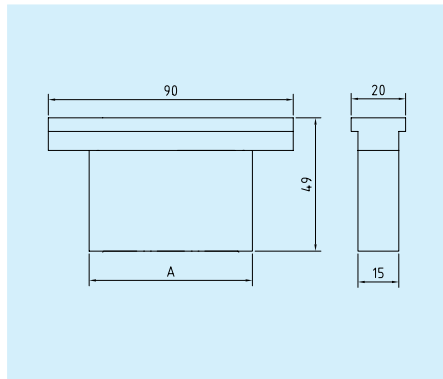

Type	Part Number	A/B (mm)
A, B, C	121586-5105	60/-
PCI	121586-5106	94/-

Support Tools

Male Connectors
Type A, Compact PCI, D

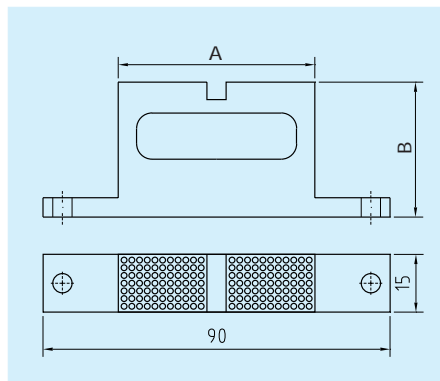
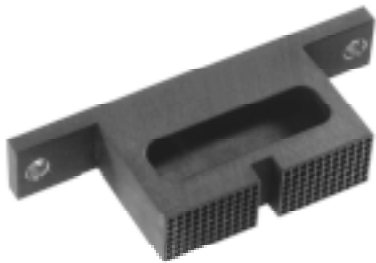

Type	Part Number	A/B (mm)
A	121586-5088	59/15
C-PCI	121586-5089	95/15
D	121586-5090	51/21

Male Connectors
Type B, B-22, B-19, C, E

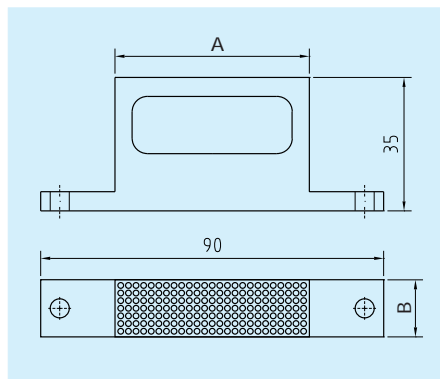
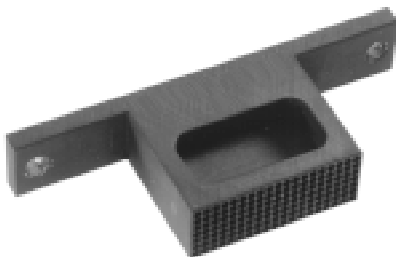

Type	Part Number	A/B (mm)
A	121586-5091	50/15
B-22	121586-5092	44/15
B-19	121586-5093	38/15
C	121586-5094	25/15
E	121586-5095	50/21

Support Block

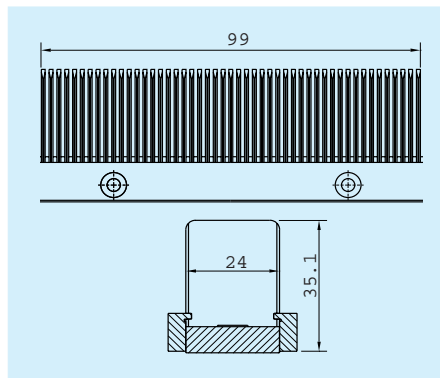

Type	Part Number	A/B (mm)
Univers	121586-5096	-

Mounting and Repair Set

Part Number 121586-5079

Shroud Stripping Tool

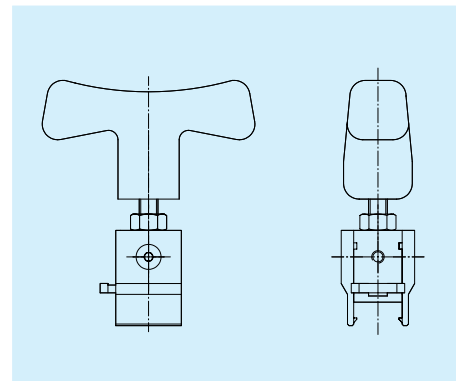

Single Pin Extraction Tool

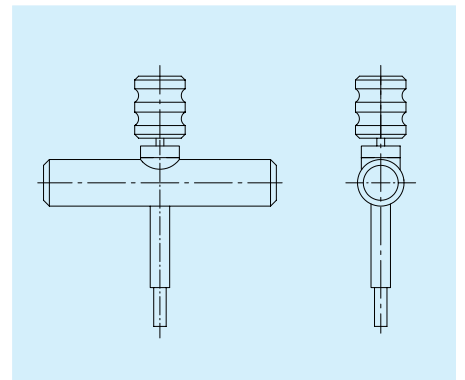

Coding Key Set

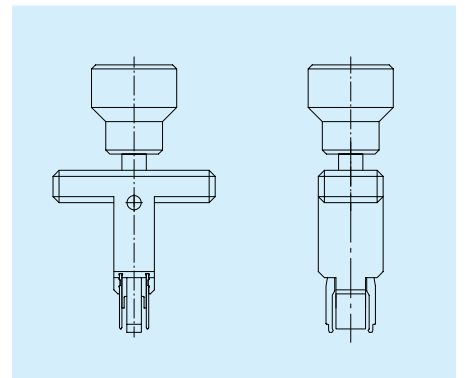

Connector Order Number Index

Order Number	Page	Order Number	Page	Order Number	Page
CHM120230-0	9	CHM-F-A25-P1-S-2	9	CHM-M-B19-CBBBBBC-2	14
CHM120230-1	9	CHM-F-A47-P1-0-1	19	CHM-M-B19-TPPPPT-1	14
CHM120230-1235	27	CHM-F-A47-P1-0-2	19	CHM-M-B19-TPPPPT-2	14
CHM120230-1236	27	CHM-F-A47-P1-S-1	19	CHM-M-B22-CAAAAAC-1	12
CHM120230-1247	27	CHM-F-A47-P1-S-2	19	CHM-M-B22-CAAAAAC-2	12
CHM120230-1248	27	CHM-F-B19-P1-0-1	15	CHM-M-B22-CBBBBBC-1	12
CHM120230-1256	27	CHM-F-B19-P1-0-2	15	CHM-M-B22-CBBBBBC-2	12
CHM120230-1258	27	CHM-F-B19-P1-S-1	15	CHM-M-B22-TPPPPT-1	12
CHM120230-1278	27	CHM-F-B19-P1-S-2	15	CHM-M-B22-TPPPPT-2	12
CHM120230-1346	27	CHM-F-B22-P1-0-1	13	CHM-M-B25-0AAAAA0-1	10
CHM120230-1356	27	CHM-F-B22-P1-0-2	13	CHM-M-B25-0AAAAA0-2	10
CHM120230-1567	27	CHM-F-B22-P1-S-1	13	CHM-M-B25-0BBBBB0-1	10
CHM120230-2348	27	CHM-F-B22-P1-S-2	13	CHM-M-B25-0BBBBB0-2	10
CHM120230-2478	27	CHM-F-B25-P1-0-1	11	CHM-M-B25-CAAAAAC-1	10
CHM120230-2578	27	CHM-F-B25-P1-0-2	11	CHM-M-B25-CAAAAAC-2	10
CHM120230-3456	27	CHM-F-B25-P1-S-1	11	CHM-M-B25-CBBBBBC-1	10
CHM120230-3467	27	CHM-F-B25-P1-S-2	11	CHM-M-B25-CBBBBBC-2	10
CHM120230-3478	27	CHM-F-C11-P1-0-1	17	CHM-M-C11-0AAAAA0-1	16
CHM120230-3567	27	CHM-F-C11-P1-0-2	17	CHM-M-C11-0AAAAA0-2	16
CHM120230-3568	27	CHM-F-C11-P1-S-1	17	CHM-M-C11-0BBBBB0-1	16
CHM120230-4578	27	CHM-F-C11-P1-S-2	17	CHM-M-C11-0BBBBB0-2	16
CHM120230-4678	27	CHM-M-A25-0AAAAA0-1	8	CHM-M-C11-CAAAAAC-1	16
CHM120230-500	8	CHM-M-A25-0AAAAA0-2	8	CHM-M-C11-CAAAAAC-2	16
CHM120230-501	8	CHM-M-A25-0BBBBB0-1	8	CHM-M-C11-CBBBBBC-1	16
CHM120230-502	8	CHM-M-A25-0BBBBB0-2	8	CHM-M-C11-CBBBBBC-2	16
CHM120230-503	8	CHM-M-A25-CAAAAAC-1	8	CHM-M-D-0001-1	20
CHM120230-504	8	CHM-M-A25-CAAAAAC-2	8	CHM-M-D-0001-2	20
CHM120230-505	8	CHM-M-A25-CBBBBBC-1	8	CHM-M-D-0002-1	20
CHM120230-506	12	CHM-M-A25-CBBBBBC-2	8	CHM-M-D-0002-2	20
CHM120230-507	12	CHM-M-A25-TPPPPT-1	8	CHM-M-E-0001-1	21
CHM120230-508	18	CHM-M-A25-TPPPPT-2	8	CHM-M-E-0001-2	21
CHM120230-509	18	CHM-M-A47-CAAAAAC-1	18	CHM-M-E-0002-1	21
CHM120230-9000	9/19	CHM-M-A47-CAAAAAC-2	18	CHM-M-E-0002-2	21
CHM120230-9001	11	CHM-M-A47-TPPPPT-1	18	CHM-M-L	22
CHM120230-9002	9/19	CHM-M-A47-TPPPPT-2	18	CHM-M-M-0AAAAA0-1	23
CHM120230-9003	15	CHM-M-B19-0AAAAA0-1	14	CHM-M-M-0AAAAA0-2	23
CHM120230-9006	17	CHM-M-B19-0AAAAA0-2	14	CHM-M-M-CAAAAAC-1	23
CHM-F-A25-P1-0-1	9	CHM-M-B19-CAAAAAC-1	14	CHM-M-M-CAAAAAC-2	23
CHM-F-A25-P1-0-2	9	CHM-M-B19-CAAAAAC-2	14	CHM-M-N	24
CHM-F-A25-P1-S-1	9	CHM-M-B19-CBBBBBC-1	14	CHM-S-A25-1	25

Connector Order Number Index

Order Number	Page
CHM-S-A25-2	25
CHM-S-A25-3	25
CHM-S-AB19-1	26
CHM-S-AB19-2	26
CHM-S-AB19-3	26
CHM-S-AB22-1	26
CHM-S-AB22-2	26
CHM-S-AB22-3	26
CHM-S-AB25-1	26
CHM-S-AB25-2	26
CHM-S-AB25-3	26
CHM-S-B19-1	25
CHM-S-B19-2	25
CHM-S-B19-3	25
CHM-S-B22-1	25
CHM-S-B22-2	25
CHM-S-B22-3	25
CHM-S-B25-1	25
CHM-S-B25-2	25
CHM-S-B25-3	25
CHM-S-C11-1	25
CHM-S-C11-2	25
CHM-S-C11-3	25

Tool Order Number Index

Order Number	Page
121586-5080	29
121586-5081	28
121586-5082	28
121586-5083	28
121586-5084	28
121586-5085	28
121586-5086	28
121586-5087	28
121586-5088	30
121586-5089	30
121586-5090	30
121586-5091	30
121586-5092	30
121586-5093	30
121586-5094	30
121586-5095	30
121586-5096	30
121586-5097	29
121586-5098	29
121586-5099	29
121586-5100	29
121586-5101	29
121586-5102	29

Order Number	Page
121586-5103	29
121586-5104	29
121586-5105	29
121586-5106	29

Product Safety Information

THIS NOTE SHOULD BE READ IN CONJUNCTION WITH THE PRODUCT DATA SHEET/CATALOGUE. FAILURE TO OBSERVE THE ADVICE IN THIS INFORMATION SHEET AND THE OPERATING CONDITIONS SPECIFIED IN THE PRODUCT DATA SHEET/CATALOGUE COULD RESULT IN HAZARDOUS SITUATIONS.

1. MATERIAL CONTENT AND PHYSICAL FORM

Electrical connectors do not usually contain hazardous materials. They contain conducting and non-conducting materials and can be divided into two groups.

- a) Printed circuit types and low cost audio types which employ all plastic insulators and casings.
- b) Rugged, Fire Barrier and High Reliability types with metal casings and either natural rubber, synthetic rubber, plastic or glass insulating materials.

Contact materials vary with type of connector and also application and are usually manufactured from either copper, copper alloys, nickel, alumel, chromel or steel. In special applications, other alloys may be specified.

2. FIRE CHARACTERISTICS AND ELECTRIC SHOCK HAZARD

There is no fire hazard when the connector is correctly wired and used within the specified parameters. Incorrect wiring or assembly of the connector or careless use of metal tools or conductive fluids, or transit damage to any of the component parts may cause electric shock or burns. Live circuits must not be broken by separating mated connectors as this may cause arcing, ionisation and burning.

Heat dissipation is greater at maximum resistance in a circuit. Hot spots may occur when resistance is raised locally by damage, e.g. cracked or deformed contacts, broken strands of wire. Local overheating may also result from the use of the incorrect application tools or from poor quality soldering or slack screw terminals. Overheating may occur if the ratings in the Product Data Sheet/Catalogue are exceeded and can cause breakdown of insulation and hence electric shock.

If heating is allowed to continue it intensifies by further increasing the local resistance through loss of temper of spring contacts, formation of oxide film on contacts and wires, and leakage currents through carbonisation of insulation and tracking paths. Fire can then result in the presence of combustible materials and this may release noxious fumes. Overheating may not be visually apparent. Burns may result from touching overheated components.

3. HANDLING

Care must be taken to avoid damage to any component parts of electrical connectors during installation and use. Although there are normally no sharp edges, care must be taken when handling certain components to avoid injury to fingers.

Electrical connectors may be damaged in transit to the customers, and damage may result in creation of hazards. Products should therefore be examined prior to installation/use and rejected if found to be damaged.

4. DISPOSAL

Incineration of certain materials may release noxious or even toxic fumes.

5. APPLICATION

Connectors with exposed contacts should not be selected for use on the current supply side of an electrical circuit, because an electric shock could result from touching exposed contacts on an unmated connector. Voltages in excess of 30 V ac or 42.5 V dc are potentially hazardous and care should be taken to ensure that such voltages can not be transmitted in any way to exposed metal parts of the connector body. The connector and wiring should be checked, before making live, to have no damage to metal parts or insulators, no solder blobs, loose strands, conducting lubricants, swarf, or any other undesired conducting particles. Insulation resistance should be checked to make certain that no low resistance joints or spurious conducting path are existing between contacts and exposed metal parts of the connector body. Further the contact resistance of the connectors should be measured within the electrical circuit in order to identify high resistances which result in excessive connector heating.

Always use the correct application tools as specified in the Data Sheet/Catalogue.

Do not permit untrained personnel to wire, assemble or tamper with connectors.

For operation voltage please see appropriate national regulations.

IMPORTANT GENERAL INFORMATION.

1. Air and creepage paths/Operating voltage

The admissible operating voltages depend on the individual applications and the valid national and other applicable safety regulations.

For this reason the air and creepage path data are only reference values. Observe reduction of air and creepage paths due to PC board and/or harnessing.

2. Temperature

All information given are temperature limits. The operation temperature depends on the individual application.

3. Other important information

Cannon continuously endeavours to improve their products. Therefore, Cannon products may deviate from the description, technical data and shape as shown in this catalogue and data sheets.

4. Harnessing and Assembly Instructions

If applicable, our special harnessing and/or assembly instruction has to be adhered to. This is provided at request.

ITT Cannon manufactures the highest quality products available in the marketplace; however these products are intended to be used in accordance with the specifications in this catalog. Any use or application that deviates from stated operating specifications is not recommended and may be unsafe. No information and data contained in this catalog shall be construed to create any liability on the part of Cannon. Any new issue of this catalog shall automatically invalidate and supersede any and all previous issues. **A limited warranty applies to Cannon products. Except for obligations assumed by Cannon under this warranty, Cannon shall not be liable for any loss, damage, cost of repairs, incidental or consequential damages of any kind, whether or not based on express or implied warranty, contract, negligence or strict liability arising in connection with the design, manufacture, sale, use or repair of the products.** Product availability, prices and delivery dates are exclusively subject to our respective order confirmation form; the same applies to orders based on development samples delivered. This catalog is not be construed as an offer. It is intended merely as an invitation to make an offer. By this publication, Cannon does not assume responsibility or any liability for any patent infringements or other rights of third parties which may result from its use. Reprinting this catalog is generally permitted, indicating the source. However, Cannon's prior consent must be obtained in all cases.

Cannon is a trademark of ITT Industries, Inc

Fax request

Company _____	Phone Number _____ / _____
First Name _____ Last Name _____	Fax Number _____ / _____
Adress _____	E-Mail _____
Adress _____	Signature _____

Please quote me for pieces.

Please send me sample pieces.

Front view

Modul A

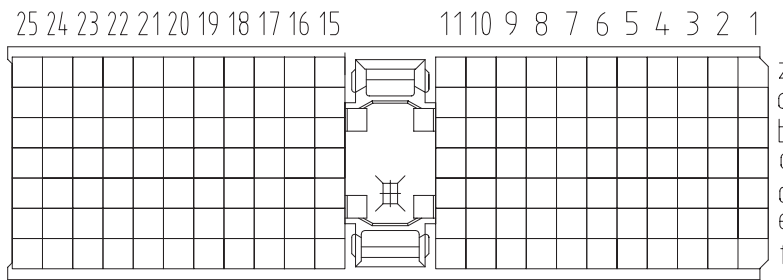

B25 B22 B19 Please mark by cross Modul B

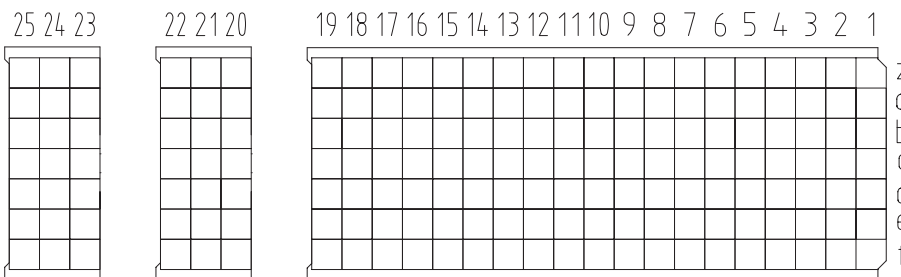

Assembly reference:

In order to be able to load the connectors economically we recommend a serial determination of the contact length. If only position 1 of a line is indicated, the entire line is loaded with this contact length. Exceptions can be registered at the respective position.

Surface:

Quality level 2 acc. to IEC 1076-4-101.
Au over PdNi over Ni.

Modul C

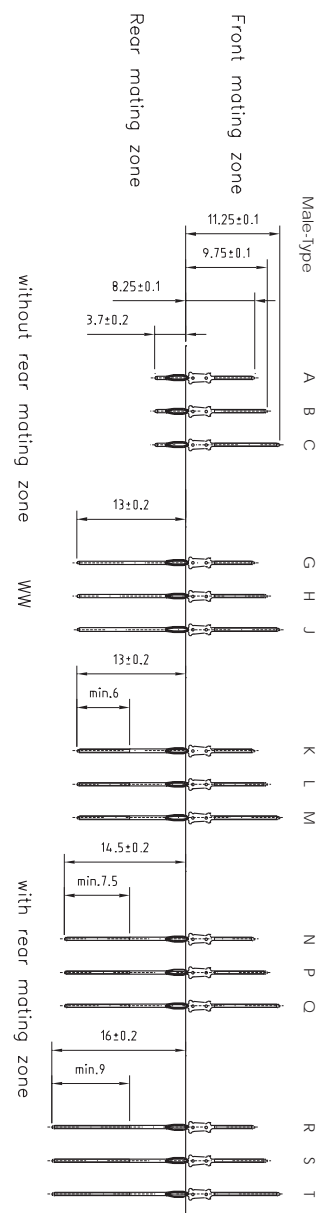
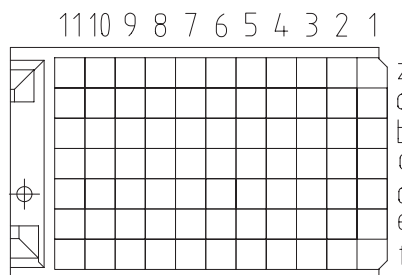

Cannon Worldwide Facilities

Austria

Afrikanergasse 3
1020 Vienna
FAX: (1) 2160948 PH: (1) 2160947

Benelux

Rue Col. Bourg Str. 105A
1140 Brussels, Belgium
FAX: (02) 7269201 PH: (02) 726 75 94
NL
FAX: 31.35.691.8796 PH: 31.35.691.6855

China

No. 24, 2 Block
Taohuawu New District
Zhenjiang, Jiangsu
P.R.C.
FAX: 86 511 4428616 PH: 86 511 443 3399

Denmark

Park Allé 287 A
2605 Brøndby
FAX: 43 43 58 58 PH: 43 45 52 88

Finland

Virkatie 1
1510 Vantaa
FAX:+358 9 70039188 PH: +358 9 70039180

France

2, Ave Sablons Bouillants, B.P. 133
77109 Meaux
FAX: (1) 64 33 16 82 PH: (1) 60 24 51 51

Germany

Postfach 11 20, 71365 Weinstadt
Cannonstrasse 1, 71384 Weinstadt
FAX: (07151) 699217 PH: (07151) 699-0

Hong Kong

906 New World Office Building
West Wing, 20 Salisbury Road
Tsim Sha Tsui, Kowloon
FAX: (852) 2369-5651 PH: (852) 2732-2720

Italy

Via Panzeri 10
20123 Milano
FAX: (02) 8372036 PH: (02) 581801

Japan

5362-1, 5-chome, Hibarigaoka
Zama-shi, Kanagawa 228
FAX: 0462-57-1680 PH: 0462-57-2010

Korea

620, Changkang Bldg.
#22, Dohwa-dong, Mapo-ku
Seoul
FAX: (02) 717 7330 PH: (02) 702 7111

Spain

Edificio Italia 1a planta
Parque Empresarial San Fernando
San Fernando de Henares
28831 Madrid
FAX: (34) 1 656 15 83 PH: (34) 1 656 03 11

Sweden

Norr Mälarstrand 64
Jaktvarvet 1
11235 Stockholm
FAX: (46) 8 650 0072 PH: (46) 8 650 0071

Switzerland

Herzogenmühle 18
8304 Wallisellen
FAX: (01) 830-3104 PH: (01) 830-3888, 830-3613

United Kingdom

Jays Close, Viabes Estate
Basingstoke Hampshire RG22 4BA
FAX: (01256) 323356 PH: (01256) 311200

United States

666 E. Dyer Road
Santa Ana, CA 92705-5612
FAX: 714.628.2142 PH: 714.557.4700

INTERNET

<http://www.ittcannon.com>

Cannon



ITT Industries
Engineered for life