

Preliminary

22-24.5GHz RX Multifunction

GaAs Monolithic Microwave IC In QFN package

Description

The CHR2411 is a monolithic multifunction in K-Band which integrates a Low Noise Amplifier and a mixer providing an IF signal from DC to 1 MHz. All the active devices are self biased on chip.

The circuit is manufactured with a standard GaAs HEMT process : 0.25µm gate length, via holes through the substrate, air bridges and electron beam gate lithography.

The chip is delivered in a 24 Leads RoHS compliant QFN4x4 package.

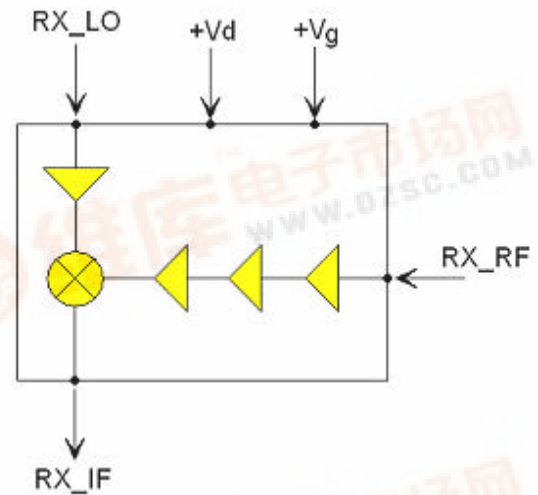

Multifunction block diagram

Main Features

- Typical Noise figure : 7 dB
- Stable gain vs temperature 23 ± 2.5 dB
- Single supply Voltage: +5V
- Devices self biased on chip
- Standard SMD package : QFN 24L 4x4



Plastic package

Main Characteristics

Symbol	Parameters	Min	Typ	Max	Unit
RX_RF	Frequency range	22		24.5	GHz
	Conversion Gain	19	23	27	dB
	SSB Noise figure (IF=1MHz)		7		dB
RX_LO / RX_RF	Input / Output Return Loss	8	15		dB

ESD Protection : Electrostatic discharge sensitive device. Observe handling precautions !

Ref. : DSCHR2411QDG6174 - 23 Jun 06 1/8

Specifications subject to change without notice

United Monolithic Semiconductors S.A.S.

Route Départementale 128 - B.P.46 - 91401 Orsay Cedex France

Tel. : +33 (0)1 69 33 03 08 - Fax : +33 (0)1 69 33 03 09



*Preliminary***Electrical Characteristics****Full temperature range**

Symbol/Pins	Parameters	Min	Typ	Max	Unit
RX_RF	Frequency range	22		24.5	GHz
RX_LO	Frequency range	22		24.5	GHz
RX_IF	Frequency range	DC		1	MHz
RX_RF	Return Loss	8	15		dB
RX_LO	Return Loss	8	15		dB
RX_IF	IF Load impedance		50		Ohms
PLO	LO Drive Power	0	5		dBm
	Conversion Gain	19	23		dB
	Gain variation over Temperature		± 2.5		dB
	SSB Noise figure (IF=1MHz)		7		dB
	Input Power at 1 dB Gain Compression @24GHz		-21		dBm
	Input IP3 @24GHz		-12		dBm
	LO to RF Isolation		-45	-30	dB
+Vg, +Vd	Supply Voltage		5		V
	Supply Current		60	80	mA
Top	Operating temperature range(3)	-40	25	100	°C

Remark :

These performance has been obtained with the chip in QFN package mounted on the recommended boards (ref. 95541 & 95581) described in this document. These performance are highly dependent on this environment.

Absolute Maximum Ratings (1)

Symbol	Parameters	Values	Unit
+Vg, +Vd	Maximum positive supply voltage	6	V
+I	Maximum positive supply current	90	mA
PLO	Maximum peak input power overdrive	8	dBm
PRF	Maximum peak input power overdrive	-12	dBm
Top	Operating temperature range (2)	-40 to +100	°C
Tstg	Storage temperature range	-55 to +125	°C

(1) Operation of this device above any one of these parameters may cause permanent damage. Duration < 1s

(2) Temperature of the back side of the QFN. Thermal resistance RTh= 155°C/W

Typical QFN measurements on board 95541 (QFN plan)

Preliminary

Conversion Gain vs Frequency
 PLO= 0dBm

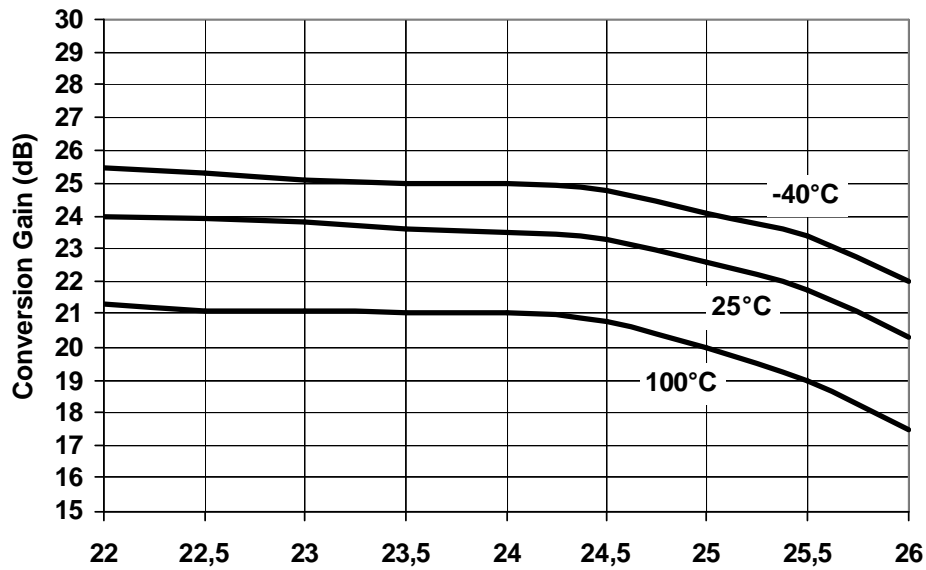

Conversion gain vs RF Input Power
 PLO= 0dBm FLO=24.25GHz

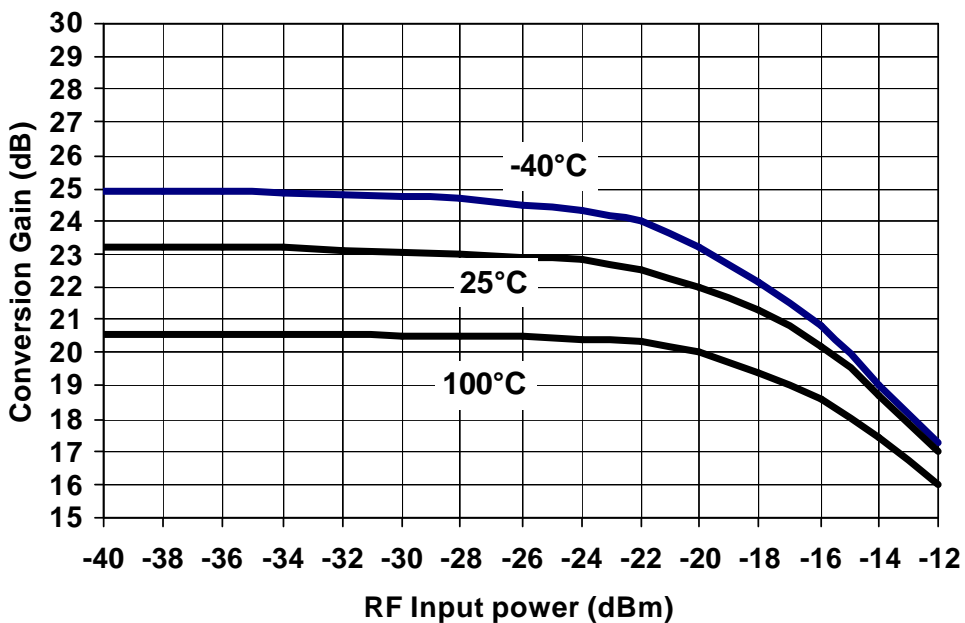

QFN Outline

Preliminary

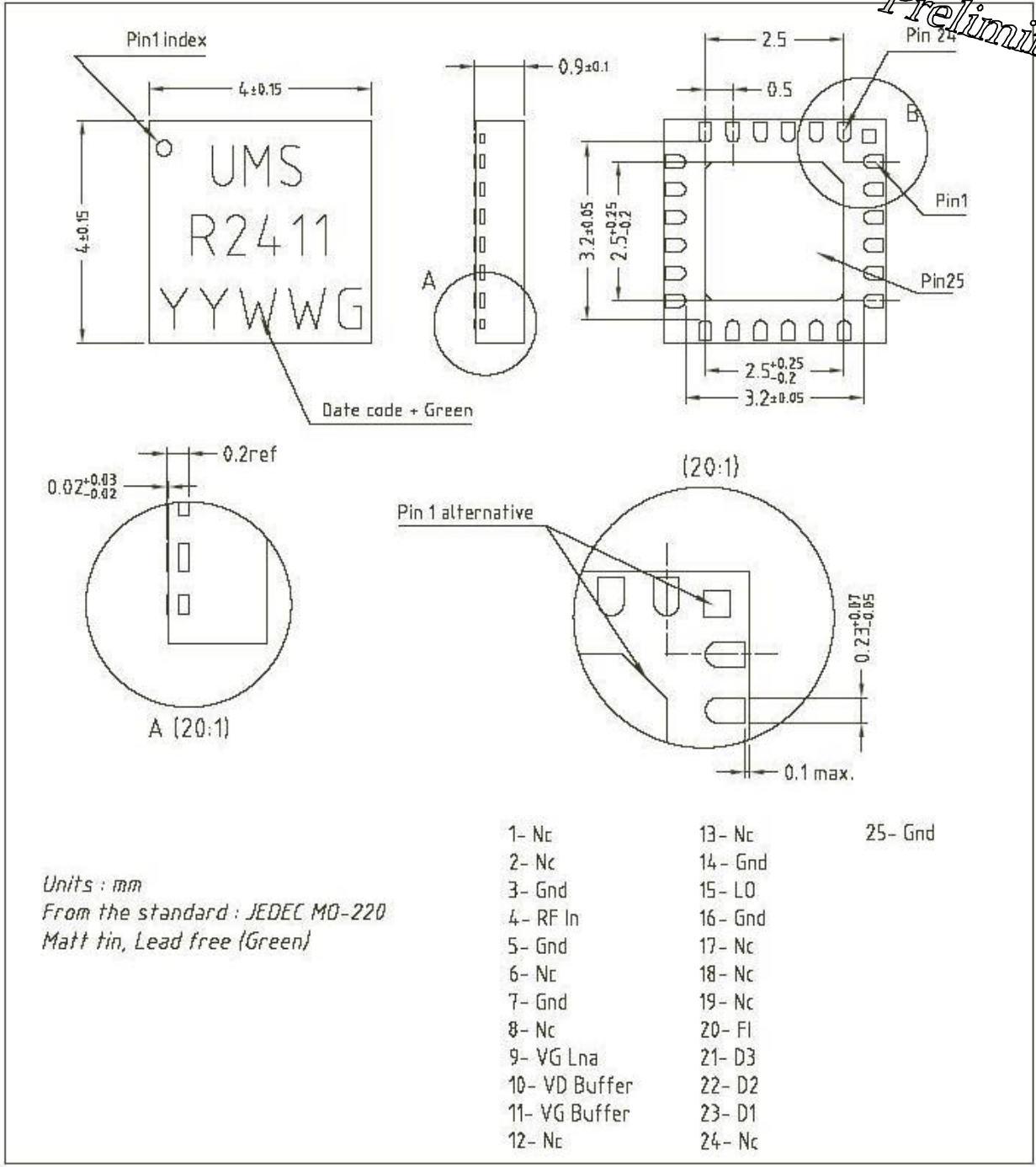

Units : mm
 From the standard : JEDEC MO-220
 Matt tin, Lead free (Green)

- | | | |
|---------------|---------|---------|
| 1- Nc | 13- Nc | 25- Gnd |
| 2- Nc | 14- Gnd | |
| 3- Gnd | 15- LO | |
| 4- RF In | 16- Gnd | |
| 5- Gnd | 17- Nc | |
| 6- Nc | 18- Nc | |
| 7- Gnd | 19- Nc | |
| 8- Nc | 20- FI | |
| 9- VG Lna | 21- D3 | |
| 10- VD Buffer | 22- D2 | |
| 11- VG Buffer | 23- D1 | |
| 12- Nc | 24- Nc | |

QFN Pin-out description

Preliminary

Pin number	Pin name	Symbol Name	Description
4	RfIn	RX_IN	RF Input port
15	LO	RX_LO	LO Input port
20	FI	RX_IF	IF Output port
23, 22, 21, 10	D1, D2, D3, VD Buffer	+Vd	Positive Drain supply voltage
9,11	VGLna, VG Buffer	+Vg	Positive Gate supply voltage
3, 5, 7, 14, 16, 25	GND		Ground
1, 2, 6, 8, 12, 13, 17, 18, 19, 24	Nc		Not connected

External Components and bias configuration (recommended)

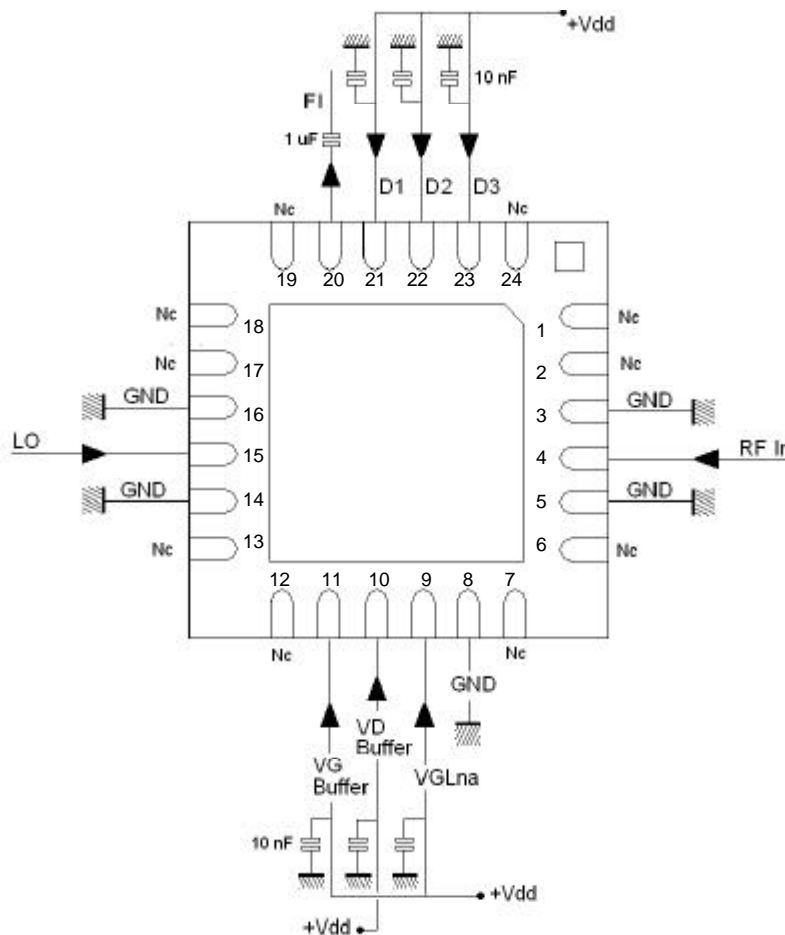

Recommended Test Fixture (Ref. 95541) for measurements over Temperature Range

Preliminary

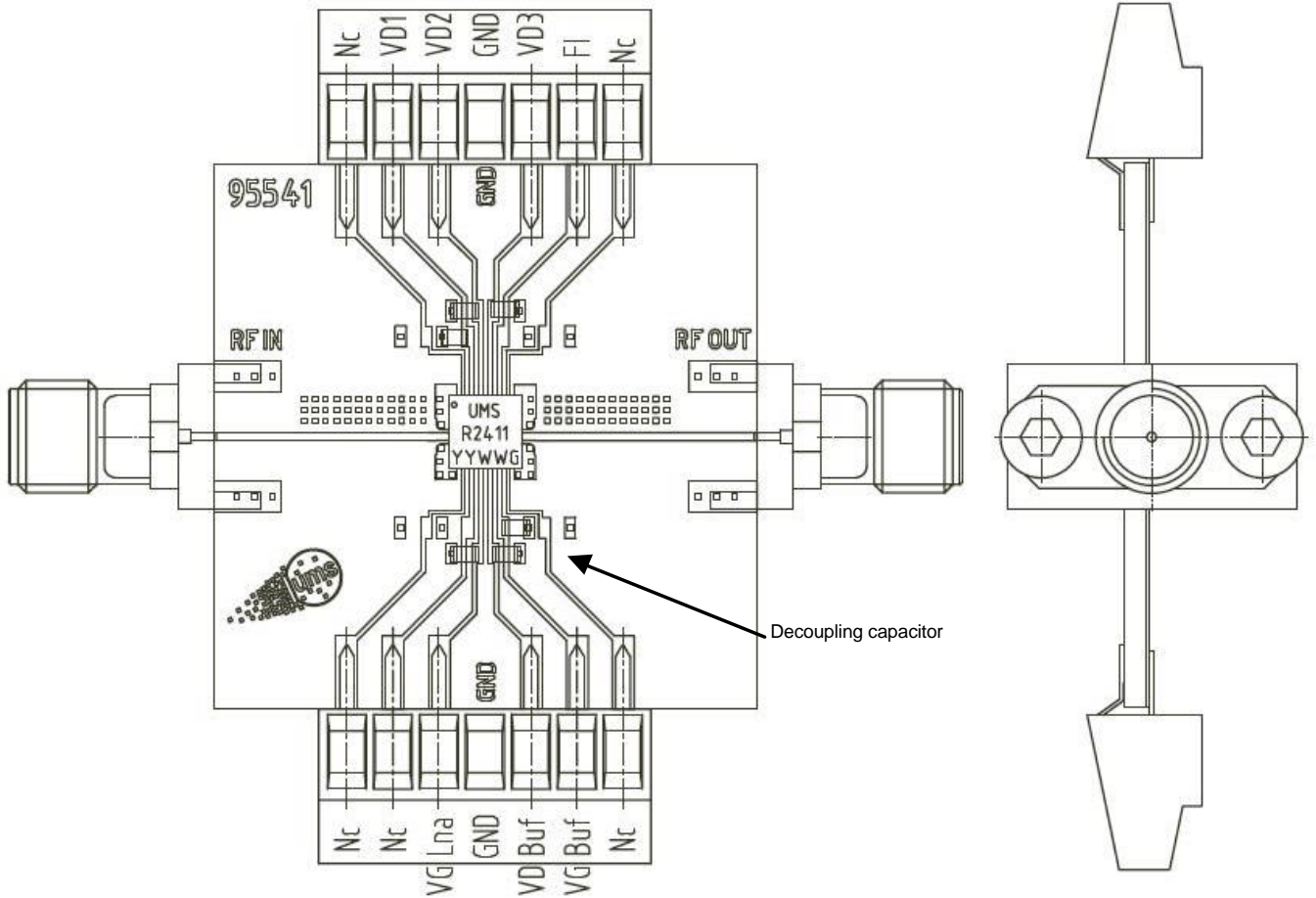

Remark :

- The label "RF OUT" printed out on this board corresponds to the LO Input Port.
- 10nF decoupling capacitors are used on DC biasing.

Preliminary

ESD sensitivity

Norm	Value
MIL-STD-1686C	HBM Class 1 (<1000V)
ESD STM5.1-1998	HBM Class 0 (<250V)

Package Information

Parameter	
Package body material	RoHS-compliant Low stress Injection Molded Plastic
Lead finish	100% matte Sn
MSL Rating	MSL1

**Recommended surface mount package assembly
(see UMS AN0017)**

For volume production the SMD type package can be treated as a standard surface mount component (please refer to the IPC/JEDEC JSTD-020C standard or equivalent). The assembly on the motherboard can be performed using a standard assembly process (e.g. stencil solder printing, standard pick-and-place machinery, and solder reflow oven). However, caution should be taken to perform a good and reliable contact over the whole pad area.

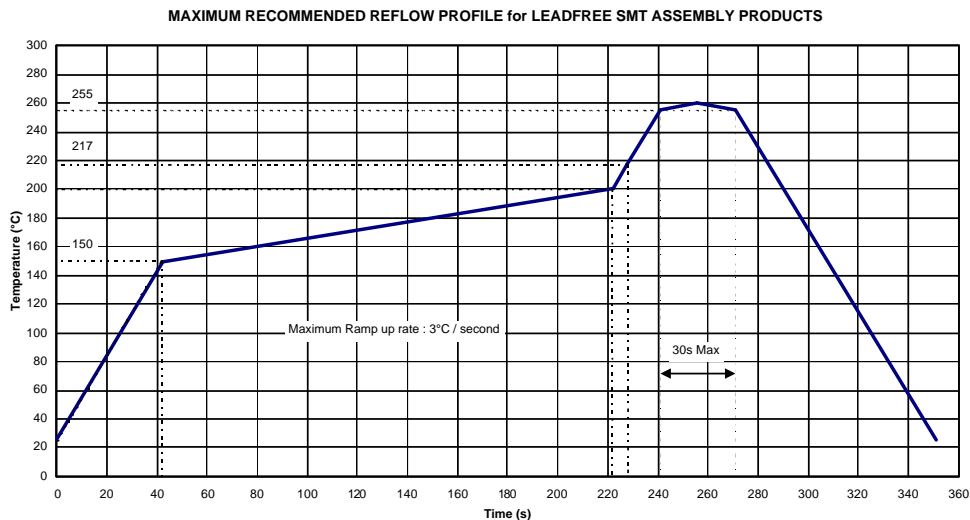

Attention:

The solder thickness after reflow should be typical 50µm [2 mils] and the lateral alignment between the package and the motherboard should be within 50µm [2 mils].

It is important for the performance of the product that the whole overlapping area between the motherboard and package pads is connected. Voids or other improper connections, in particular, between the ground pads on motherboard and package will lead to a deterioration of the RF performance and the heat dissipation. The latter effect can reduce drastically reliability and lifetime of the product.

Preliminary

Ordering Information

24L-QFN4x4 Lead Free Package : CHR2411-QDG/XY

Stick: XY=20 Tape and reel: XY=21

Information furnished is believed to be accurate and reliable. However **United Monolithic Semiconductors S.A.S.** assumes no responsibility for the consequences of use of such information nor for any infringement of patents or other rights of third parties which may result from its use. No license is granted by implication or otherwise under any patent or patent rights of **United Monolithic Semiconductors S.A.S.**. Specifications mentioned in this publication are subject to change without notice. This publication supersedes and replaces all information previously supplied. **United Monolithic Semiconductors S.A.S.** products are not authorised for use as critical components in life support devices or systems without express written approval from **United Monolithic Semiconductors S.A.S.**