



Continental Device India Limited

An ISO/TS 16949, ISO 9001 and ISO 14001 Certified Company



**SILICON PLANAR EPITAXIAL TRANSISTORS**

**CIL928A PNP**  
**CIL2328A NPN**

**TO-92**  
**Plastic Package**

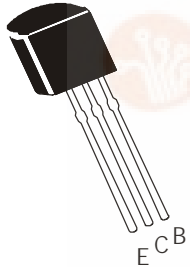

For use in Audio Power Amplifier

**ABSOLUTE MAXIMUM RATINGS**

DESCRIPTION	SYMBOL	VALUE	UNITS
Collector Base Voltage	$V_{CBO}$	30	V
Collector Emitter Voltage	$V_{CEO}$	30	V
Emitter Base Voltage	$V_{EBO}$	5.0	V
Collector Current Continuous	$I_C$	1.5	A
Collector Current Peak	$I_{CM}$	2.0	A
Power Dissipation @ $T_a=25^\circ\text{C}$	$P_D$	0.7	W
Operating and Storage Junction Temperature Range	$T_j, T_{stg}$	- 55 to +150	$^\circ\text{C}$

**ELECTRICAL CHARACTERISTICS ( $T_a=25^\circ\text{C}$  unless specified otherwise)**

DESCRIPTION	SYMBOL	TEST CONDITION	MIN	TYP	MAX	UNITS
Collector Base Voltage	$V_{CBO}$	$I_C=100\mu\text{A}, I_E=0$	30			V
Collector Emitter Voltage	$V_{CEO}$	$I_C=10\text{mA}, I_B=0$	30			V
Emitter Base Voltage	$V_{EBO}$	$I_E=1\text{mA}, I_C=0$	5			V
Collector Cut off Current	$I_{CBO}$	$V_{CB}=30\text{V}, I_E=0$			0.1	$\mu\text{A}$
Emitter Cut off Current	$I_{EBO}$	$V_{EB}=5\text{V}, I_C=0$			0.1	$\mu\text{A}$
DC Current Gain	$*h_{FE}$	$V_{CE}=2\text{V}, I_C=500\text{mA}$	100		320	
Collector Emitter Saturation Voltage	$*V_{CE(sat)}$	$I_C=1.5\text{A}, I_B=30\text{mA}$			2.0	V
Base Emitter On Voltage	$*V_{BE(on)}$	$V_{CE}=2\text{V}, I_C=500\text{mA}$			1.0	V
Transition Frequency	$f_T$	$I_C=500\text{mA}, V_{CE}=2\text{V}$		120		MHz
Output Capacitance	$C_{ob}$	$I_E=0, V_{CB}=10\text{V}, f=1\text{MHz}$				
		<b>NPN</b>		30		pF
		<b>PNP</b>		48		pF

**\* $h_{FE}$  Classification** **O : 100 - 200 ,** **Y : 160 - 320**

**\*Pulse Test: Pulse Width  $\leq 300\text{ms}$ , Duty Cycle  $\leq 2\%$**



CIL928A PNP  
 CIL2328A NPN

### TO-92 Plastic Package

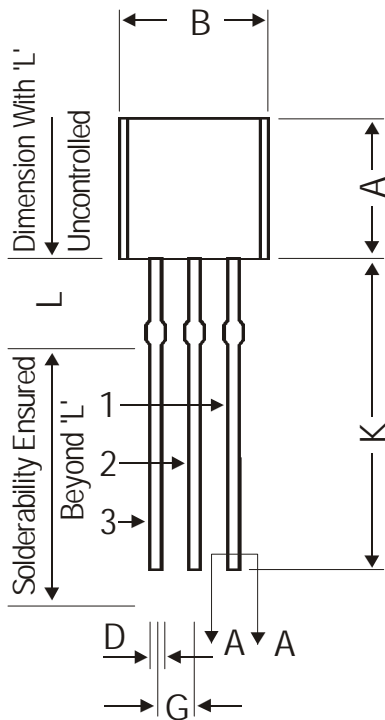

DIM	MIN.	MAX.
A	4.32	5.33
B	4.45	5.20
C	3.18	4.19
D	0.41	0.55
E	0.35	0.50
F	5 DEG	
G	1.14	1.40
H	1.20	1.40
K	12.70	—
L	1.982	2.082
M	1.03	1.20

All dimensions are in mm

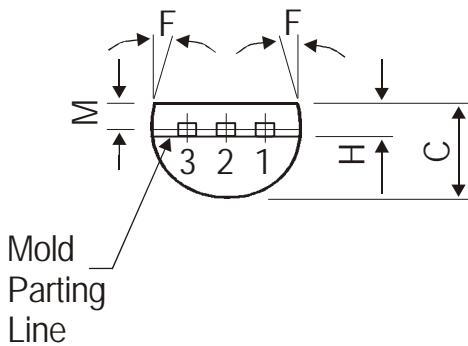

#### PIN CONFIGURATION

1. BASE
2. COLLECTOR
3. EMITTER

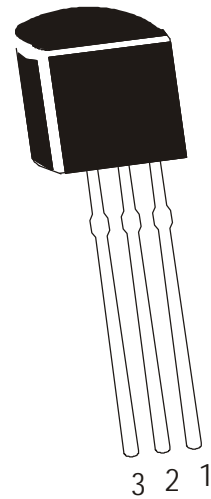

The TO-92 Package, Tape and Ammo Pack Drawings are correct as on the date of issue/revision of this Data Sheet.

The currently valid dimensions and information, may please be confirmed from the TO-92 Drawing in the Packages and Packing Section of the Product Catalogue.

#### Packing Details

PACKAGE	STANDARD PACK		INNER CARTON BOX		OUTER CARTON BOX		
	Details	Net Weight/Qty	Size	Qty	Size	Qty	Gr Wt
TO-92 Bulk	1K/polybag	200 gm/1K pcs	3" x 7.5" x 7.5"	5K	17" x 15" x 13.5"	80K	23 kgs
TO-92 T&A	2K/ammo box	645 gm/2K pcs	12.5" x 8" x 1.8"	2K	17" x 15" x 13.5"	32K	12.5 kgs

CIL928A PNP  
 CIL2328A NPN

TO-92  
 Plastic Package

TO-92 Tape and Ammo Pack

Tape Mechanical Data

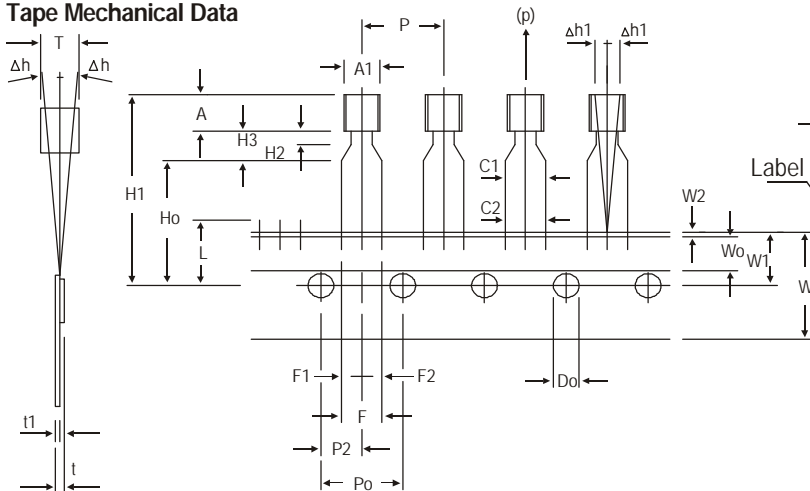

Ammo Pack Style

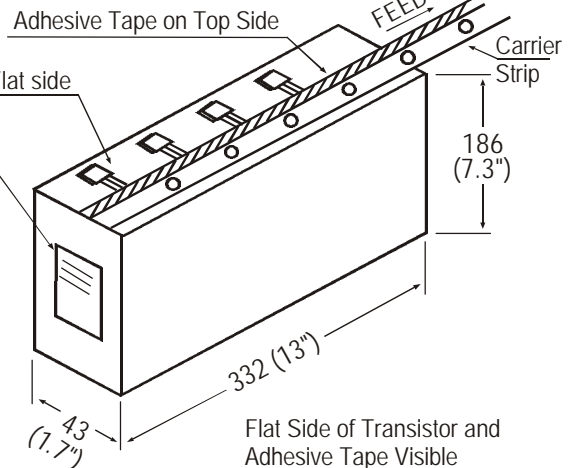

All dimensions are in mm

ITEM	SYMBOL	SPECIFICATION			
		MIN.	NOM.	MAX.	TOL .
BODY WIDTH	A1	4.0		4.8	
BODY HEIGHT	A	4.8		5.2	
BODY THICKNESS	T	3.9		4.2	
PITCH OF COMPONENT	P		12.7		± 1.0
*1 FEED HOLE PITCH	Po		12.7		± 0.3
*2 FEED HOLE CENTRE TO COMPONENT CENTRE	P2		6.35		± 0.4
DISTANCE BETWEEN OUTER LEADS	F		5.08		+ 0.6 - 0.2
*3 COMPONENT ALIGNMENT SIDE VIEW	Δh		0	1.0	
*4 COMPONENT ALIGNMENT FRONT VIEW	Δh1		0	1.3	
TAPE WIDTH	W		18		± 0.5
HOLD-DOWN TAPE WIDTH	W0		6		± 0.2
HOLE POSITION	W1		9		+ 0.7 - 0.5
HOLD-DOWN TAPE POSITION	W2		0.5		± 0.2
LEAD WIRE CLINCH HEIGHT	Ho		16		± 0.5
COMPONENT HEIGHT	H1			23.25	
LENGTH OF SNIPPED LEADS	L			11.0	
FEED HOLE DIAMETER	Do		4		± 0.2
*5 TOTAL TAPE THICKNESS	t			1.2	
LEAD - TO - LEAD DISTANCE	F1, F2		2.54		+ 0.4 - 0.1
STAND OFF	H2	0.45		1.45	
CLINCH HEIGHT	H3			3.0	
LEAD PARALLELISM	C1 - C2			0.22	
PULL - OUT FORCE	(p)	6N			

NOTES

- Maximum alignment deviation between leads will not to be greater than 0.2mm.
- Maximum non-cumulative variation between tape feed holes shall not exceed 1 mm in 20 pitches.
- Holddown tape will not exceed beyond the edge(s) of carrier tape and there shall be no exposure of adhesive.
- There will be no more than three (3) consecutive missing components in a tape.
- A tape trailer, having at least three feed holes are provided after the last component in a tape.
- Splices should not interfere with the sprocket feed holes.

REMARKS

- \*1 Cumulative pitch error 1.0 mm/20 pitch
- \*2 To be measured at bottom of clinch
- \*3 At top of body
- \*4 At top of body
- \*5 t1 0.3 – 0.6 mm

## Notes

**CIL928A PNP**  
**CIL2328A NPN**

**TO-92**  
**Plastic Package**

### Disclaimer

The product information and the selection guides facilitate selection of the CDIL's Discrete Semiconductor Device(s) best suited for application in your product(s) as per your requirement. It is recommended that you completely review our Data Sheet(s) so as to confirm that the Device(s) meet functionality parameters for your application. The information furnished in the Data Sheet and on the CDIL Web Site/CD are believed to be accurate and reliable. CDIL however, does not assume responsibility for inaccuracies or incomplete information. Furthermore, CDIL does not assume liability whatsoever, arising out of the application or use of any CDIL product; neither does it convey any license under its patent rights nor rights of others. These products are not designed for use in life saving/support appliances or systems. CDIL customers selling these products (either as individual Discrete Semiconductor Devices or incorporated in their end products), in any life saving/support appliances or systems or applications do so at their own risk and CDIL will not be responsible for any damages resulting from such sale(s).

CDIL strives for continuous improvement and reserves the right to change the specifications of its products without prior notice.



CDIL is a registered Trademark of  
Continental Device India Limited

C-120 Naraina Industrial Area, New Delhi 110 028, India.  
Telephone + 91-11-579 6150 Fax + 91-11-579 9569, 579 5290  
e-mail sales@cdil.com www.cdil.com, www.cdilsemi.com