

60 MHz - 3.0 GHz High Dynamic Range Amplifier



August 2006 - Rev 26-Aug-06

CMM6001-SC
RoHS

Features

- ✕ 60 MHz to 3.0 GHz Frequency Range
- ✕ 37 dBm Output IP3
- ✕ 2.5 dB Noise Figure
- ✕ 12.3 dB Gain
- ✕ 20.5 dBm P1dB
- ✕ SOT-89 SMT Package, RoHS Compliant
- ✕ Single Power Supply
- ✕ +3V to +5V Voltage Rail

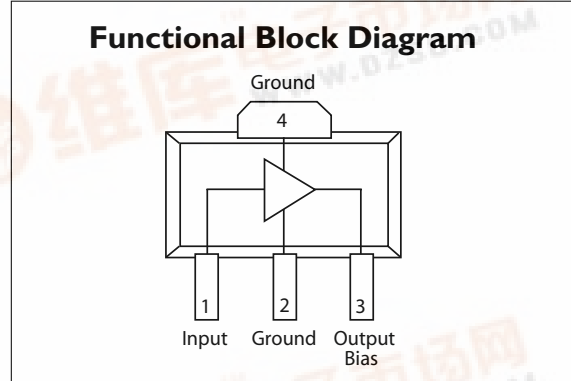

Description

The CMM6001-SC is a high dynamic range amplifier designed for applications operating within the 60 MHz to 3.0 GHz frequency range. It is an ideal solution for transmit and receive functions where high linearity is required. The amplifier has the flexibility of being optimized for a number of wireless applications. The combination of low NF and high IP3 at the same bias point make it an ideal transmit or receive solution when used in applications including cellular and PCS (personal communications service) operating from 0.8 to 2.2 GHz; MMDS (multichannel multipoint distribution systems) operating from 2.2 to 2.7 GHz; and WLAN (wireless LAN) operating at 2.4 GHz.

The CMM6001-SC is packaged in a low-cost space efficient, surface mount SOT-89 package which provides excellent electrical stability and low thermal resistance. All devices are 100% RF and DC tested.

Applications

- ✕ Wireless Local Loop Transmit and Receive
- ✕ UNH Transmit and Receive
- ✕ Dual Band 802.11 WLAN
- ✕ WiMAX

Absolute Maximum Ratings

Supply Voltage	+6.0 V
RF Input Power	+10 dBm
Storage Temperature	-55°C to 150°C
Junction Temperature	150°C
Operating Temperature	-40°C to +85°C
Thermal Resistance	65° C/W

Operation of this device above any of these parameters may cause damage.

Electrical Characteristics

Unless otherwise specified, the following specifications are guaranteed at room temperature in a Mimix test fixture.

Parameter	Condition	Min	Typ	Max	Units
Frequency Range		0.06		3.0	GHz
Gain	Externally matched	10.5	12.5		dB
Input Return Loss	Externally matched		-10		dB
Output IP3		+33	+37		dBm
Noise Figure			2.8		dB
Output P1dB			20.5		dBm
Operating Current Range		55	75	100	mA
Supply Voltage			5.0		V

Notes:

1. T = 25°C, Vdd = 5.0, Frequency = 800 MHz, 50 Ohm system

2. OIP3 measured with two tones at output power of 5 dBm/tone separated by 10 MHz.



60 MHz - 3.0 GHz High Dynamic Range Amplifier



August 2006 - Rev 26-Aug-06

CMM6001-SC
RoHS

Application Circuit

Parameter	Typical			Units
	900	1900	2400	
Frequency Range	900	1900	2400	MHz
Gain	12.5	11.5	10.8	dB
Input Return Loss	-18.0	-11.5	-10.0	dB
Output Return Loss	-17	-16	-15	dB
Output IP3	+37	+37	+37	dBm
Output P1dB	20.5	19.5	19.5	dBm
Noise Figure	2.7	2.8	2.9	dB

Notes:
1. Typical values reflect performance in recommended application circuit.

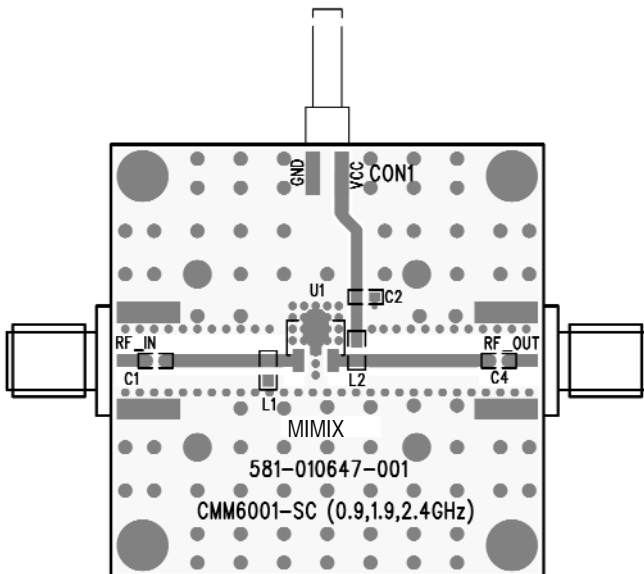
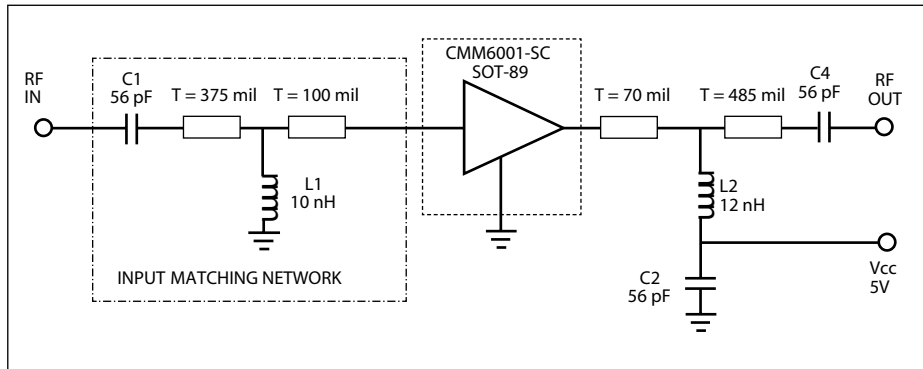
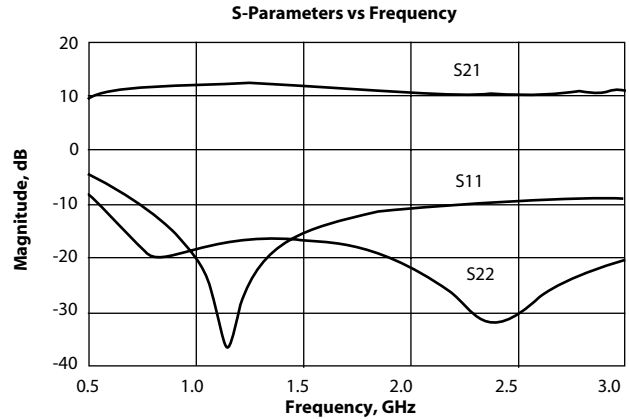

Ref Designator	Value	Description	Size
C1, C4	56 pF	MCH185A560JK	0603
C2	0.1 μF	VITR 0.1 μF 25V CER CAP 0603 X7R 10%	0603
L1	10 nH	TOKO LL 1608-F10NJ	0603
L2	12 nH	TOKO LL 1608-F12NK	0603

60 MHz - 3.0 GHz High Dynamic Range Amplifier



August 2006 - Rev 26-Aug-06

CMM600I-SC
XRoHS

Typical Scattering Parameters (Vd = +5V, Ids = 75 mA, T = 22°C, unmatched device in a 50 ohm system)

Frequency (MHz)	S ₁₁		S ₂₁		S ₁₂		S ₂₂	
	(Mag)	(Ang)	(Mag)	(Ang)	(Mag)	(Ang)	(Mag)	(Ang)
300	0.313	-38.56	4.435	159.70	0.118	-2.96	0.090	-50.49
400	0.307	-43.12	4.382	155.90	0.118	-7.56	0.078	-44.05
500	0.305	-48.70	4.344	151.60	0.118	-11.62	0.072	-38.92
600	0.304	-54.84	4.309	147.20	0.117	-15.23	0.070	-35.16
700	0.305	-61.22	4.270	142.70	0.117	-18.70	0.070	-32.63
800	0.307	-67.68	4.234	138.20	0.117	-22.02	0.071	-31.18
900	0.310	-74.20	4.197	133.60	0.116	-25.29	0.073	-30.88
1000	0.313	-80.57	4.158	129.00	0.116	-28.50	0.076	-31.21
1100	0.316	-86.85	4.122	124.40	0.115	-31.71	0.078	-31.76
1200	0.318	-93.11	4.085	119.90	0.115	-34.88	0.082	-32.50
1300	0.322	-99.29	4.043	115.30	0.114	-37.94	0.086	-33.84
1400	0.324	-105.40	4.004	110.70	0.114	-40.98	0.090	-35.26
1500	0.327	-111.40	3.960	106.20	0.113	-44.08	0.094	-36.85
1600	0.329	-117.40	3.919	101.70	0.112	-47.07	0.097	-38.64
1700	0.332	-123.40	3.879	97.22	0.112	-50.08	0.101	-40.76
1800	0.335	-129.20	3.838	92.77	0.111	-53.15	0.104	-42.85
1900	0.337	-135.00	3.799	88.32	0.110	-56.07	0.108	-45.06
2000	0.339	-140.80	3.760	83.87	0.109	-59.11	0.111	-47.37
2100	0.340	-146.50	3.720	79.47	0.109	-62.08	0.114	-49.53
2200	0.341	-152.30	3.679	75.03	0.108	-65.06	0.118	-51.72
2300	0.342	-158.20	3.639	70.64	0.107	-67.98	0.121	-53.76
2400	0.343	-164.10	3.600	66.25	0.106	-71.02	0.124	-55.82
2500	0.343	-169.80	3.561	61.89	0.105	-73.95	0.127	-57.84
2600	0.344	-175.80	3.524	57.51	0.105	-76.90	0.130	-59.75
2700	0.344	178.20	3.486	53.16	0.104	-79.96	0.133	-61.67
2800	0.344	172.20	3.448	48.81	0.103	-82.91	0.135	-63.35
2900	0.344	166.10	3.410	44.46	0.102	-85.93	0.137	-65.11
3000	0.344	160.00	3.373	40.13	0.101	-88.99	0.139	-66.85

S-Parameter Data Files are available online at www.mimixbroadband.com.

60 MHz - 3.0 GHz High Dynamic Range Amplifier



August 2006 - Rev 26-Aug-06

CMM600I-SC
RoHS

Physical Dimensions

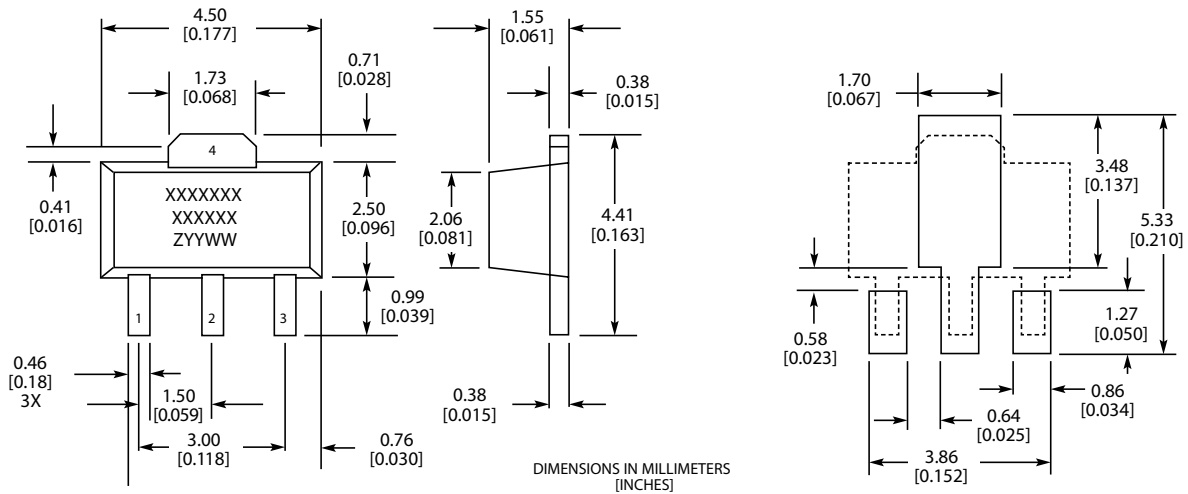

MARKINGS:
 XXXXXXX = MIMIX MODEL NO.
 XXXXXX = WAFER LOT NO.
 ZYYWW = DATE CODE (YR/WEEK)
 FIRST LETTER COUNTRY OF ORIGIN IF OTHER THAN USA

60 MHz - 3.0 GHz High Dynamic Range Amplifier



August 2006 - Rev 26-Aug-06

CMM6001-SC
XRoHS

Handling and Assembly Information

CAUTION! - Mimix Broadband MMIC Products contain gallium arsenide (GaAs) which can be hazardous to the human body and the environment. For safety, observe the following procedures:

- Do not ingest.
- Do not alter the form of this product into a gas, powder, or liquid through burning, crushing, or chemical processing as these by-products are dangerous to the human body if inhaled, ingested, or swallowed.
- Observe government laws and company regulations when discarding this product. This product must be discarded in accordance with methods specified by applicable hazardous waste procedures.

Life Support Policy - Mimix Broadband's products are not authorized for use as critical components in life support devices or systems without the express written approval of the President and General Counsel of Mimix Broadband. As used herein: (1) Life support devices or systems are devices or systems which, (a) are intended for surgical implant into the body, or (b) support or sustain life, and whose failure to perform when properly used in accordance with instructions for use provided in the labeling, can be reasonably expected to result in a significant injury to the user. (2) A critical component is any component of a life support device or system whose failure to perform can be reasonably expected to cause the failure of the life support device or system, or to affect its safety or effectiveness.

Package Attachment - This packaged product from Mimix Broadband is provided as a rugged surface mount package compatible with high volume solder installation. Care should be taken not to apply heavy pressure to the top or base material to avoid package damage. Vacuum tools or other suitable pick and place equipment may be used to pick and place this part. Care should be taken to ensure that there are no voids or gaps in the solder connection so that good RF, DC and ground connections are maintained. Voids or gaps can eventually lead not only to RF performance degradation, but reduced reliability and life of the product due to thermal stress.

Mimix Lead-Free RoHS Compliant Program - Mimix has an active program in place to meet customer and governmental requirements for eliminating lead (Pb) and other environmentally hazardous materials from our products. All Mimix RoHS compliant components are form, fit and functional replacements for their non-RoHS equivalents. Lead plating of our RoHS compliant parts is 100% matt tin (Sn) over copper alloy and is backwards compatible with current standard SnPb low-temperature reflow processes as well as higher temperature (260°C reflow) "Pb Free" processes.

Ordering Information

Part Number for Ordering

CMM6001-SC-0G00

CMM6001-SC-0G0T

PB-CMM6001-SC-0000

Package

Matte Tin plated RoHS compliant SOT-89 surface-mount power package in bulk quantity

Matte Tin plated RoHS compliant SOT-89 surface-mount power package in tape and reel

Evaluation Board with SMA connectors for CMM6001-SC

We also offer the plastic package with SnPb (Tin-Lead) or NiPdAu plating. Please contact your regional sales manager for more information regarding different plating types.