

**CMXSH2-4LS**  
**SUPERmini™**  
**DUAL PAIR, IN-SERIES**  
**SURFACE MOUNT**  
**LOW V<sub>F</sub> SCHOTTKY DIODES**

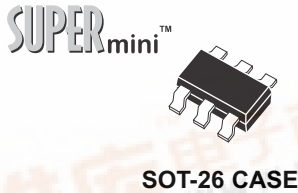

**Central™**  
**Semiconductor Corp.**

**DESCRIPTION:**

The CENTRAL SEMICONDUCTOR CMXSH2-4LS consists of Dual, In-Series pairs of Low V<sub>F</sub> Schottky Diodes, manufactured in a SUPERmini™ SOT-26 surface mount package. This device can be configured as a bridge rectifier using the optional mounting pad configuration on the following page.

**MARKING CODE: CXS4L**

**MAXIMUM RATINGS** (T<sub>A</sub>=25°C unless otherwise noted)

	SYMBOL		UNITS
Peak Repetitive Reverse Voltage	V <sub>RRM</sub>	40	V
Continuous Forward Current	I <sub>F</sub>	200	mA
Peak Repetitive Forward Current	I <sub>FRM</sub>	350	mA
Forward Surge Current, tp=10ms	I <sub>FSM</sub>	1.0	A
Power Dissipation	P <sub>D</sub>	350	mW
Operating and Storage Junction Temperature	T <sub>J</sub> , T <sub>stg</sub>	-65 to +150	°C
Thermal Resistance	θ <sub>JA</sub>	357	°C/W

**ELECTRICAL CHARACTERISTICS PER DIODE** (T<sub>A</sub>=25°C unless otherwise noted)

SYMBOL	TEST CONDITIONS	MIN	TYP	MAX	UNIT
I <sub>R</sub>	V <sub>R</sub> =20V		11	50	μA
BV <sub>R</sub>	I <sub>R</sub> =100μA	40	53		V
V <sub>F</sub>	I <sub>F</sub> =10mA		0.24	0.325	V
V <sub>F</sub>	I <sub>F</sub> =100mA		0.35	0.4	V
V <sub>F</sub>	I <sub>F</sub> =200mA		0.42	0.5	V
C <sub>T</sub>	V <sub>R</sub> =4.0V, f=1 MHz		8.5	10	pF
t <sub>rr</sub>	I <sub>F</sub> =I <sub>R</sub> =30mA, Rec. To 3.0mA, R <sub>L</sub> =100Ω		4.0	5.0	ns

R1 (17-June 2005)

**SOT-26 CASE - MECHANICAL OUTLINE**

SYMBOL	DIMENSIONS			
	INCHES		MILLIMETERS	
	MIN	MAX	MIN	MAX
A	0.004	0.007	0.11	0.19
B	0.016	-	0.40	-
C	-	0.004	-	0.10
D	0.039	0.047	1.00	1.20
E	0.074	0.075	1.88	1.92
F	0.037	0.038	0.93	0.97
G	0.102	0.118	2.60	3.00
H	0.059	0.067	1.50	1.70
I	0.016		0.41	
J	0.110	0.118	2.80	3.00

SOT-26 (REV: R2)

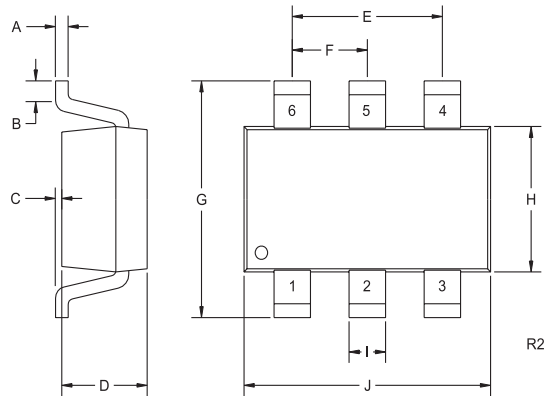

**OPTIONAL MOUNTING PAD LAYOUT**

(Dimensions in mm)

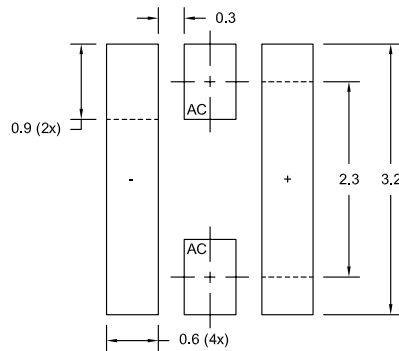

**For Bridge Rectifier Application**

**MARKING CODE: CXS4L**

**PIN CONFIGURATION**

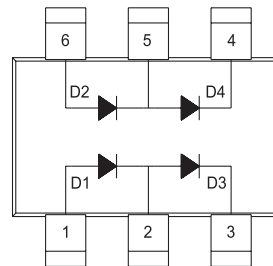

**LEAD CODE**

- 1) ANODE D1
- 2) CATHODE D1, ANODE D3
- 3) CATHODE D3
- 4) CATHODE D4
- 5) ANODE D4, CATHODE D2
- 6) ANODE D2