

Ultra-linear Mixer with Integrated IF Amp and LO Buffer

Description

CMY212 is a general purpose down-converter device designed for multiple applications such as cellular and PCS mobile phones, ISM bands, GPS receivers, L-band satellite terminals, WLAN and pagers. Due to its excellent intermodulation characteristics and its high conversion gain, CMY212 is particularly suited for CDMA receiver applications.

The device combines an ultra-linear mixer with LO - driver and a single stage IF-amplifier in a very small SCT598 package. The mixer section of CMY212 combines low conversion losses and excellent intermodulation characteristics with low requirements of LO - and DC-power. The internal level controlled LO-Buffer enables a good performance over a wide LO level range. The input and output matching of the IF amplifier can be adapted externally within a frequency range from 45 to 250 MHz.

Features

- Typical overall performance at cellular frequencies (for $P_{LO} = -4\text{dBm}$ operation conditions: 3V, 11 mA; $f_{RF} = 881\text{ MHz}$; $f_{LO} = 966\text{ MHz}$):
 - Gain 10 dB
 - Input IP3 9 dBm
 - Noise figure 8 dB
- RF-frequency range 0.5 - 2.5 GHz
- Operating voltage range: 2.6 to 5V
- Small SCT598 plastic package

Applications

- Down Converter for Multiple Wireless Applications
- Cellular and PCS Mobile Phones
- Particularly Suited for CDMA Receivers
- ISM and WLAN Receivers
- GPS Receivers

Package Outline and Pin Configuration, SCT598

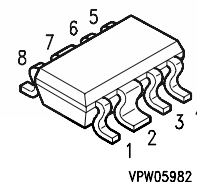
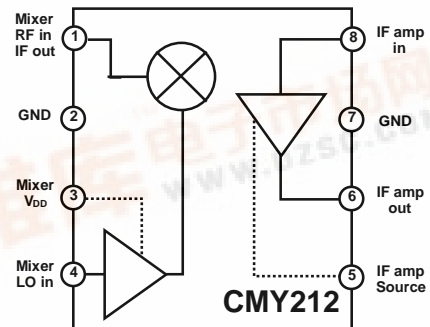

CMY212 Datasheet

Maximum Ratings

Parameter	Port	Symbol	Value		Unit
			min	max	
Supply Voltage	3,6	V_{DD}	0	5	V
DC-Voltage at LO Input	4	V_6	-3	0,5	V
DC-Voltage at Mixer RF-IF Port	1	V_8	- 0,5	+ 0,5	V
Power into Mixer RF Port	1	P_{RF}		10	dBm
Power into LO Input	4	$P_{in,LO}$	-10	10	dBm
Channel Temperature		T_{Ch}		150	°C
Operating Temperature		T_{op}	-30	85	°C
Storage Temperature		T_{stg}	-55	150	°C
Thermal Resistance*					
Channel to Soldering Point (GND)		R_{thChS}		260	K/W

CMY212 Datasheet

Electrical Characteristics

Parameter,	Comment	min	typ	max	Unit
RF - frequency range	external match	0.5	-	2.5	GHz
LO - Frequency range	external match	0.5	-	2.5	GHz
IF Frequency range	external match	45		250	MHz

Typical performance at cellular frequencies*:

$T_a = 25^\circ\text{C}$; $V_{DD} = 3\text{V}$, $f_{RF} = 881\text{MHz}$; $f_{LO} = 966\text{MHz}$; $P_{LO} = -4\text{dBm}$; $f_{IF} = 85\text{MHz}$,
 $Z_S = Z_L = 50\ \Omega$; unless otherwise specified

Parameter, Test Conditions	Symbol	Min	typ	max	Unit
Total operating Current (Mixer + IF amplifier)	I_{op}	-	11	-	mA
Conversion Gain	G_c	-	10	-	dB
SSB Noise Figure	F_{ssb}	-	8	-	dB
RF Input -/ IF Output return loss (external matching required)	RFIrl / IFOrl	-	10	-	dB
3rd Order Input Intercept Point	IIP3	-	10	-	dBm

Test conditions at PCS frequencies:

$T_a = 25^\circ\text{C}$; $V_{DD} = 3\text{V}$, $f_{RF} = 1960\text{MHz}$; $f_{LO} = 1750\text{MHz}$; $P_{LO} = -4\text{dBm}$; $f_{IF} = 210\text{MHz}$,
 $Z_S = Z_L = 50\ \Omega$; unless otherwise specified

Parameter, Test Conditions	Symbol	Min	Typ	max	Unit
Total operating Current (Mixer + IF amplifier)	I_{op}	-	12	14	mA
Conversion Gain	G_c	8.5	9.5	-	dB
SSB Noise Figure	F_{ssb}	-	8.5	-	dB
RF Input -/ IF output return loss (external matching required)	RFIrl / IFOrl	-	10	-	dB
3rd Order Input Intercept Point	IIP3	10	11.5	-	dBm

* IMPORTANT NOTE:

During production, the RF performance at PCS frequencies is screened. The passed devices also achieve the specified RF performance at cellular frequencies.

CMY212 Datasheet

Electrical Characteristics (cont)

Typical device behavior at cellular frequencies:

$T_a = 25^\circ\text{C}$; $V_{DD} = 3\text{V}$; $f_{RF} = 881\text{MHz}$; $f_{LO} = 966\text{MHz}$; $f_F = 85\text{MHz}$;
 $Z_S = Z_L = 50\ \Omega$; unless otherwise specified

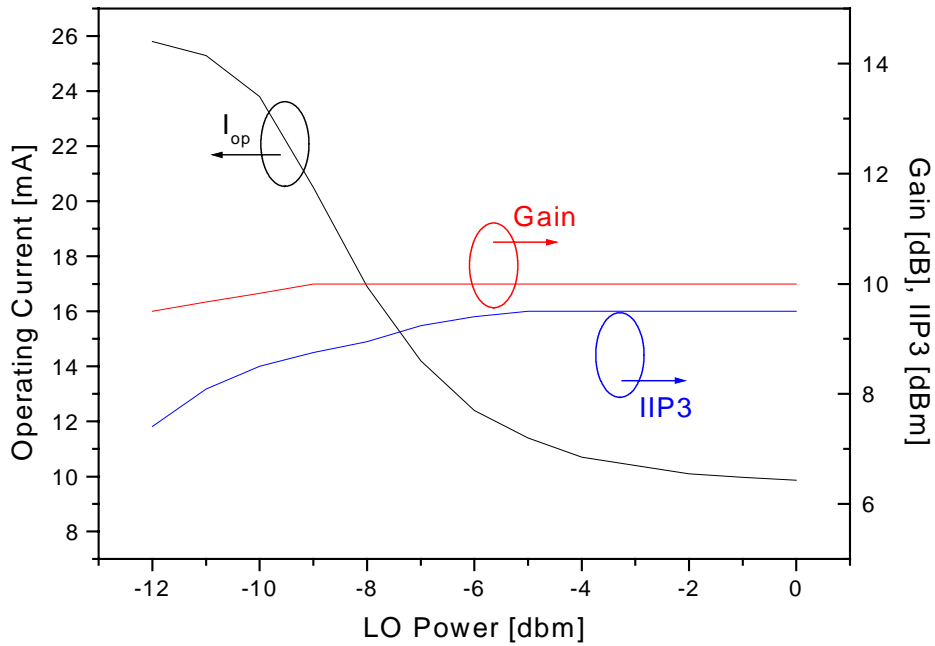

Typical device behavior at PCS frequencies:

$T_a = 25^\circ\text{C}$; $V_{DD} = 3\text{V}$; $f_{RF} = 1960\text{MHz}$; $f_{LO} = 1750\text{MHz}$; $f_F = 210\text{MHz}$;
 $Z_S = Z_L = 50\ \Omega$; unless otherwise specified

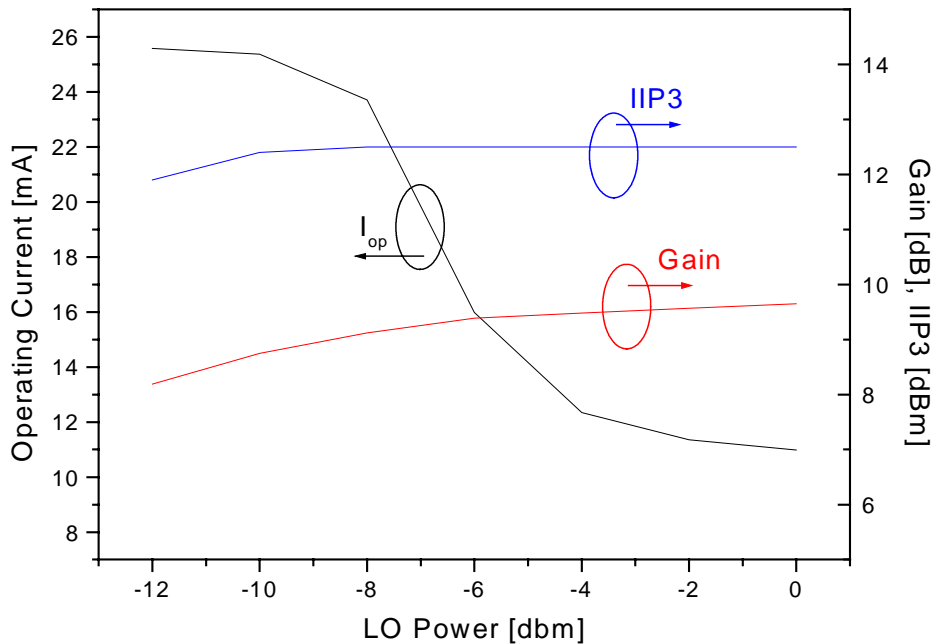

CMY212 Datasheet

Applications Information

Test Circuit:

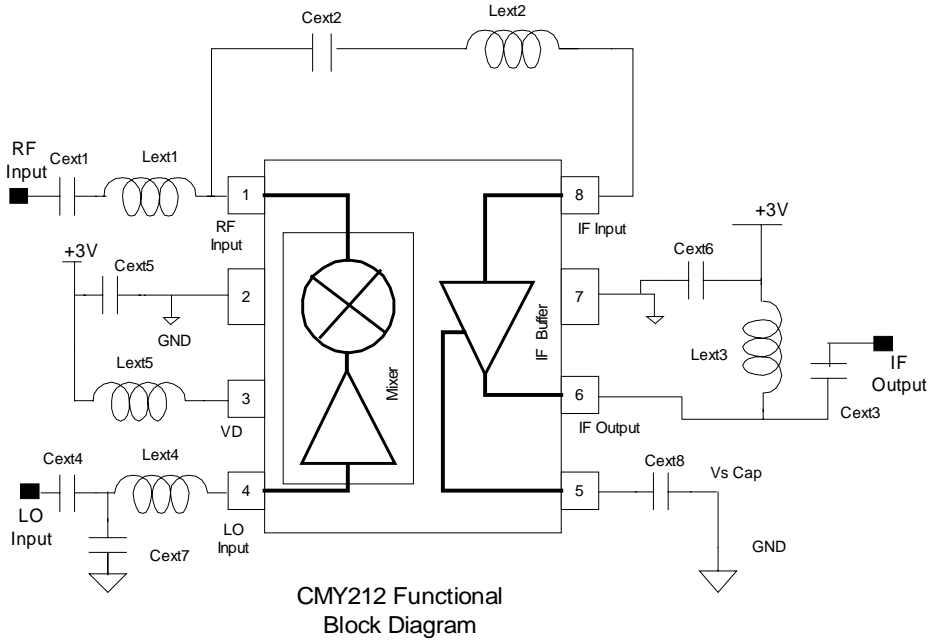

External components for cellular frequencies

$$f_{RF} = 875\text{MHz}; f_{LO} = 960\text{MHz}; f_{IF} = 85\text{MHz}$$

Capacitors	(Murata 0402)	Inductors	(Toko)
Cext1	2 pF	Lext1	18 nH LL1005
Cext2	1 nF	Lext2	270 nH LL1608
Cext3	20 pF	Lext3	220 nH LL1608
Cext4	100 pF	Lext4	12 nH LL1005
Cext5	1 nF	Lext5	15 nH LL1005
Cext6	1 nF		
Cext7	3.3 pF		
Cext8	100 nF	Lext8	22 nH LL1005

External components for PCS frequencies

$$f_{RF} = 1960\text{MHz}; f_{LO} = 1750\text{MHz}; f_{IF} = 210\text{MHz}$$

Capacitors	(Murata 0402)	Inductors	(Toko)
Cext1	1 pF	Lext1	5.6 nH LL1005
Cext2	1 nF	Lext2	68 nH LL1608
Cext3	8 pF	Lext3	68 nH LL1608
Cext4	22 pF	Lext4	4.7 nH LL1005
Cext5	1 nF	Lext5	4.7 nH LL1005
Cext6	1 nF		
Cext7	3 pF		
Cext8	100 nF		

CMY212 Datasheet

Applications Information (cont)

PCB Layout:

Size: 35 x 35 mm²

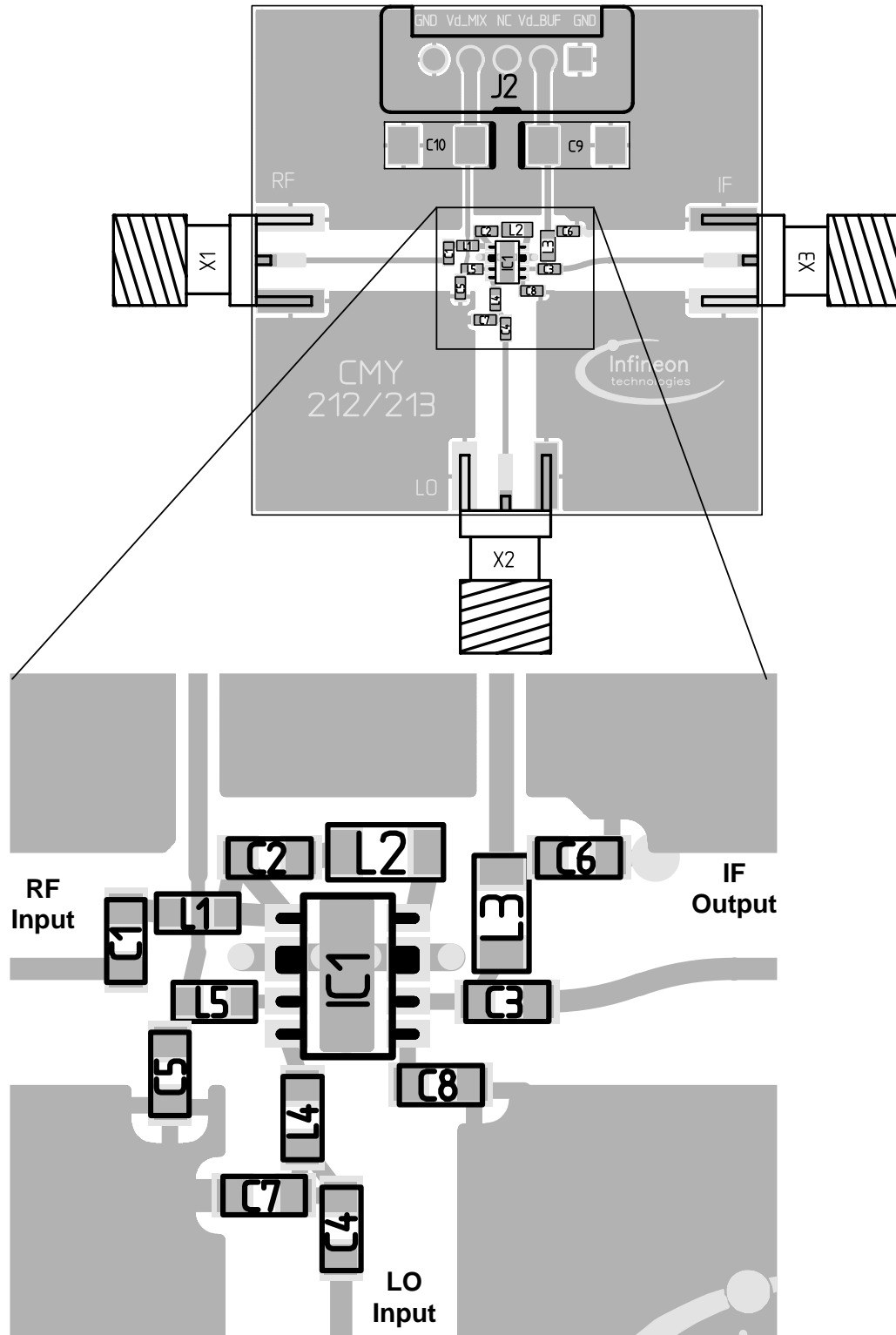

CMY212 Datasheet

General description and notes

CMY212 is a general purpose down-converter device designed for multiple applications such as cellular and PCS mobile phones, ISM bands, GPS receivers, L-band satellite terminals, WLAN and pagers. Due to its excellent intermodulation characteristics and its high conversion gain, CMY212 is particularly suited for CDMA receiver applications.

The device combines an ultra-linear mixer with LO - driver and a single stage IF-amplifier in a very small SCT598 package. The mixer section of CMY212 combines low conversion losses and excellent intermodulation characteristics with low requirements of LO - and DC-power. The internal level controlled LO-Buffer enables a good performance over a wide LO level range. The input and output matching of the IF amplifier can be adapted externally within a frequency range from 45 to 250 MHz.

Semiconductor Device Outline SCT598-8-1

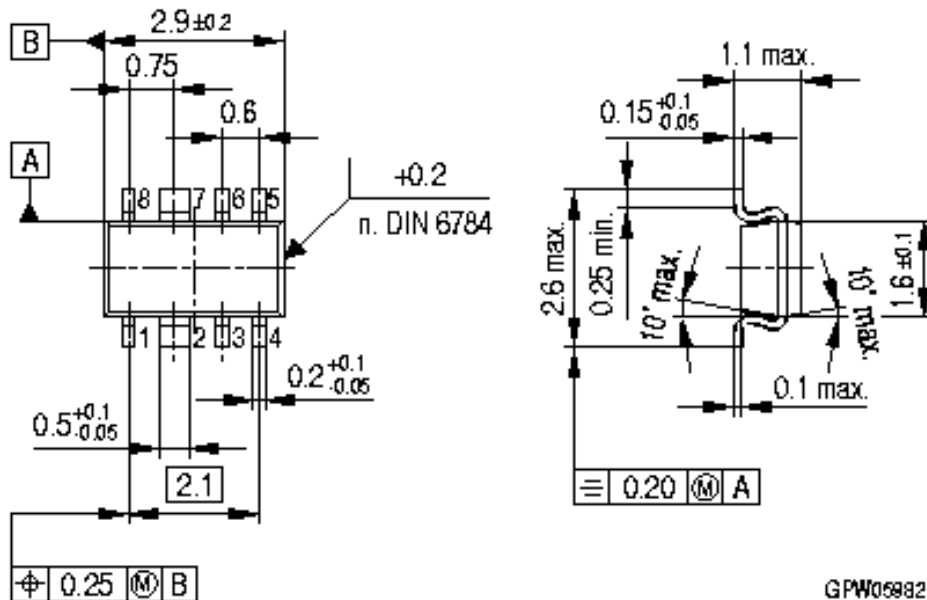

CMY212 Datasheet

Ordering Information

Type	Marking	Ordering code (tape and reel)	Package ¹⁾
CMY212	M5s	Q62702-M0026	SCT598-8-1

Additional Information

This part is compliant with RoHS directive (Restrictions on the Use of Certain Hazardous Substances in Electrical and Electronic Equipment).

The part is rated Moisture Sensitivity Level 1 at 260°C per JEDEC standard IPC/JEDEC J-STD-020.

ESD: **E**lectro**s**tatic **d**ischarge sensitive device. Observe handling Precautions.

For latest specifications, additional product information, worldwide sales and distribution locations, and information about TriQuint:

Web: www.triquint.com Tel: (503) 615-9000

Email: info_wireless@tqs.com Fax: (503) 615-8902

For technical questions and additional information on specific applications:

Email: info_wireless@tqs.com

The information provided herein is believed to be reliable; TriQuint assumes no liability for inaccuracies or omissions. TriQuint assumes no responsibility for the use of this information, and all such information shall be entirely at the user's own risk. Prices and specifications are subject to change without notice. No patent rights or licenses to any of the circuits described herein are implied or granted to any third party.

TriQuint does not authorize or warrant any TriQuint product for use in life-support devices and/or systems. Copyright © 2005 TriQuint Semiconductor, Inc. All rights reserved.