



CM2836/B/C

300mA Low ESR CMOS LDO WITH ENABLE

GENERAL DESCRIPTION

The CM2836/B/C family is a positive voltage linear regulator developed utilizing CMOS technology featured low quiescent current (30µA typ.), low dropout voltage, and high output voltage accuracy, making them ideal for battery applications. EN input connected to CMOS has low bias current. The space-saving SC70 package is attractive for "Pocket" and "Hand Held" applications.

These rugged devices have both Thermal Shutdown, and Current limit to prevent device failure under the "Worst" of operating conditions.

In application requiring a low noise, regulated supply, place a 1000pF capacitor between Bypass and Ground.

The CM2836/B/C is stable with a Low ESR output capacitance of 1.0µF or greater.

APPLICATIONS

- ◆ Battery-powered devices
- ◆ Personal communication devices
- ◆ Home electric/electronic appliances
- ◆ PC peripherals

TYPICAL APPLICATIONS

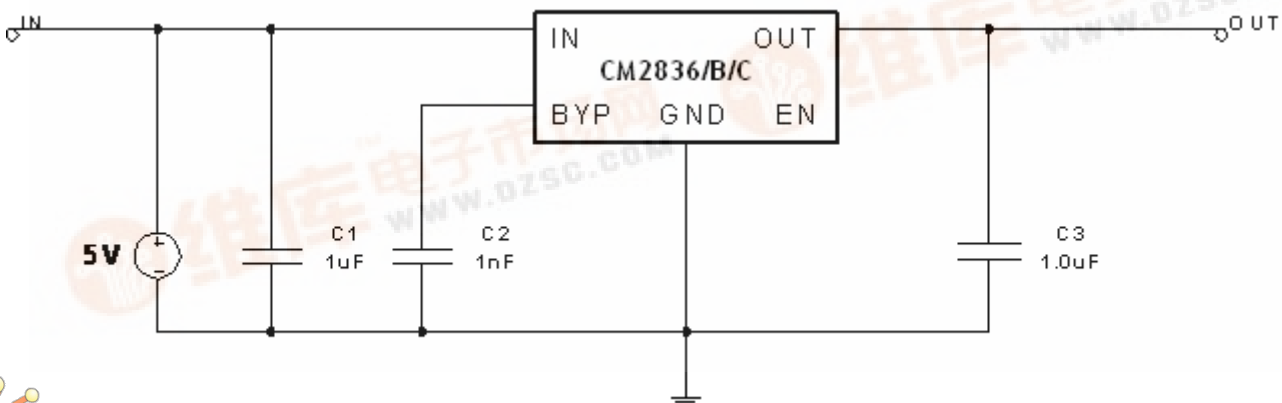

FEATURES

- ◆ Very Low Dropout Voltage
- ◆ Low Current Consumption: Typ. 30µA, Max. 35µA
- ◆ More Options Output Voltage
- ◆ High Accuracy Output Voltage: +/- 2%
- ◆ Guaranteed 300mA Output
- ◆ Input Range up to 7.0V
- ◆ Thermal Shutdown
- ◆ Current Limiting
- ◆ Stability with Low ESR Capacitors
- ◆ Compact Package: SOT-23 / SOT-89 / SC70
- ◆ Factory Pre-set Output Voltages
- ◆ Low Temperature Coefficient



PIN CONFIGURATION

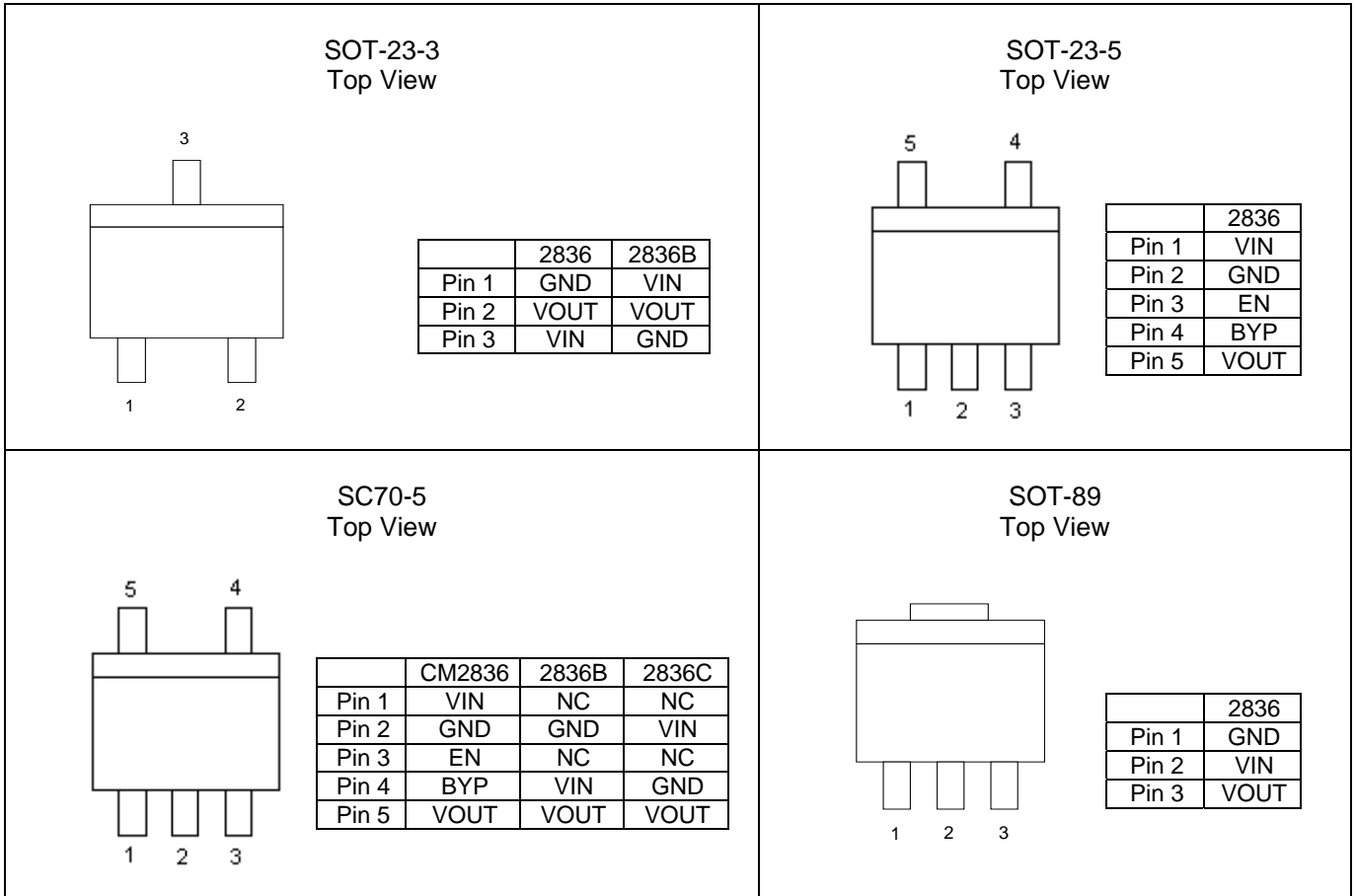

BLOCK DIAGRAM

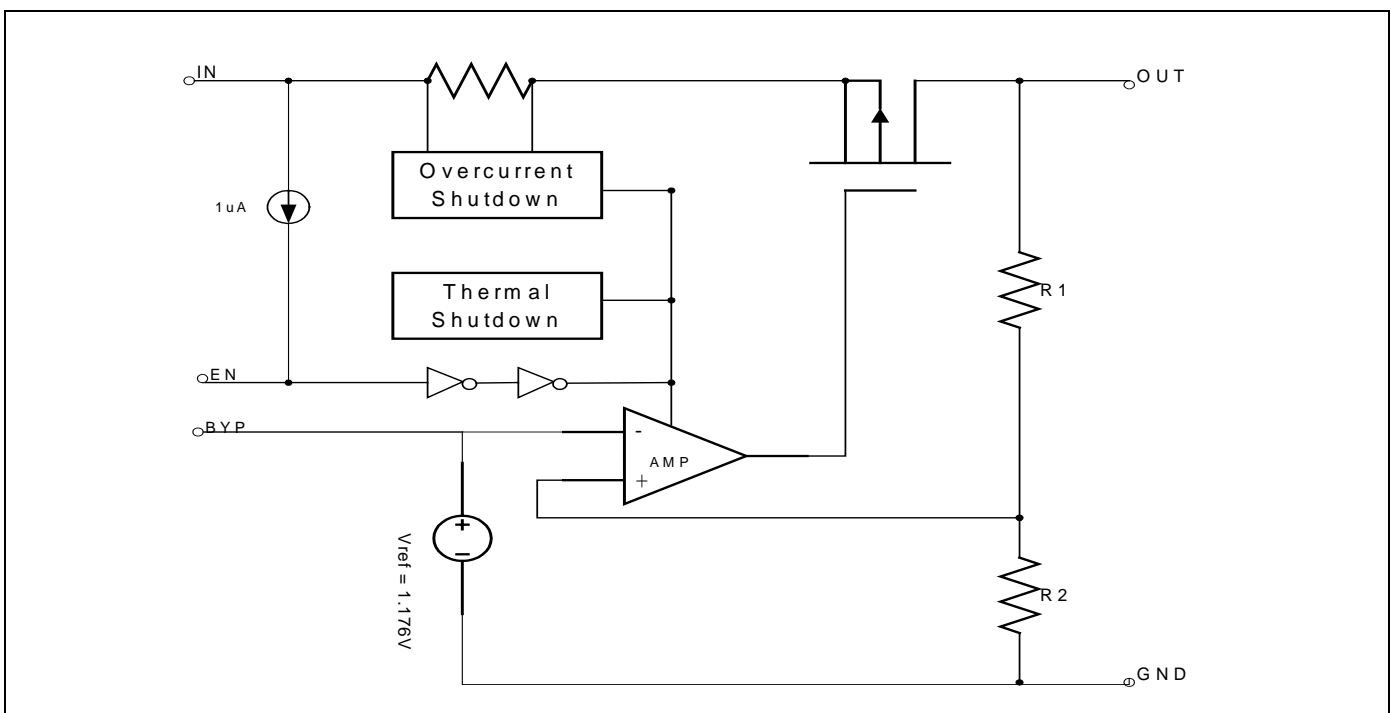



CM2836/B/C

300mA Low ESR CMOS LDO WITH ENABLE

ORDERING INFORMATION

Example:

Part Number	Output Voltage	Temperature Range	Package
CM2836/B/CGSIM23	3.3V	-40°C ~ +85°C	SOT-23
CM2836/B/CGSIM25	3.3V	-40°C ~ +85°C	SOT-23-5
CM2836/B/CGSIM89	3.3V	-40°C ~ +85°C	SOT-89
CM2836/B/CGSIM75	3.3V	-40°C ~ +85°C	SC70-5

Note: For other pre-set output voltage requirements, please contact Champion Sales office.
Please refer to page 10

ABSOLUTE MAXIMUM RATINGS

Input Voltage +7V
 Output Current $P_D / (V_{IN} - V_O)$ mA
 Output Voltage GND-0.3V to $V_{IN}+0.3V$
 ESD Classification B

OPERATING RATINGS

Ambient Temperature Range (T_A) -40°C to +85°C
 Junction Temperature Range -40°C to +150°C

THERMAL INFORMATION

Parameter	Package	Maximum	Unit
Thermal Resistance (θ_{jc})	SOT-23	160	°C/W
	SOT-23-5		
Thermal Resistance (θ_{jc})	SOT-89	100	°C/W
Thermal Resistance (θ_{jc})	SC70-5	250	°C/W
Internal Power Dissipation (P_D) ($\Delta T = 100^\circ C$)	SOT-23	250	mW
	SOT-23-5		
	SOT-89	400	mW
	SC70-5	200	mW
Maximum Junction Temperature		150	°C
Maximum Lead Temperature (10 Sec)		300	°C

Caution: Stress above the listed absolute rating may cause permanent damage to the device.



CM2836/B/C

300mA Low ESR CMOS LDO WITH ENABLE

ELECTRICAL CHARACTERISTICS

$T_A = +25^\circ\text{C}$; unless otherwise noted

Parameter	Symbol	Test Conditions	CM2836/B/C			Unit
			Min.	Typ.	Max.	
Input Voltage	V_{IN}		Note 1		7	V
Output Voltage Accuracy	V_{OUT}	$I_O = 1\text{mA to } 300\text{mA}$	-2		2	%
Dropout Voltage	$V_{DROPOUT}$	$I_O = 300\text{mA}$, $V_{OUT} = V_{O(NOM)} - 2\%$	$1.2\text{V} < V_{O(NOM)} \leq 2.0\text{V}$		1300	mV
			$2.0\text{V} < V_{O(NOM)} \leq 2.5\text{V}$		400	
			$2.5\text{V} < V_{O(NOM)}$		300	
Output Current	I_O	$V_{OUT} > 1.2\text{V}$	300			mA
Current Limit	I_{LIM}	$V_{OUT} > 1.2\text{V}$	300	450		mA
Short Circuit Current	I_{SC}	$V_O < 0.8\text{V}$		300	500	mA
Quiescent Current	I_Q	$I_O = 0\text{mA}$		30	35	μA
Ground Pin Current	I_{GND}	$I_O = 1\text{mA to } 300\text{mA}$		30	50	μA
Line Regulation	REG_{LINE}	$I_{OUT} = 5\text{mA}$, $V_{IN} = V_{OUT} + 1$ to $V_{OUT} + 2$	-0.1	0.02	0.1	%
Load Regulation	REG_{LOAD}	$I_O = 1\text{mA to } 300\text{mA}$		0.2	1	%
Over Temperature Shutdown	OTS			150		$^\circ\text{C}$
Over Temperature Hysteresis	OTH			30		$^\circ\text{C}$
V_{OUT} Temperature Coefficient	TC			40		ppm/ $^\circ\text{C}$
Power Supply Rejection (Sot23-3/Sot-89)	PSRR	$I_O = 100\text{mA}$ $C_O = 2.2\mu\text{F}$ ceramic	$f = 1\text{kHz}$		60	dB
			$f = 10\text{kHz}$		50	
			$f = 100\text{kHz}$		40	
Power Supply Rejection (Sot23-5/SC70-5)	PSRR	$I_O = 100\text{mA}$ $C_O = 2.2\mu\text{F}$ ceramic $C_{BYP} = 0.01\mu\text{F}$	$f = 1\text{kHz}$		65	dB
			$f = 10\text{kHz}$		45	
			$f = 100\text{kHz}$		25	
Output Voltage Noise (Sot23-3/Sot-89)	eN	$f = 10\text{Hz to } 100\text{kHz}$ $I_O = 10\text{mA}$, $C_{BYP} = 0\mu\text{F}$	$C_O = 2.2\mu\text{F}$		30	μVrms
			$C_O = 100\mu\text{F}$		20	
Output Voltage Noise (Sot23-5/SC70-5)	eN	$f = 10\text{Hz to } 100\text{kHz}$ $I_O = 10\text{mA}$, $C_{BYP} = 0.01\mu\text{F}$	$C_O = 2.2\mu\text{F}$		30	μVrms
			$C_O = 100\mu\text{F}$		20	
Shutdown Supply Current	I_{SD}	$V_{IN} = 5.0\text{V}$, $V_{OUT} = 0\text{V}$, $V_{EN} < V_{EL}$		0.2	2.0	μA
EN Input Bias Current	I_{EH}	$V_{EN} = V_{IN}$, $V_{IN} = 2.6\text{V to } 7\text{V}$			0.1	μA
	I_{EL}	$V_{EN} = 0$, $V_{IN} = 2.6\text{V to } 7\text{V}$		0.2	2.0	μA
EN Input Threshold	V_{EH}	$V_{IN} = 2.6\text{V to } 7\text{V}$	2		V_{IN}	V
	V_{EL}	$V_{IN} = 2.6\text{V to } 7\text{V}$	0		0.4	V

Note 1. $V_{IN(MIN)} = V_{OUT} + V_{DROPOUT}$

Note 2. The input voltage should be better applied before a current source load is applied to avoid start up problem.



DETAILED DESCRIPTION

The CM2836/B/C family of CMOS regulators contains a PMOS pass transistor, voltage reference, error amplifier, over-current protection, output short protection, and thermal shutdown.

The P-channel pass transistor receives data from the error amplifier, over-current protection, output short protection, and thermal protection circuits. During normal operation, the error amplifier compares the output voltage to a precision reference. Over-current and Thermal shutdown circuits become active when the junction temperature exceeds 150°C, or the current exceeds 300mA. During thermal shutdown, the output voltage remains low. Normal operation is restored when the junction temperature drops below 120°C.

The CM2836/B/C switches from voltage mode to current mode when the load exceeds the rated output current. This prevents over-stress.

ENABLE

The Enable pin normally floats high. When actively, pulled low, the PMOS pass transistor shut off, and all internal circuits are powered down. In this state, the quiescent current is less than 2μA. This pin behaves much like an electronic switch.

EXTERNAL CAPACITOR

The CM2836/B/C is stable with a Low ESR output capacitor to ground of 1.0μF or greater. It can keep stable even with higher ESR capacitors. A second capacitor is recommended between the input and ground to stabilize VIN. The input capacitor should be larger than 1μF to have a beneficial effect. All capacitors should be placed in close proximity to the pins. A “quiet” ground termination is desirable.

TYPICAL CHARACTERISTICS

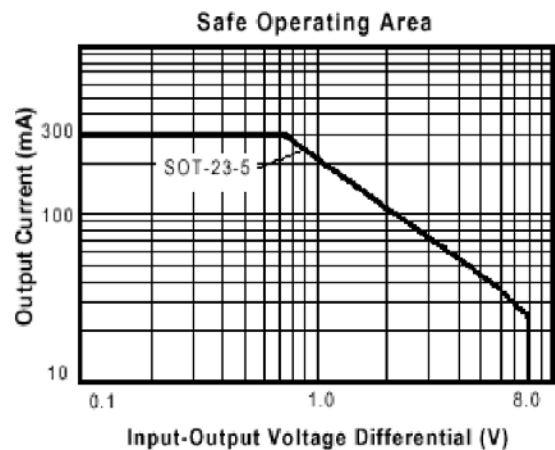
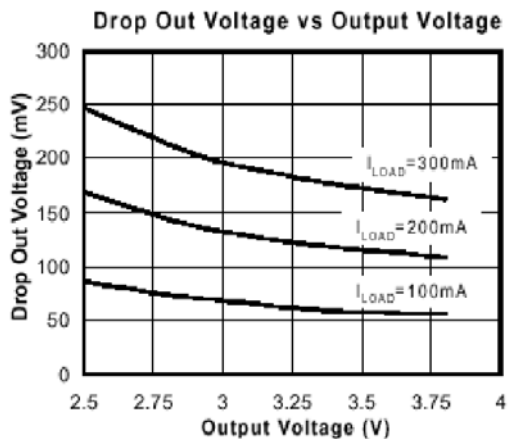
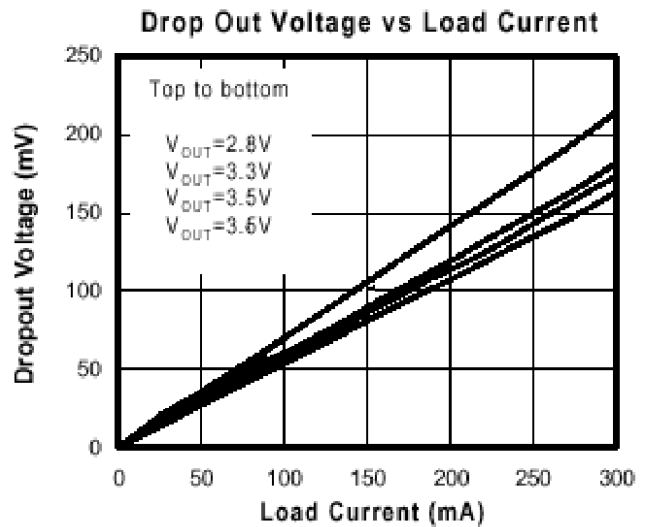
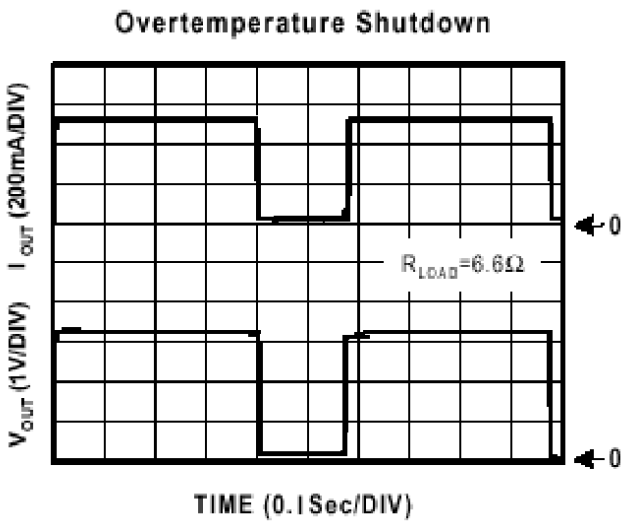
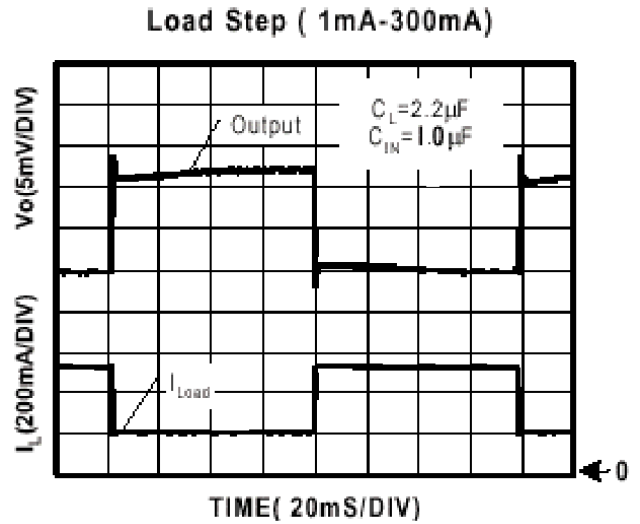
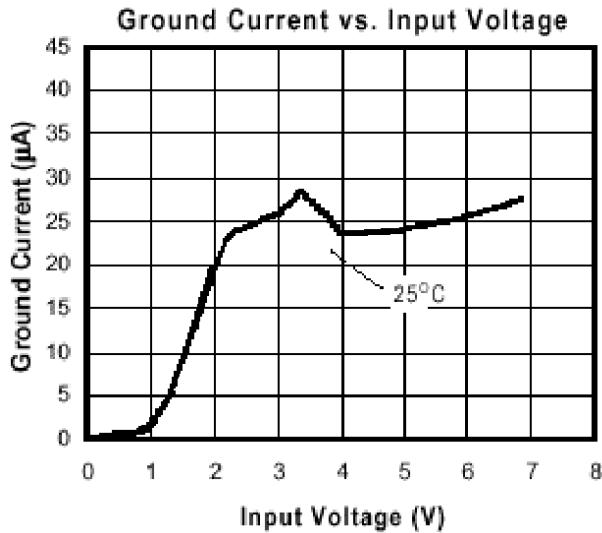

Chip Enable Transient Response

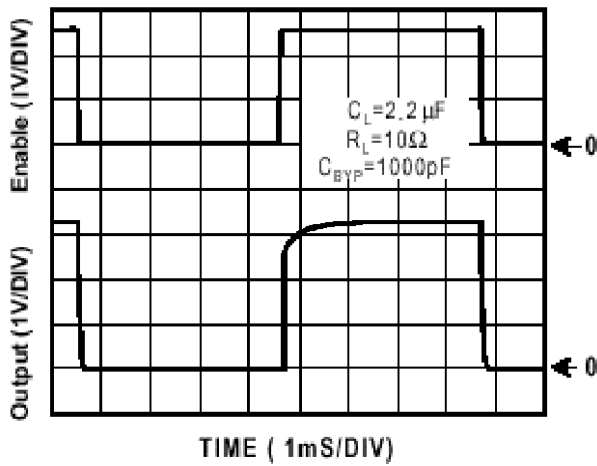

Chip Enable Transient Response

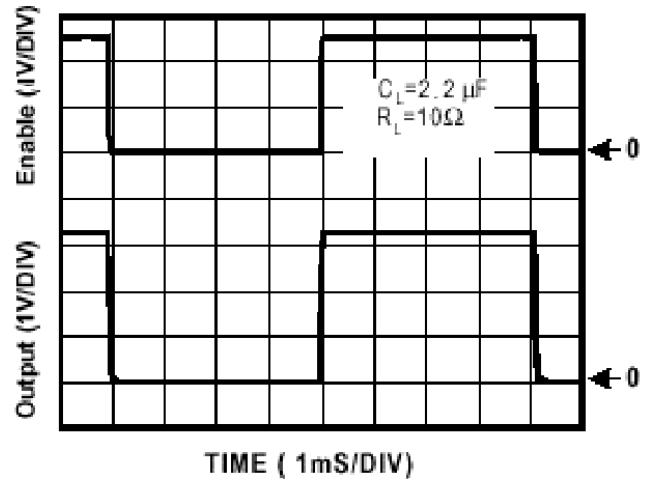

Power Supply Rejection Ratio

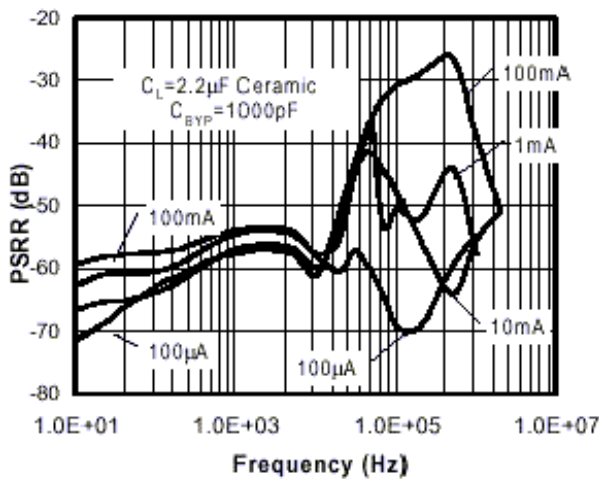

Power Supply Rejection Ratio

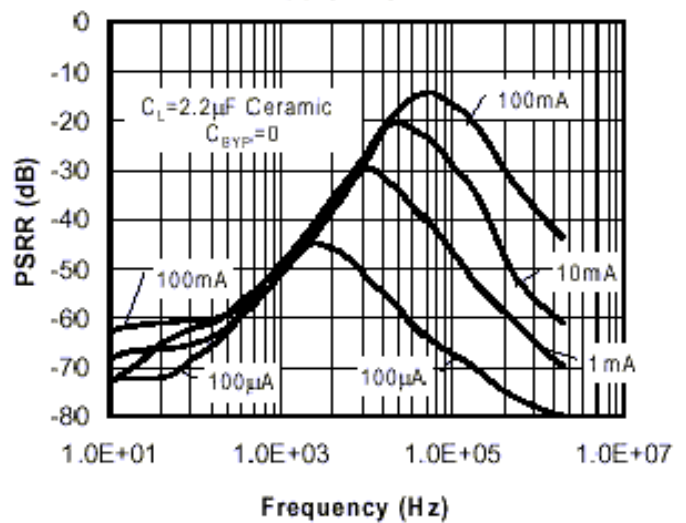

Current Limit Response

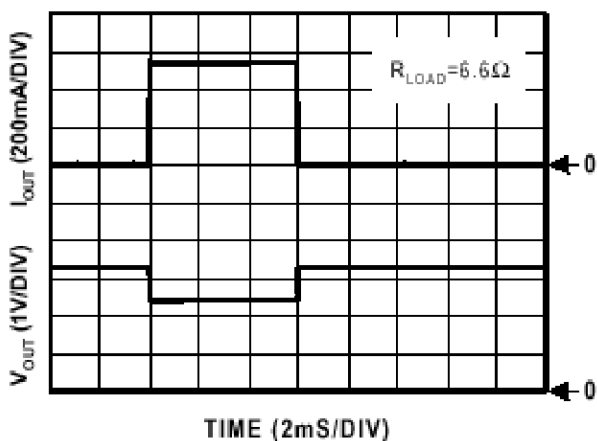

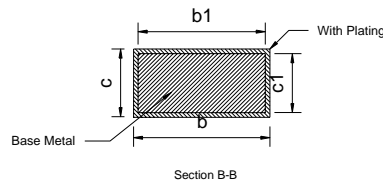
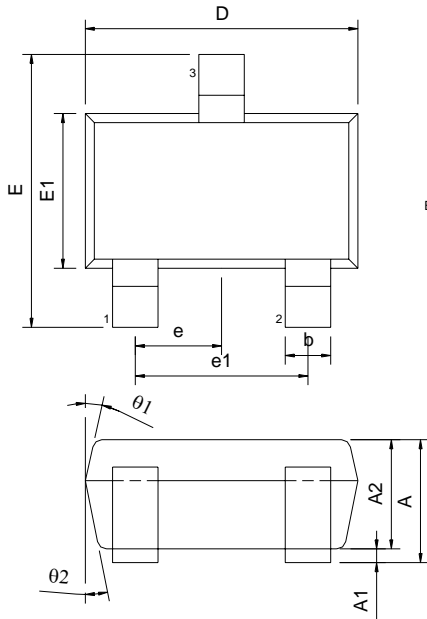
PACKAGE DIMENSION
SOT-23 (M23)

SYMBOLS	DIMENSIONS IN MILLIMETERS			DIMENSIONS IN INCHS		
	MIN	NOM	MAX	MIN	NOM	MAX
A	1.05	---	1.35	0.041	---	0.053
A1	0.05	---	0.15	0.002	---	0.006
A2	1.00	1.10	1.20	0.039	0.043	0.047
b	0.25	---	0.50	0.010	---	0.020
b1	0.25	0.40	0.45	0.010	0.016	0.018
c	0.08	---	0.20	0.003	---	0.008
c1	0.08	0.11	0.15	0.003	0.004	0.006
D	2.70	2.90	3.00	0.106	0.114	0.118
E	2.60	2.80	3.00	0.102	0.110	0.118
E1	1.50	1.60	1.70	0.059	0.063	0.067
L	0.35	0.45	0.55	0.014	0.018	0.022
L1	0.60 REF			0.024 REF		
e	0.95 BSC			0.037 BSC		
e1	1.90 BSC			0.075 BSC		
θ	0°	5°	10°	0°	5°	10°
θ1	3°	5°	7°	3°	5°	7°
θ2	6°	8°	10°	6°	8°	10°

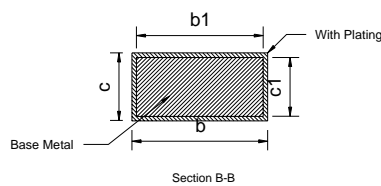
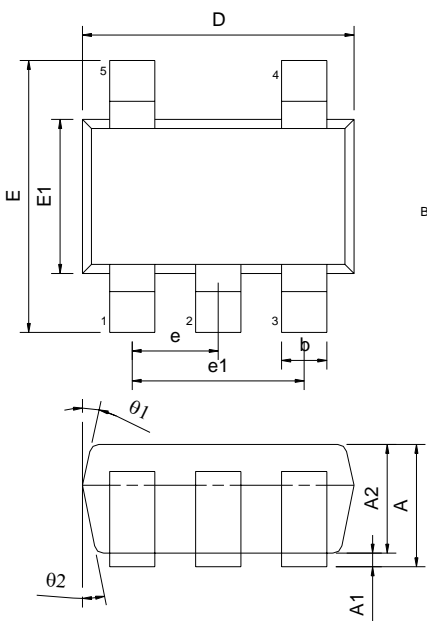
SOT-23-5 (M25)

SYMBOLS	DIMENSIONS IN MILLIMETERS			DIMENSIONS IN INCHS		
	MIN	NOM	MAX	MIN	NOM	MAX
A	1.05	---	1.35	0.041	---	0.053
A1	0.05	---	0.15	0.002	---	0.006
A2	1.00	1.10	1.20	0.039	0.043	0.047
b	0.25	---	0.50	0.010	---	0.020
b1	0.25	0.40	0.45	0.010	0.016	0.018
c	0.08	---	0.20	0.003	---	0.008
c1	0.08	0.11	0.15	0.003	0.004	0.006
D	2.70	2.90	3.00	0.106	0.114	0.118
E	2.60	2.80	3.00	0.102	0.110	0.118
E1	1.50	1.60	1.70	0.059	0.063	0.067
L	0.35	0.45	0.55	0.014	0.018	0.022
L1	0.60 REF			0.024 REF		
e	0.95 BSC			0.037 BSC		
e1	1.90 BSC			0.075 BSC		
θ	0°	5°	10°	0°	5°	10°
θ1	3°	5°	7°	3°	5°	7°
θ2	6°	8°	10°	6°	8°	10°

SOT-89 (M89)

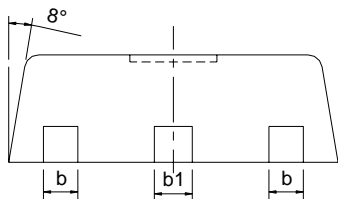
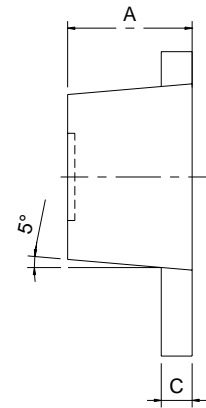
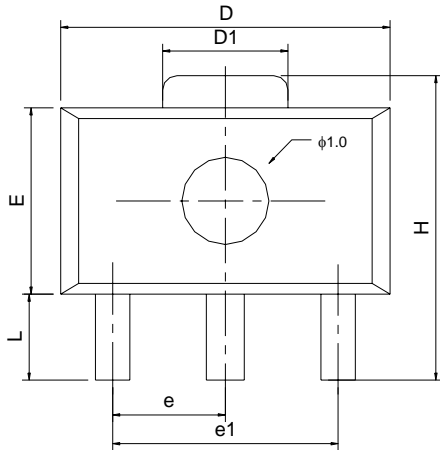

SYMBOLS	DIMENSIONS IN MILLIMETERS			DIMENSIONS IN INCHES		
	MIN	NOM	MAX	MIN	NOM	MAX
A	1.40	1.50	1.60	0.055	0.059	0.063
L	0.80	---	1.20	0.031	---	0.047
b	0.36	0.42	0.48	0.014	0.016	0.018
b1	0.41	0.47	0.53	0.016	0.018	0.020
C	0.38	0.40	0.43	0.014	0.015	0.017
D	4.40	4.50	4.60	0.173	0.177	0.181
D1	1.40	1.60	1.75	0.055	0.062	0.069
H	3.94	---	4.25	0.155	---	0.167
E	2.40	2.50	2.60	0.094	0.099	0.102
e1	2.90	3.00	3.10	0.114	0.118	0.122
e	1.45	1.50	1.55	0.057	0.059	0.061

SC70-5

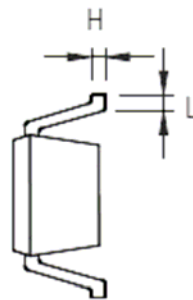
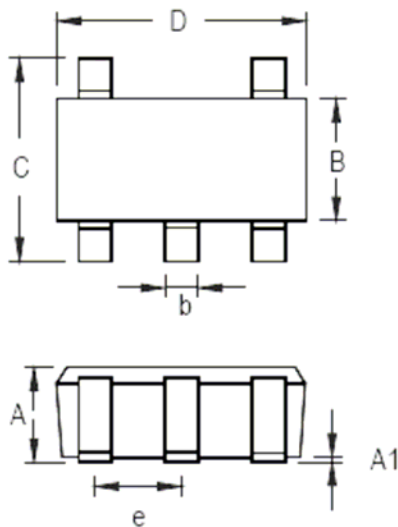

Symbol	Dimensions In Millimeters		Dimensions In Inches	
	Min	Max	Min	Max
A	0.800	1.100	0.031	0.044
A1	0.000	0.100	0.000	0.004
B	1.150	1.350	0.045	0.054
b	0.150	0.400	0.006	0.016
C	1.800	2.450	0.071	0.096
D	1.800	2.250	0.071	0.089
e	0.650		0.026	
H	0.080	0.260	0.003	0.010
L	0.210	0.460	0.008	0.018



CM2836/B/C

300mA Low ESR CMOS LDO WITH ENABLE

NUMBERING SCHEME

Ordering Number: CM2836/B/CXYZ (note1)

Ordering Number: CM2836/B/CGXYZ (note2)

note1:

CM2836/B/C: 300mA CMOS LDO with enable

X: Suffix for voltage output (note 3)

Y: Suffix for Temperature Range (note 4)

Z: Suffix for Package Type (note 5)

note2:

CM2836/B/C: 300mA CMOS LDO with enable

G: Suffix for Pb Free Product

X: Suffix for voltage output (note 3)

Y: Suffix for Temperature Range (note 4)

Z: Suffix for Package Type (note 5)

note 3: see CMOS LDO Voltage Suffix Table

CMOS LDO Voltage Suffix Table

Output Voltage	Suffix	Output Voltage	Suffix
1.2V	AC	2.5V	K
1.5V	A	2.6V	L
1.7V	C	2.7V	M
1.8V	D	2.8V	N
2.0V	F	3.0V	P
2.1V	G	3.1V	Q
2.2V	H	3.3V	S
2.3V	I	3.6V	V

note 4:

Y= I : -40°C~+85°C (only I grade support for all CMOS LDOs)

note 5:

Z is single alphabet with or without digits

M25 : SOT-23-5 (TR only)

M23 : SOT-23 (TR only)

M89 : SOT-89 (TR only)

SC70-5 (TR only)



IMPORTANT NOTICE

Champion Microelectronic Corporation (CMC) reserves the right to make changes to its products or to discontinue any integrated circuit product or service without notice, and advises its customers to obtain the latest version of relevant information to verify, before placing orders, that the information being relied on is current.

A few applications using integrated circuit products may involve potential risks of death, personal injury, or severe property or environmental damage. CMC integrated circuit products are not designed, intended, authorized, or warranted to be suitable for use in life-support applications, devices or systems or other critical applications. Use of CMC products in such applications is understood to be fully at the risk of the customer. In order to minimize risks associated with the customer's applications, the customer should provide adequate design and operating safeguards.

HsinChu Headquarter

5F, No. 11, Park Avenue II,
Science-Based Industrial Park,
HsinChu City, Taiwan
TEL: +886-3-567 9979
FAX: +886-3-567 9909

Sales & Marketing

7F-6, No.32, Sec. 1, Chenggong Rd., Nangang
District, Taipei City 115, Taiwan
TEL: +886-2-2788 0558
FAX: +886-2-2788 2985
