

Two Group, 3 and 3, WLED Driver, Different Current Settings

Features

- 2.9V to 6V input voltage range
- Powers two display backlight and/or flash WLEDs
- Low external parts count, requires no inductor and ballast resistors
- Low EMI and reflected ripple
- Adaptive charge pump ratio (1x or 1.5x) maximizes efficiency at both high and low input voltage
- Precision current regulation for each output with 2% current matching at 20mA
- Programmable LED current via ISET1 and ISET2
- Independent Analog and PWM brightness control
- Independent current setting for each group
- Typical 500-kHz fixed switching frequency
- Supports up to 300mA, drives six LEDs regulated to 50mA each
- Less than 10µA shutdown current
- Over-current and over-temperature protection
- Short circuit protection with auto shutdown
- Undervoltage lockout
- Soft-start limits start-up inrush current
- TQFN-16 package
- Optional RoHS compliant lead free packaging

Applications

- Drive white LEDs for STN/TFT Color LCD backlighting
- Cell phones, PDAs, with multiple displays
- Digital Still Cameras
- Flash for DSC

Product Description

The CM9133 is an adaptive fractional switched capacitor (charge pump) regulator optimized for driving two groups, 3 and 3, of white LEDs. Each group features individual ON/OFF control and individually set current. Each LED's driver current is matched to within 2% for uniform intensity. It supports an input voltage range of 2.9V to 6V, with undervoltage lockout. A failure detection circuit prevents the loss of power when one or more LED's fail (short or open). Internal over-temperature and over-current management provide short circuit protection.

The CM9133 regulates up to 300mA of output current to drive WLEDs, allowing up to 50mA per LED channel. The maximum LED current for each group is programmed with external resistors. Master plus two independent enable inputs, allows for Analog and PWM brightness control for each display. Either display can also be used for a camera flash. In full shutdown mode, the CM9133 draws only 10µA.

The CM9133 automatically selects the most efficient charge pump ratio based on the operating voltage requirement of the white LEDs. The proprietary design architecture maintains high efficiency (> 80%), and at low V_{IN} provides longer battery life. With a high V_{IN} , or when the adapter is powered, it provides cool reliable operation.

The CM9133 is available in a compact 16-pin TQFN package. It can operate over the industrial temperature range of -40°C to 85°C.

Typical Application

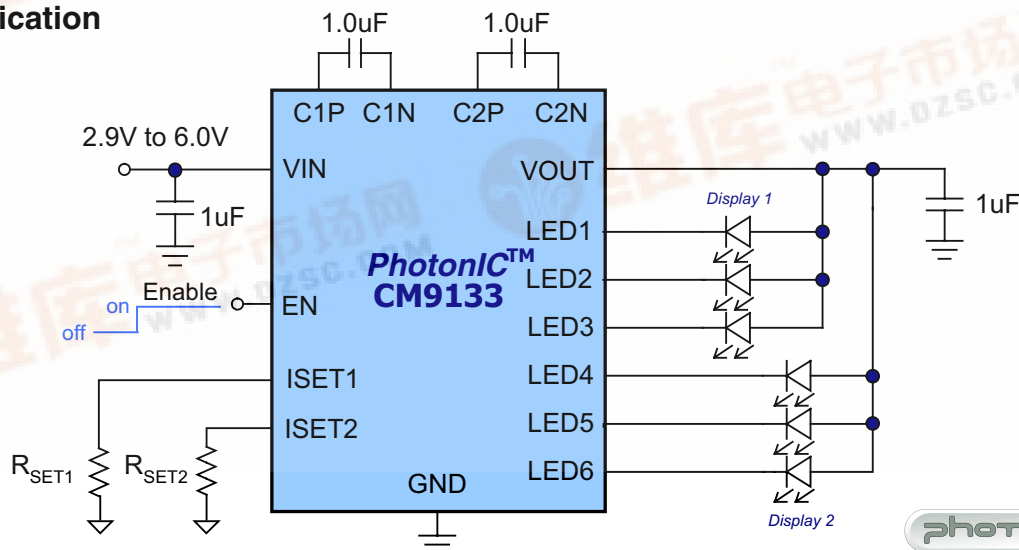

Package Pinout

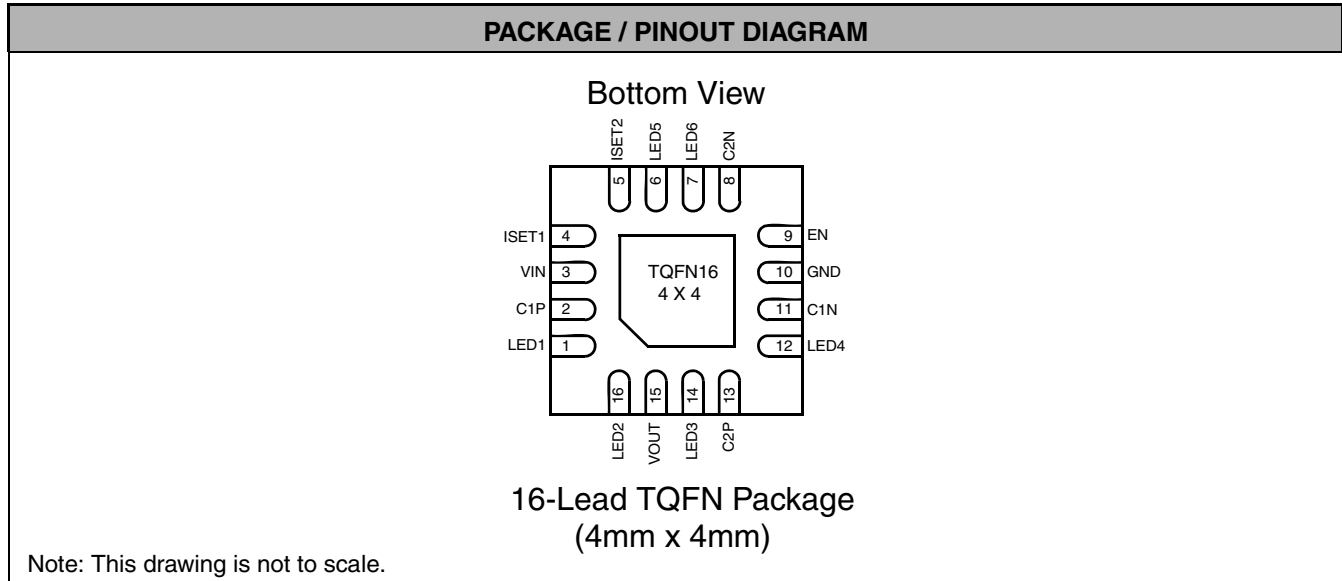

Ordering Information

PART NUMBERING INFORMATION			
Leads	Package	Lead-free Finish	
		Ordering Part Number ¹	Part Marking
16	TQFN	CM9133-01QE	

Note 1: Parts are shipped in Tape & Reel form unless otherwise specified.

Specifications

ABSOLUTE MAXIMUM RATINGS		
PARAMETER	RATING	UNITS
ESD Protection (HBM)	± 2	kV
Pin Voltages		
V_{IN} to GND	[GND - 0.3] to +6.0	V
V_{OUT} to GND	[GND - 0.3] to +7.0	V
ISET1, ISET2, EN to GND	[GND - 0.3] to +5.0	V
All other pins to GND	[GND - 0.3] to +5.0	
Storage Temperature Range	-65 to +150	°C
Operating Temperature Range	-40 to +85	°C
Lead Temperature (Soldering, 10s)	300	°C



Specifications (cont'd)

ELECTRICAL OPERATING CHARACTERISTICS $V_{IN} = 3.6V$; All outputs are on. Typical values are at $T_A = 25^\circ C$.

SYMBOL	PARAMETER	CONDITIONS	MIN	TYP	MAX	UNIT
V_{IN}	Supply Voltage Range		2.9		6.0	V
V_{UVLO}	Undervoltage Lockout	All outputs are no load.	1.7	1.8	1.9	V
I_Q	Quiescent Current	1x mode		500		μA
I_{SD}	Shutdown Supply Current	$V_{EN} < 0.4V$		2	10	μA
VOU Charge Pump						
V_{OUT}	Output Voltage	$I_{OUT} = 0mA$ to 120mA, $V_{IN} = 3.0$ to 5.5V	4.2		5.5	V
$I_{LED\ TOT}$	Total I_{LED} Current	ΣI_{LED1} thru I_{LED4} +photoflash			300	mA
ILED						
	Accuracy of ISET	$V_{IN} = 3.0V$ to 5.5V		1		%
	Matching current between LED1 to LED6	$V_{IN} = 4.0V$, I_{LED1} to $I_{LED6} = 20mA$		2	5	%
	I_{LED} per driver	Device total $I_{LED} < 300mA$			50	mA
EN, ISET						
V_{IH}	High Level Input Voltage		1.8			
V_{IL}	Low Level Input Voltage				0.4	
Protection						
	Over-current Limit			400		mA
	Over-temperature Limit			135		$^\circ C$
	Over-temperature Hysteresis			15		$^\circ C$

Typical Performance Curves

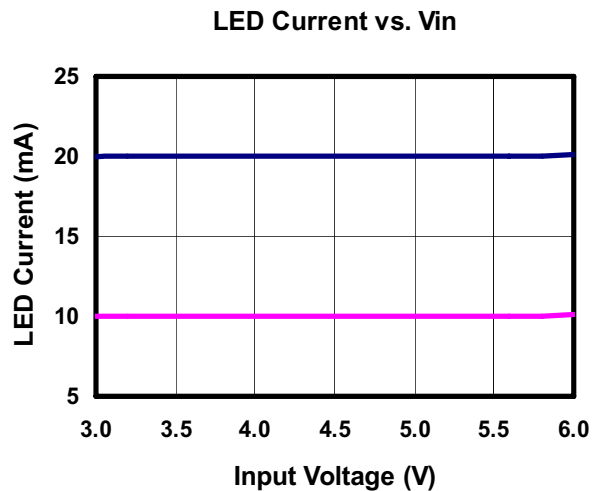
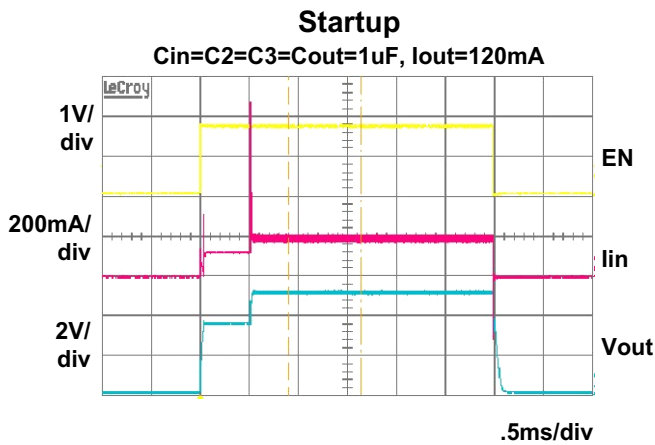
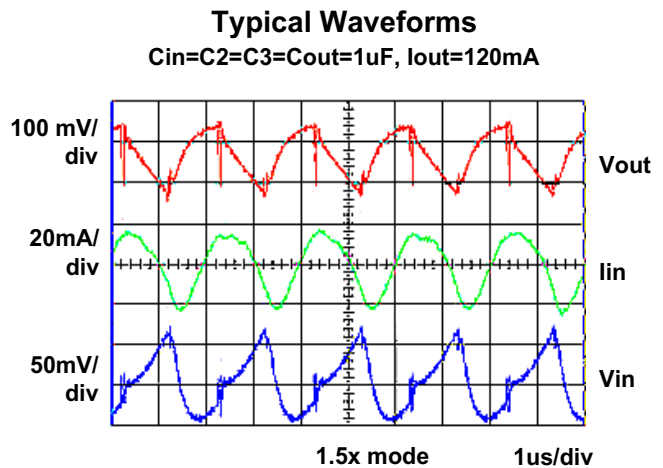
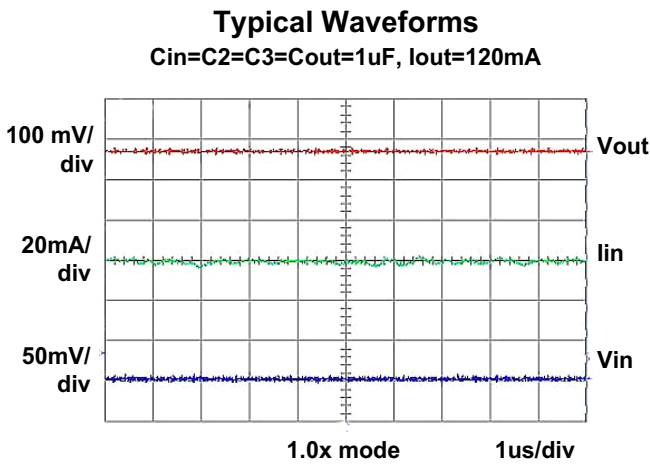
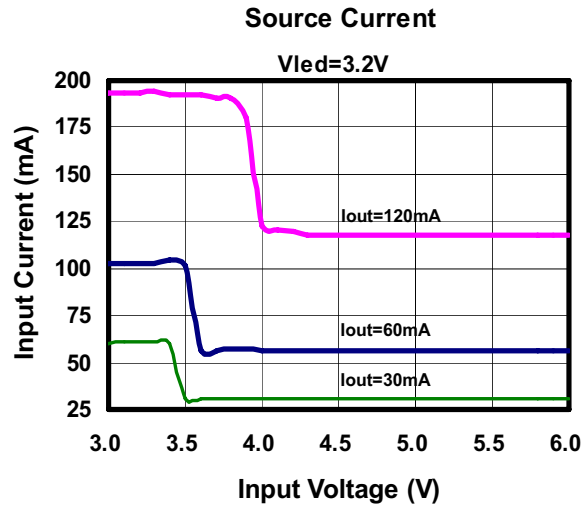
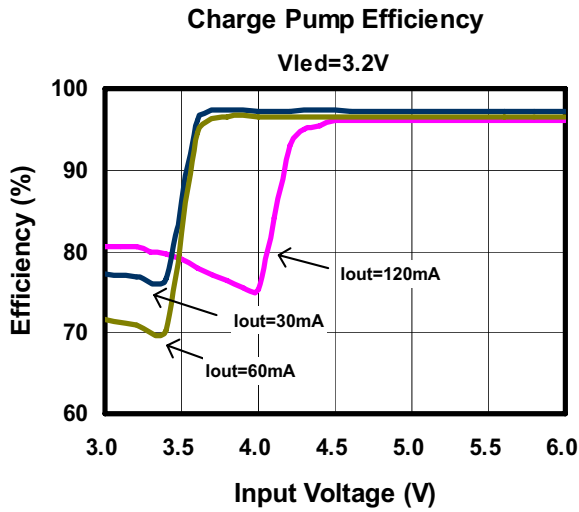

Functional Block Diagram

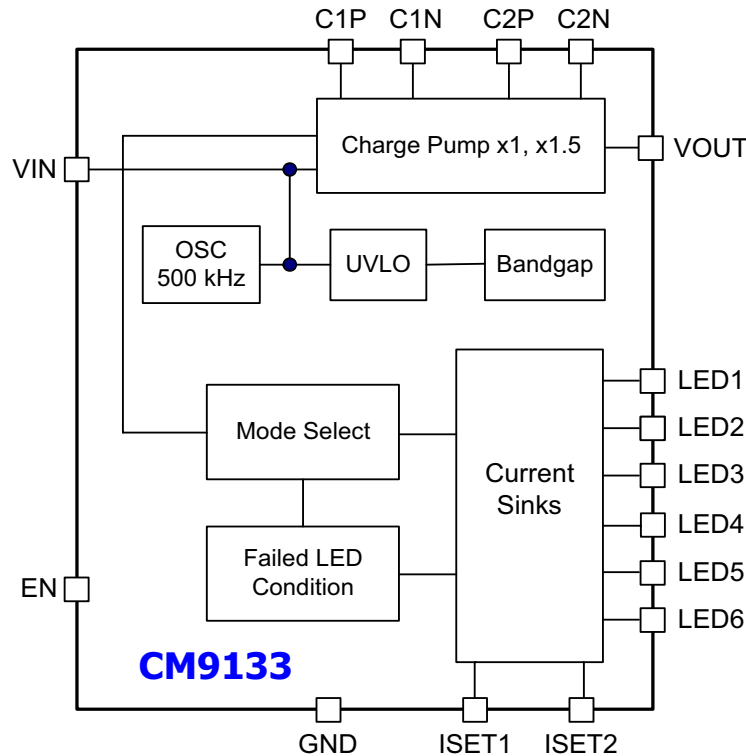

Pin Descriptions

PIN DESCRIPTIONS		
LEAD(s)	NAME	DESCRIPTION
1	LED1	Cathode of LED1 pin.
2	C1P	This pin is the plus side of charge pump bucket capacitor C1. Connect a 1.0μF ceramic capacitor with a voltage rating of 10V or greater between C1N and C1P.
3	VIN	Positive supply voltage input pin. This voltage should be between 2.9V and 6V. This pin requires a 1.0μF or larger ceramic capacitor to ground.
4	ISET1	<p>Current set and shutdown pin for drivers, active low. Pull high to shutdown the group.</p> <p>To set the LED current, a resistor, R_{SET}, is connected between this pin and ground. The regulated LED current is 1000x the current flowing in R_{SET}, and is approximately:</p> $I_{LED} = \frac{0.66V - (\text{LogicLow})}{R_{SET}} \times 1000$ <p>If this resistor is tied to directly ground (and enable function not used) Logic Low = 0, otherwise subtract the voltage drop of the device that drives this pin low.</p>

Pin Descriptions (cont'd)

PIN DESCRIPTIONS		
5	ISET2	<p>Current set and shutdown pin for drivers, active low. Pull high to shutdown the group.</p> <p>To set the LED current, a resistor, R_{SET}, is connected between this pin and ground. The regulated LED current is 1000x the current flowing in R_{SET}, and is approximately:</p> $I_{LED} = \frac{0.66V - (\text{LogicLow})}{R_{SET}} \times 1000$ <p>If this resistor is tied to directly ground (and enable function not used) Logic Low = 0, otherwise subtract the voltage drop of the device that drives this pin low.</p>
6	LED5	Cathode of LED5 pin.
7	LED6	Cathode of LED6 pin.
8	C2N	This pin is the minus side of charge pump bucket capacitor C2. Connect a 1.0 μ F ceramic capacitor between C2N and C2P.
9	EN	PWM/Analog input pin. Can be used as second Enable pin, active high. Should tied high when not used.
10	GND	Ground terminal pin.
11	C1N	This pin is the minus side of charge pump bucket capacitor C1. Connect a 1.0 μ F ceramic capacitor between C1N and C1P.
12	LED4	Cathode of LED4 pin.
13	C2P	This pin is the plus side of charge pump bucket capacitor C2. Connect a 1.0 μ F ceramic capacitor between C2N and C2P.
14	LED3	Cathode of LED3 pin.
15	VOUT	Charge pump output voltage pin, which connects to the anodes of all LEDs. A 1 μ F capacitor to ground is recommended.
16	LED2	Cathode of LED2 pin.

Application Information

The CM9133 is a switched capacitor, charge pump voltage converter ideally suited for driving white LEDs to backlight LCD color displays in portable devices. The CM9133 charge pump is the perfect driver for portable applications such as cellular phones, digital still cameras, PDAs and any application where small space, compact overall size, low system cost and minimal EMI are critical.

The CM9133 requires only two external switched (bucket) capacitors, plus an input and an output capacitor, providing for a compact, low profile design. In many applications, these can all be conveniently the same value of $1.0\mu\text{F}$, available in a compact 0805 surface mount package.

The adaptive conversion ratio selects the most efficient operating mode. When V_{IN} is higher than the needed V_{OUT} ($V_{\text{LED}} + V_{\text{CURRENT_SINK}}$), the 1x mode is set. When the input voltage is below the LED forward voltage and a voltage boost is needed, the 1.5x mode is automatically selected. The 1.5x mode uses a fractional charge pump to convert the nominal Li-ion battery voltage (3.6V) by 1.5 times and regulates the LED current to the low dropout current sources.

The current regulated sources maintain constant LED drive in the presence of supply voltage fluctuations. All LEDs are driven with the same current even when they have slightly different forward voltages. The individual current sources sense the current through each LED and match this current to less than 2% for uniform brightness across the color LCD display.

The CM9133 drives up to three WLEDs in group one and three WLEDs in the second group. The maximum current programmed by R_{SET} determines the maximum intensity of each group's display; the displays can be further dimmed by PWM control applied to its ISET1 or ISET 2 pin.

CM9133 Operation

When a voltage that exceeds the undervoltage lockout threshold (UVLO) is applied to the VIN pin, the CM9133 initiates a softstart cycle, typically lasting $100\mu\text{S}$. Softstart limits the inrush current while the output capacitors are charged. Following softstart, the CM9133 next determines the best conversion ratio (1x or 1.5x).

The 1.5x mode employs a fractional charge pump. The charge pump uses two phases from the internal oscillator to drive switches that are connected to the bucket capacitors, C1 and C2, as shown in Figure 1. In the first switch position, the bucket capacitors are connected in series and each are charged from V_{IN} to a voltage of $V_{\text{IN}}/2$. The next phase changes the switch positions so that C1 and C2 are in parallel, and places them on top of V_{IN} . The resulting voltage across C_{OUT} is then; $V_{\text{IN}} + 1/2V_{\text{IN}} = 1.5 \times V_{\text{IN}}$.

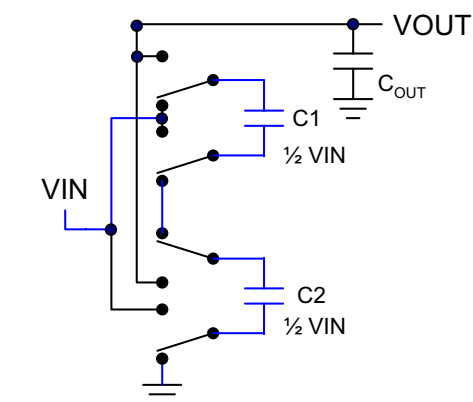

Charge C1 and C2 to $\frac{1}{2} V_{\text{IN}}$ each

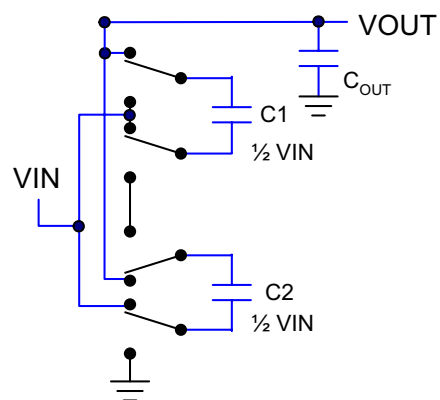

Transfer $\frac{1}{2} V_{\text{IN}}$ charge to top of VIN

Figure 1. Switch Operation

The CM9133 has over-temperature and over-current protection circuitry to limit device stress and failure during short circuit conditions. An overcurrent condition will limit the output current (approximately 400~600mA) and will cause the output voltage to drop, until automatically resetting after removal of the excessive current.

Application Information (cont'd)

Over-temperature protection disables the IC when the junction is about 135°C, and automatically turns on the IC when the junction temperature drops by approximately 15°C.

Efficiency

A conventional charge pump with a fixed gain of 2x will usually develop more voltage than is needed to drive paralleled white LEDs from Li-Ion sources. This excessive gain develops a higher internal voltage, reducing the system efficiency and increasing battery drain in portable devices. A fractional charge pump with a gain of 1.5x is better suited for driving white LEDs in these applications.

The CM9133 charge pump automatically switches between the two conversion gains, 1x and 1.5x, allowing high efficiency levels over a wide operating input voltage range. The 1x mode allows the voltage to pass directly through to the output when sufficient input voltage is available. As the battery discharges to the point where any one current source no longer has sufficient voltage headroom to maintain a constant current regulation, the 1.5x charge pump is enabled.

At nominal loads, the switching losses and quiescent current are negligible. If these losses are ignored for simplicity, the efficiency, η , for an ideal 1.5x charge pump can be expressed as the output power divided by the input power:

$$\eta = \frac{P_{LED}}{P_{IN}}$$

For an ideal 1.5x charge pump, $I_{IN} = 1.5 \times I_{OUT}$, and the efficiency may be expressed as:

$$V_{OUT} = (V_{LED} + V_{CURRENT_SINK})$$

$$\frac{P_{LED}}{P_{IN}} \approx \left(\frac{V_{OUT} \times I_{OUT}}{V_{IN} \times 1.5 \times I_{OUT}} \right) = \frac{V_{OUT}}{1.5 \times V_{IN}}$$

$$\text{For } (V_{LED} + V_{CURRENT_SINK}) = 3.9V, \quad \eta \approx \frac{3.9V}{1.5 \times V_{IN}}$$

Many charge pumps are fixed 2x designs. The ideal 2x charge pump efficiency can be similarly expressed;

$$\frac{P_{OUT}}{P_{IN}} \approx \frac{3.9V}{2.0 \times V_{IN}}$$

In 1x mode, when the input voltage is above the output voltage, the ideal efficiency is simply V_{OUT}/V_{IN} .

The typical conversion efficiency plots for these modes, with some losses, are shown in Figure 2.

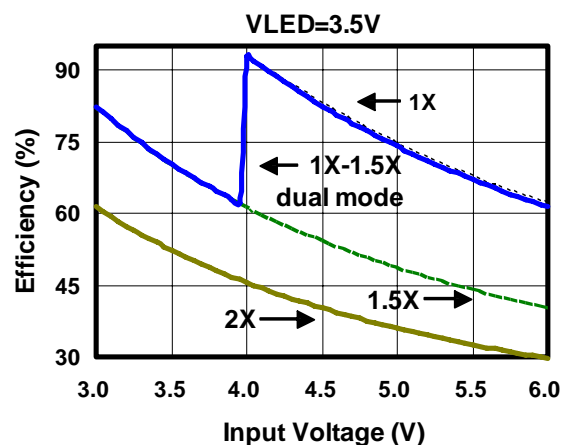

Figure 2. Ideal charge pump efficiency

As can be seen, the CM9133, with 1x and 1.5x modes, has better efficiency in this application than a fixed 2x charge pump. At low battery voltages, the higher efficiency of the CM9133 charge pump's 1.5x gain reduces the battery drain. At higher input voltages, typically seen when the system is running off an AC adapter, the CM9133, operating the 1x mode, has better efficiency than single mode 1.5x or 2x charge pumps, lowering the power dissipation for cooler circuit operation and long life.

While the charge pump efficiency is easily determined, the system efficiency is more difficult due to the current source outputs, which complicate measuring the output power. The forward voltage of the white LEDs will vary, and the constant current sources will adjust to maintain the current. When comparing systems, it is best to compare the input current for a specified LED drive current.

Application Information (cont'd)

The 1x mode has better efficiency than the 1.5x mode. Selecting LEDs with low forward voltage (V_{LED}) increases the time spent in the 1x mode as the battery discharges, extending the operating time.

Failed LED Detection

If a LED is shorted, the CM9133 will continue to operate and drive the remaining LEDs at the programmed current. If a LED opens, the other LEDs will still be regulated at the programmed current.

LED Current Set (ISET)

An external resistor programs a reference current, setting the maximum driver current. This resistor must be tied to a good analog ground. If it is pulled to ground through a switch, for example, from the host controller output, the voltage drop across that switch should not exceed 10mV.

The voltage at the ISET1 and ISET2 pins is provided by a .66V bandgap reference. The LED current is approximately 1000x the current set by the R_{SET} resistor, according to the following formula:

$$R_{SET} = \frac{0.66V - (\text{LogicLow})}{I_{LED}} \times 1000$$

Logic Low is the voltage on device driving this pin to ground. If the resistor is tied to ground directly, Logic low = 0. For 20mA LED current, $R_{SET} \approx 33$ k. When this pin is driven high or open, the device will enter a sleep mode with $V_{OUT} = 4.5V$ and, with no load, $I_{QUIESCENT} \approx 500\mu A$.

Analog Control of Display Intensity

Typically, portable devices control the backlight display intensity in response to ambient light conditions, or lower the intensity after a short standby interval to conserve battery charge. The luminous intensity of white LEDs is proportional to the amount of forward current through them, but the color wavelength emitted is also dependent upon the forward current. In applications where color shift is not critical, brightness can be controlled by adjusting the diode's current. A typical white LED Intensity vs. forward current curve is shown in Figure 3.

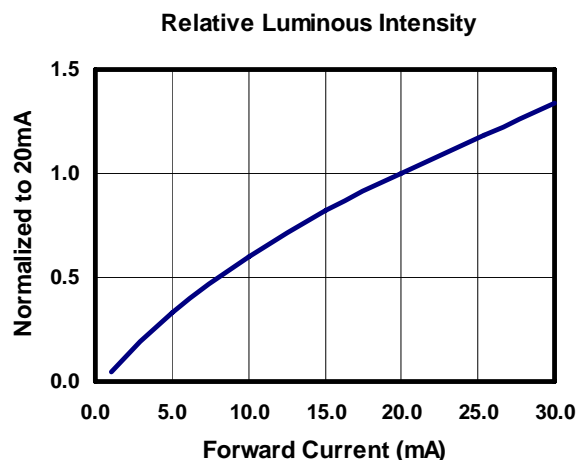

Figure 3. Typical Luminous Intensity vs. LED Current

The ISET pins of the CM9133 can be used to connect an analog DC signal for analog dimming of the white LEDs, as shown in Figure 4. This requires an additional resistor, R, and a DC source voltage, V_C .

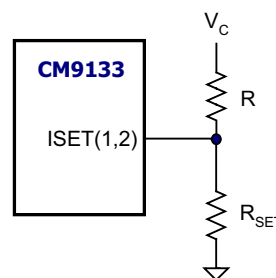

Figure 4. Analog LED current adjust

A control voltage, V_C , applied to the resistor divider will decrease the current for all LEDs. The maximum LED current occurs with 0V on V_C , which is set by R_P is the parallel combination of R and R_{SET} .

$$R_P = \frac{0.66V}{I_{LEDmax}} \times 1000$$

Choose the maximum control voltage, V_C , which sets zero LED current, and then determine the resistor ratio.

Application Information (cont'd)

$$\text{Ratio} = \frac{0.66\text{V}}{V_c - 0.66\text{V}}$$

The resistors can be determined from the equations below.

$$R = \frac{(R \times \text{Ratio}) + R_p}{\text{Ratio}}$$

$$R_{\text{set}} = \text{Ratio} \times R$$

For example, a V_c max of 2.5V and a maximum current setting of 20mA, $R=125\text{k}$, $R_{\text{SET}}=44.8\text{k}$. Figure 5 shows the control curve.

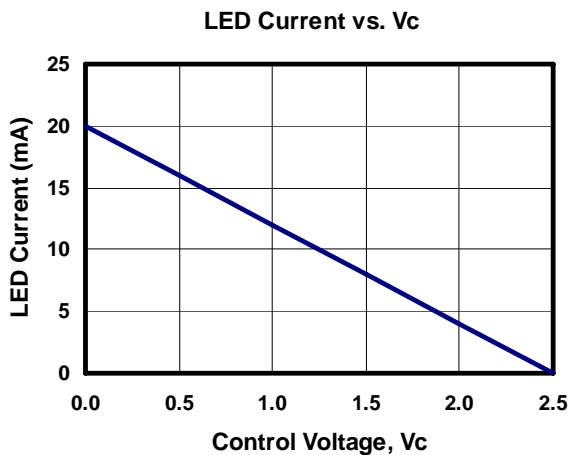

Figure 5. LED Current Control Curve

The circuit in Figure 6 is an example of logic dimming control, which changes the LED forward current in discrete steps. The NMOS source is an open drain (or open collector if bipolar) device, either the output of a host controller, or a discrete device. Open drain, or open collector devices sink current in their active, low voltage state (logic 0), and are high impedance in their high voltage, non-active state (logic 1). The open drain must not be pulled high with an external resistor, but instead connected only to the current setting resistors.

The parallel combination of R and R_{SET} determine the full intensity current. When the drain goes high, R_{SET} determines the lower intensity current.

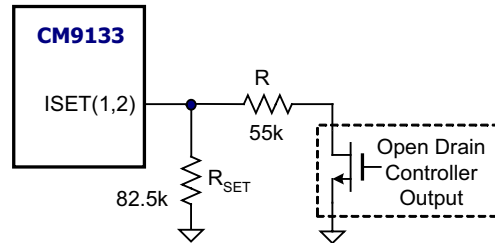

Figure 6. Logic Signal Dimming

For example, to reduce the luminosity intensity by half, using the LED curve from Figure 3, the current setting needs to be changed from 20mA to about 8mA. The values in Figure 6 will accomplish this, are where obtained using the following equations;

$$R_p = \frac{.66\text{V} * 1000}{I_{\text{LED}}(\text{max})} \quad R_{\text{set}} = \frac{.66\text{V} * 1000}{I_{\text{LED}}(\text{min})}$$

$$R = \frac{1}{\frac{1}{R_p} - \frac{1}{R_{\text{set}}}}$$

Additional parallel resistors can be added in the same way.

PWM Control of Display Intensity

Typically, portable devices control the backlight display intensity in response to ambient light conditions, or lower the intensity after a short standby interval to conserve battery charge. The CM9133 allows the output to lower the LED brightness by applying a pulsing (PWM) signal to EN, as shown in Figure 7 for group 2. The waveforms are shown in Figure 8.

The white in white LEDs is typically bichromatic, produced by a blue or UV LED that excites yellow phosphors. The two colors combine and the human eye sees these them as white light. The forward current of the LED influences the chromaticity, with higher LED current increasing the blue content of the color.

Using a PWM signal allows the LEDs to be dimmed without substantially shifting their color balance due to chromaticity shifts related to changing white LED forward current. The PWM signal causes the LEDs to

Application Information (cont'd)

operate either at the full ISET current, or at zero current. Only the time averaged current changes. Above a minimum frequency, the human eye will perceive the change in duty cycle as a change in brightness.

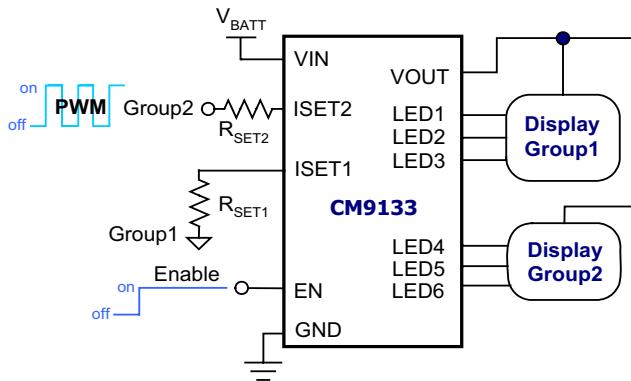

Figure 7. PWM applied to Group 2

The recommended frequency is between 100 Hz and 200 Hz, with a duty cycle greater than 20%. If a frequency of less than 100 Hz is used, flicker might be seen in the LEDs. The frequency should also be greater than the refresh rate of the TFT display. Higher frequencies will cause a loss of the brightness control linearity. In addition, higher frequency can cause chromaticity shifts because the fixed rise and fall times of the PWM signal will shift the forward current.

The PWM signal will cause the average LED current to be reduced. The average current is determined by the PWM duty cycle, which can vary from 0% to 100%. Decreased Duty Cycle will linearly lower the LED brightness, 0% Duty Cycle will turn off the display LEDs.

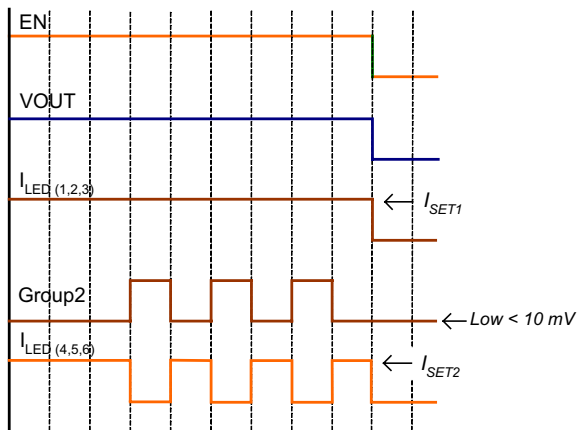

Figure 8. PWM Signal Dimming

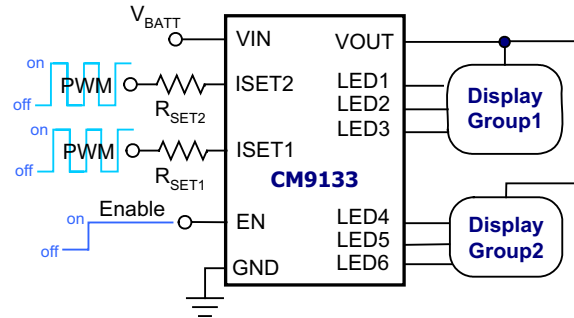

Figure 9. Separate PWM signals for each group

CM9133 Design Examples

Two-display cell phone

Typically, the mobile phone LCD displays (both STN and mini-TFT) require three to four white LEDs for backlighting, but as few as two of the newer high-brightness LEDs can be used. Lightguides are used to distribute the light uniformly behind the LCD. In this application, four white LEDs are used for the larger main display (inside the clamshell) and two for the sub-display.

A typical application for the CM9133 is a two-display clamshell phone, with an internal main display and an external sub-display typically used for caller ID and time of day, backlighting only when there is an incoming call. When the clamshell is opened, the sub-display backlight goes off and the main display backlight goes on. See Figure 10.

The either display's intensity can be lowered by a PWM signal applied to R_SET resistors for the host controller, as determine by the ambient light conditions.

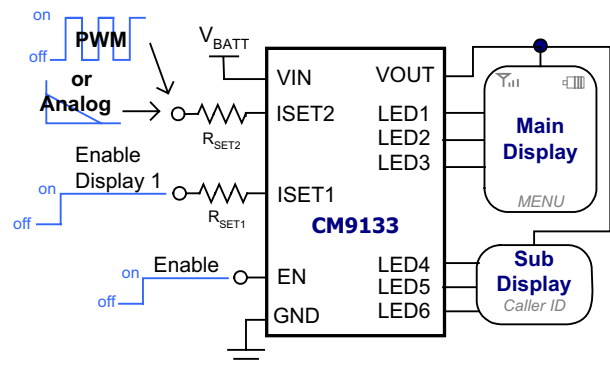

Figure 10. Clamshell Phone Application

Application Information (cont'd)

Phone with Keyboard Backlight

The CM9133 can support a wireless phone with LCD and a backlit keyboard. Group one can drive the backlight to the LCD, and group two drive the keyboard backlight. Each group can have a different current setting, and individual PWM signals applied. One or both groups can have their brightness controlled by a PWM signal. In the example in Figure 11, both are controlled with one PWM signal.

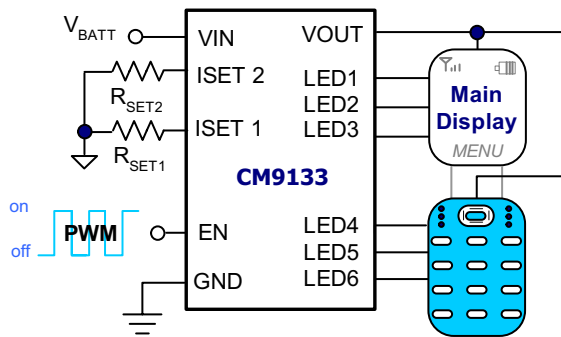

Figure 11. Phone with Keyboard Backlight

PDA Backlight

The CM9133 can support larger displays such as color LCDs for PDAs by utilizing both groups. Typically, larger displays will require four or more WLED backlights. With all the drivers set at the same current, a uniform backlighting can be achieved. EN can be used for ON/OFF control PWM dimming. Figure 12 shows a typical application.

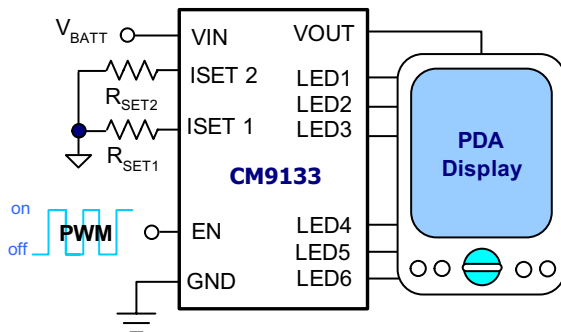

Figure 12. PDA Display Backlight

Camera Flash

The CM9133 can support a camera flash and a display in digital still cameras as well as in camera equipped smart phones and PDAs. A typical example would be the main display is supplied by group 2, and the outputs of group 1 are used to support flash white LEDs. See Figure 13. If less current is required for the Main display drivers in group two, it can be allocated to group one with the appropriate programming of the R_{SET} resistors.

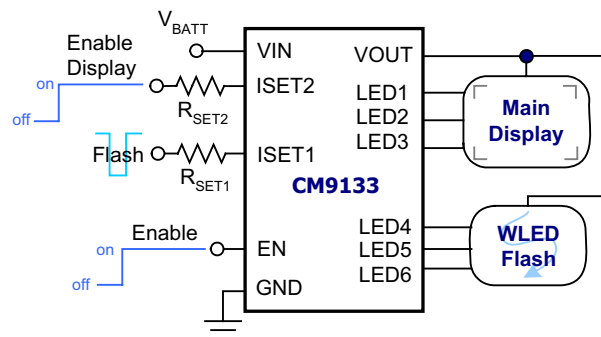

Figure 13. Display and Flash Application

If a full regulated flash current is needed both display outputs can be used to drive flash modules, as shown in Figure 14. In this case, EN controls the flash, enabling both outputs.

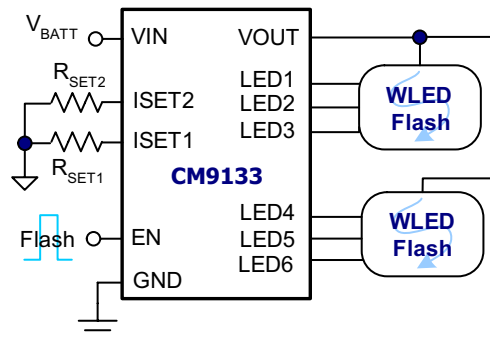

Figure 14. All Flash

Another option, which provides the maximum flash current, can be implemented by pulling the cathode of the flash LED to ground with a switch for the brief duration of the flash. The example shown in Figure 15 shows an example that allows the flash LED to be used as a torch light or a preview light in normal operation, and

Application Information (cont'd)

for full flash when the external switch is turned on. In this example, the main display intensity is controlled by two line inputs to ISET1, and the torch light is controlled by S1.

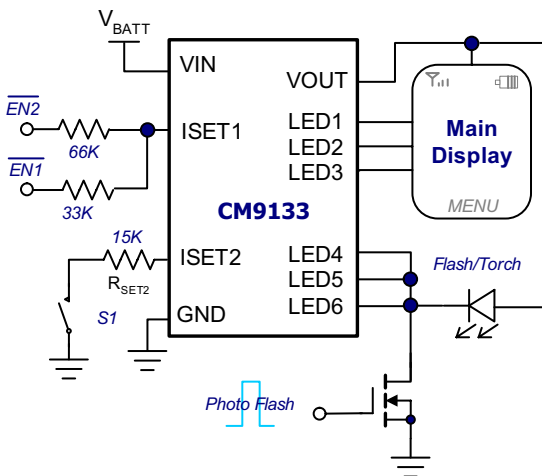

Figure 15. Display, Torch and Full Flash

Capacitor Selection

For proper performance, use surface-mount, low ESR ceramic capacitors for all four positions. X7R or X5R ceramic dielectric provides good stability over the operating temperature and voltage range,

The capacitance and ESR of the external bucket capacitors will directly affect the output impedance and efficiency of the converter. A ceramic 1 μ F capacitor is recommended.

Reflected input ripple depends on the impedance of the V_{IN} source, such as the PCB traces and the Li-ion battery, which has elevated impedance at higher frequencies. The input capacitor located near the converter input reduces this source impedance and ripple. Any ESR from the capacitor will result in steps and spikes in the ripple waveform, and possibly produce EMI. Much of the ripple voltage is due to moving current charge in and out of the capacitor and the capacitor's impedance at the charge pump frequency. If ripple voltage or current on the battery bus is application issue, add a small input inductor between the battery and the capacitor, or just increase the capacitor.

For a given output current, increasing the output capacitance reduces output ripple in the 1.5x mode.

Increasing the output capacitor will also increase start-up current and time. In most LED applications, high frequency output ripple is not a concern because it will not cause intensity variations that are visible to the human eye.

Layout Guide

The charge pump is rapidly changing and discharging the external capacitors, so external traces to the capacitors should be made wide and short to minimize inductance and high frequency ringing. The four capacitors should be located as close as practical to the charge pump, particularly C1 and C2, which have the highest dv/dt. Use a solid ground plane, and connect the ground-side of C_{IN} , C_{OUT} and the package GND as close as practical.

Mechanical Details

TQFN-16 Mechanical Specifications

The CM9133 is supplied in a 16-lead, 4.0mm x 4.0mm TQFN package. Dimensions are presented below.

For complete information on the TQFN16, see the California Micro Devices TQFN Package Information document.

PACKAGE DIMENSIONS						
Package	TQFN-16 (4x4)					
Leads	16					
Dim.	Millimeters			Inches		
	Min	Nom	Max	Min	Nom	Max
A		0.80	0.84		0.031	0.033
A1	0.00		0.04	0.00		0.002
A3	0.20 REF			.008		
b	0.25		0.33	0.010		0.013
D	4.0 BSC			0.157		
D1	1.95 REF			0.077		
D2	2.05		2.15	0.081		0.085
E	4.0 BSC			0.157		
E1	1.95 REF			0.077		
E2	2.05		2.15	0.081		0.085
e	0.65 TYP.			0.026		
L	0.55		0.65	0.022		0.026
# per tube	xx pieces*					
# per tape and reel	xxxx pieces					
Controlling dimension: millimeters						

* This is an approximate number which may vary.

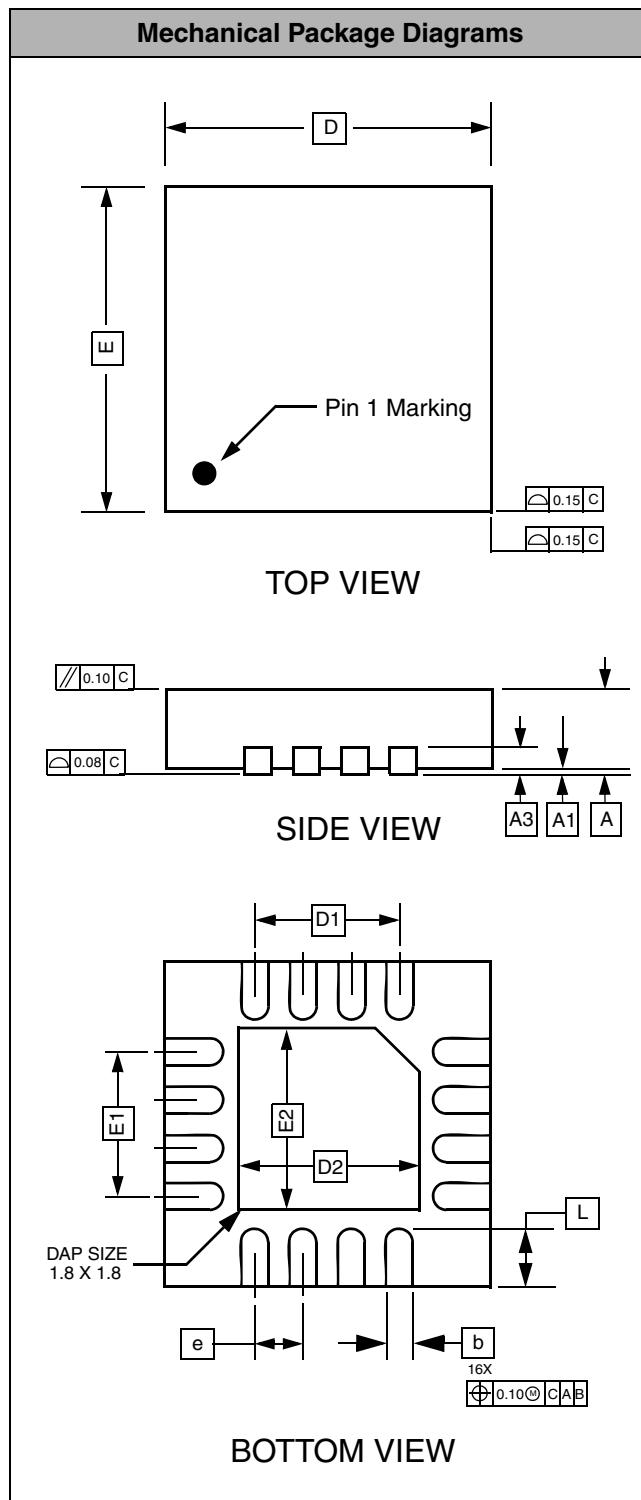

Package Dimensions for 16-Lead TQFN