



Advanced Analog Technology, Inc.

AAT1011A

3-CHANNEL PC POWER SUPPLY SUPERVISOR FOR 3.3V, 5V AND 12V

Features

- 3-Channel PC Power Supply Supervisor with Minimized External Components
- Over Voltage Protection for 3.3V / 5V / 12V Output
- Under Voltage Protection for 3.3V / 5V Output with 75 ms Enable Delay
- Fault Protection Output with Open Drain Output
- Open Drain Power Good Output
- 300 ms Power Good Delay
- 2.3 ms $\overline{\text{ONCTL}}$ to $\overline{\text{FPO}}$ Turn Off Delay
- 49 ms $\overline{\text{ONCTL}}$ Signal De-bounce
- 73 μs De-bounce
- Latch Function Controlled by $\overline{\text{ONCTL}}$ and Protection Input
- 8KV Highly Qualified ESD Protection

Pin Configuration

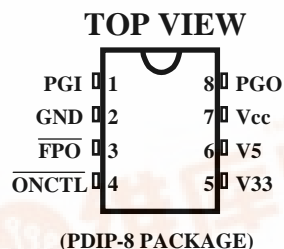

General Description

The AAT1011 is a 3-channel power supply supervisor with 8KV ESD protection. It provides Over Voltage Protection (OVP), Under Voltage Protection (UVP), and Power Good Indicator to monitor and control the output of the switching power supply system.

Remote function from external signal, *i.e.*, On/Off Control ($\overline{\text{ONCTL}}$), is also implemented.

Over voltage fault protection and under voltage fault protection can be directly triggered without external voltage divider.

With a minimum number of external components, the AAT1011 offers a simple and cost effective solution. Meanwhile, it can greatly reduce the PCB board space for power supply system.

*Spec is subject to change without notice in this document.



FPO (Fault Protection Output)

NORMAL="LOW", FAULT="HIGH"

FPO indicates the fault condition of either Over Voltage or Under Voltage. When a fault state occurs, the FPO latched high and combined with a low PGO output.

PGO (Power Good Output)

NORMAL="HIGH", FAULT="LOW".

The Power Good signal will be issued with 300 ms delay after 3.3V, 5V, 12V and PGI are ready. Power Good Output should be low before the output voltage is out of regulation at turn-off.

OVP and UVP

OVP monitors 3.3V, 5V, and 12V (via Vcc pin) UVP monitors 3.3V and 5V. OVP and UVP levels are determined by internal voltage dividers. The typical values are 3.9V, 6.1V, 13.8V for OVP and 2.83V, 4.3V for UVP, respectively.

$\overline{\text{ONCTL}}$ (On/Off Control)

On/Off Control is used to reset the latched state of $\overline{\text{FPO}}$ and to externally control the switching power supply system with a 49 ms de-bounce time. AAT1011 offers 2.3 ms delay time after de-bounce to trigger $\overline{\text{FPO}}$ when $\overline{\text{ONCTL}}$ switches from low to high

**Pin Description**

Pin #	Name	I/O	Description
1	PGI	I	Power Good Input signal
2	GND		Ground
3	$\overline{\text{FPO}}$	O	Inverted Fault Protection Output, open drain output stage
4	$\overline{\text{ONCTL}}$	I	ON/OFF control input
5	V33	I	Over and Under Voltage Protection for 3.3V
6	V5	I	Over and Under Voltage Protection for 5V
7	V _{CC}	I	Supply voltage and 12V over voltage protection input
8	PGO	O	Power Good Output signal, open drain output stage

Absolute Maximum Ratings

CHARACTERISTICS	SYMBOL	VALUE	UNIT
Supply voltage	V _{CC}	16	V
ESD voltage	V _{ESD}	8	KV
$\overline{\text{FPO}}$ output voltage	V _{FPO}	16	V
PGO output voltage	V _{PGO}	8	V
Supply Current	I _{CC}	1	mA
Operating free-air temperature range	T _{op}	-25 ~ 85	°C
Storage temperature range	T _{stg}	-65 ~ 125	°C

Recommended Operating Conditions

		Test Condition	Min	Typ	Max	Unit
Supply voltage, V _{CC}			4		15	V
Input voltage, V _I	$\overline{\text{ONCTL}}$, V5, V33, PGI				7	V
Output voltage	V _{FPO}				15	V
	V _{PGO}				7	V
Output sink current, I _O (sink)	I _{FPO}				30	mA
	I _{PGO}				10	mA
Supply voltage rising time, t _r		See Note 1	1			ms

Note 1: V_{CC} slew rate must be less than 14 V/ms.



Electrical Characteristics, $V_{CC} = 5\text{ V}$ (Unless Otherwise Specified)
Over Voltage Protection and Under Voltage Protection

Parameter		Test Condition	Min	Typ	Max	Unit
Over voltage threshold	V33		3.7	3.9	4.1	V
	V5		5.7	6.1	6.5	
	V_{CC}		13.3	13.8	14.3	
Under-voltage threshold	V33		2.71	2.83	2.95	V
	V 5		4.1	4.3	4.47	
	V_{CC}			3.8		

PGO and $\overline{\text{FPO}}$

Parameter		Test Condition	Min	Typ	Max	Unit
I_{LKG} Leakage current (PGO)		PGO = 5 V			5	μA
V_{OL} Low level output voltage (PGO)		$I_{sink} = 10\text{ mA}$			0.4	V
I_{LKG} Leakage current ($\overline{\text{FPO}}$)		$V(\overline{\text{FPO}}) = 5\text{ V}$			5	μA
V_{OL} Low level output voltage ($\overline{\text{FPO}}$)		$I_{sink} = 10\text{ mA}$			0.3	V
		$I_{sink} = 30\text{ mA}$			0.7	

PGI and $\overline{\text{ONCTL}}$

Parameter		Test Condition	Min	Typ	Max	Unit
Input threshold voltage (PGI)			1.141	1.192	1.242	V
Input pull-up current ($\overline{\text{ONCTL}}$)		$\overline{\text{ONCTL}} = 0\text{ V}$		150		μA
High-level input voltage ($\overline{\text{ONCTL}}$)			2.0			V
Low-level input voltage ($\overline{\text{ONCTL}}$)					0.8	V

Operating Current

Parameter		Test Condition	Min	Typ	Max	Unit
I_{CC} Supply current		$\overline{\text{ONCTL}} = 5\text{ V}$			1	mA

Switching Characteristics, $V_{CC} = 5\text{ V}$, $T_{op} = \text{Full Range}$

Parameter		Test Condition	Min	Typ	Max	Unit
t_{d1} PGO delay time			200	300	450	ms
t_{d2} Under Voltage Protection delay time			49	75	114	ms
t_{d3} $\overline{\text{ONCTL}}$ off to $\overline{\text{FPO}}$ delay time			tb1+1.1	tb1+2.3	tb1+4.4	ms
t_{b1} $\overline{\text{ONCTL}}$ de-bounce time			32.7	49	73.5	ms
t_{b2} Noise de-bounce time			47	73	110	μs



Function Block Diagram

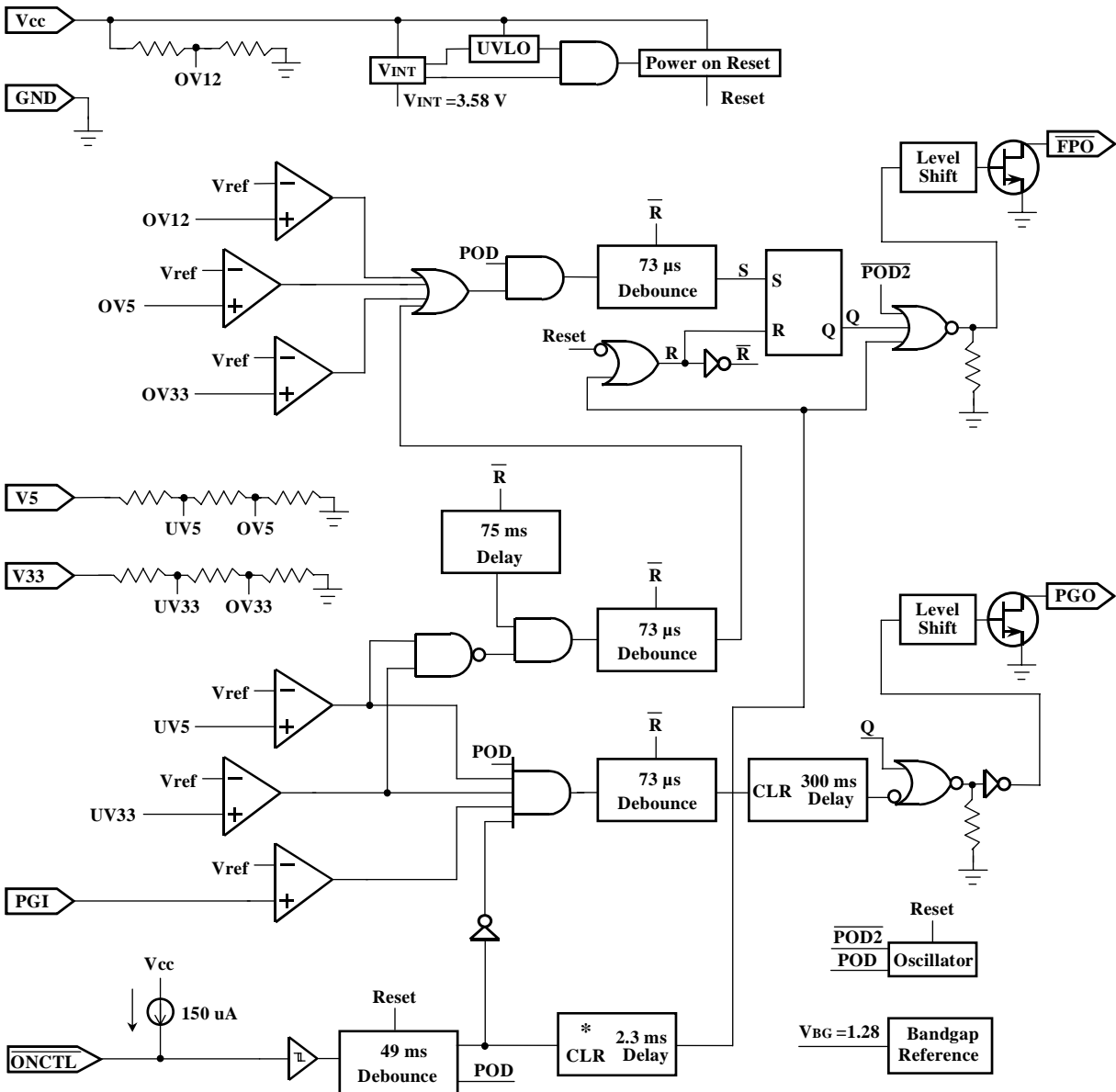



Timing Chart
AAT1011

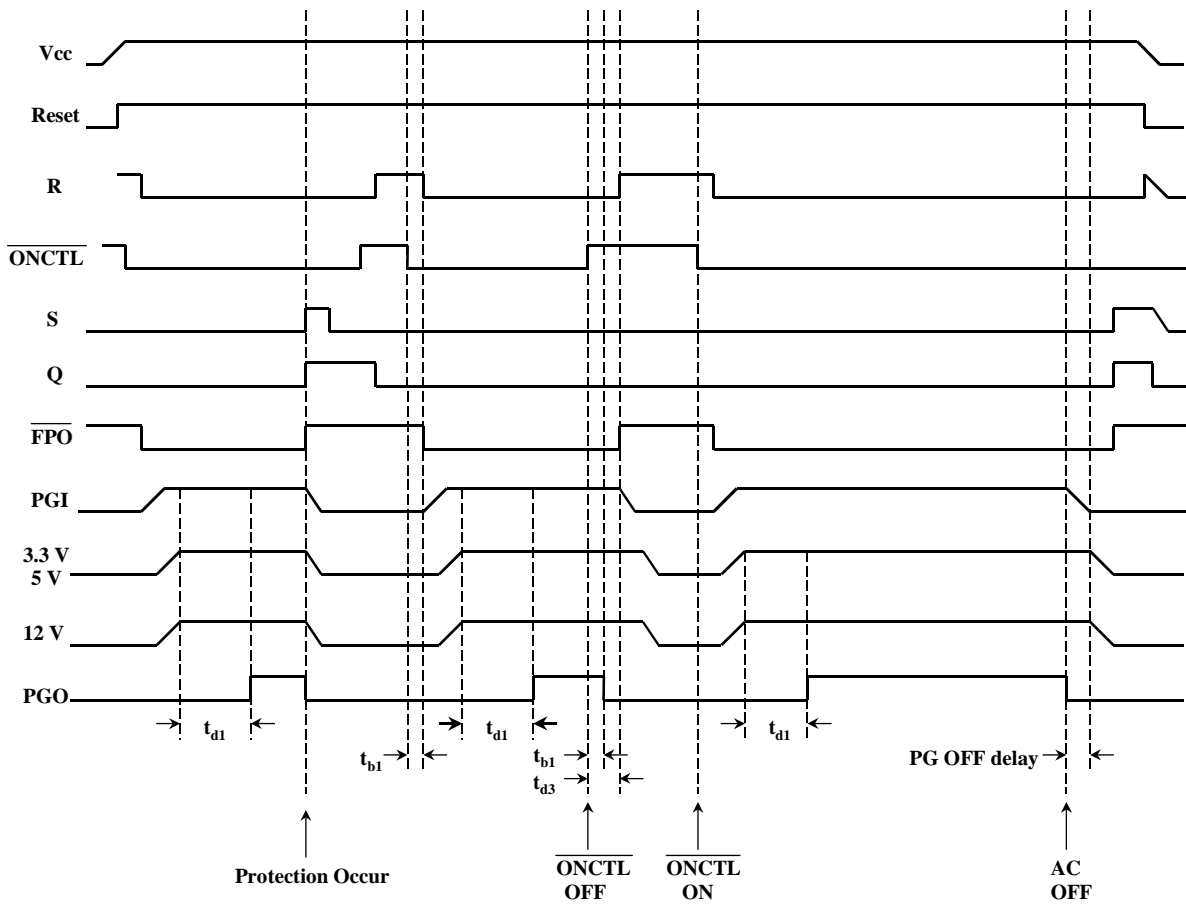



Package Dimension (Unit: Mil)

