



# AAT4285

## 12V Slew Rate Controlled Load Switch

SmartSwitch™

### General Description

The AAT4285 SmartSwitch is a P-channel MOSFET power switch designed for high-side load switching applications. The MOSFET operates from a 3.0V to 13.2V input range making it ideal for applications in single or dual cell Lithium-Ion battery systems. The device has a typical  $R_{DS(ON)}$  of 240m $\Omega$  at 12V, allowing a low forward voltage drop and high current handling capability. The device is a slew rate limited turn-on load switch and is functionally compatible with the AAT4250 and AAT4280 products, while offering a high operating voltage. The AAT4285 features fast load switch turn-on capability of 100 $\mu$ s and offers a shutdown load discharge circuit to rapidly turn off a load circuit when the switch is disabled. The quiescent supply current is very low, typically 25 $\mu$ A.

The AAT4285 is available in a Pb-free, 8-pin SC70JW package and is specified over the -40°C to +85°C temperature range.

### Features

- $V_{IN}$  Range: 3.0V to 13.2V
- Low  $R_{DS(ON)}$ 
  - 240m $\Omega$  typical @ 12V
  - 310m $\Omega$  Typical at 5V
- 100 $\mu$ s Slew Rate Turn-on Time
- Fast Shutdown Load Discharge
- Low Quiescent Current
  - Typically 25 $\mu$ A
  - 1 $\mu$ A Maximum in Shutdown
- TTL/CMOS Input Logic Level
- Temperature Range: -40°C to +85°C
- 8-pin SC70JW Package

### Applications

- 2 Cell Lithium-Ion Batteries
- Camcorders
- Handheld Test Equipment
- Load Switching

### Typical Application

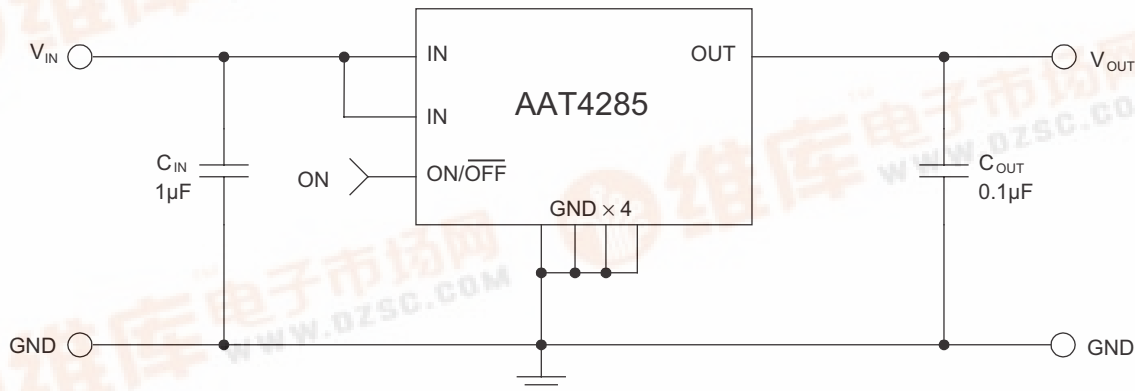

## Pin Descriptions

Pin #	Symbol	Function
1,2	IN	P-channel MOSFET source. Bypass to ground through a 1 $\mu$ F capacitor.
3	OUT	P-channel MOSFET drain connection. Bypass to ground through a 0.1 $\mu$ F capacitor.
4	ON/OFF	Active high enable input. A logic low turns the switch off and the device consumes less than 1 $\mu$ A of current. Logic high resumes normal operation.
5, 6, 7, 8	GND	Ground connection

## Pin Configuration

**SC70JW-8**  
(Top View)

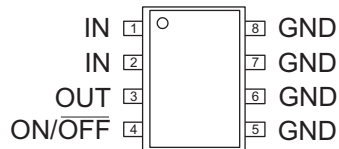

### Absolute Maximum Ratings<sup>1</sup>

Symbol	Description	Value	Units
$V_{IN}$	IN to GND	-0.3 to 14	V
$V_{ON}$	ON/OFF to GND	-0.3 to 14	V
$V_{OUT}$	OUT to GND	-0.3 to $V_{IN} + 0.3$	V
$I_{MAX}$	Maximum Continuous Switch Current	1.7	A
$I_{DM}$	Maximum Pulsed Current	3.4	A
$T_J$	Operating Junction Temperature Range	-40 to 150	°C

### Thermal Characteristics<sup>2</sup>

Symbol	Description	Value	Units
$\theta_{JA}$	Thermal Resistance	140	°C/W
$P_D$	Maximum Power Dissipation	714	mW

1. Stresses above those listed in Absolute Maximum Ratings may cause permanent damage to the device. Functional operation at conditions other than the operating conditions specified is not implied. Only one Absolute Maximum Rating should be applied at any one time.  
2. Mounted on an FR4 board.

### Electrical Characteristics<sup>1</sup>

$V_{IN} = 12V$ ,  $T_A = -40^{\circ}C$  to  $+85^{\circ}C$ , unless otherwise noted. Typical values are  $T_A = 25^{\circ}C$ .

Symbol	Description	Conditions	Min	Typ	Max	Units
$V_{IN}$	Operation Voltage		3.0		13.2	V
$V_{UVLO}$	Under-Voltage Lockout			2.7	3.0	V
$V_{UVLO(hys)}$	Under-Voltage Lockout Hysteresis			250		V
$I_Q$	Quiescent Current	ON/OFF = Active, $I_{OUT} = 0$		25	50	$\mu A$
$I_{Q(OFF)}$	Off Supply Current	ON/OFF = Inactive, OUT = Open			1.0	$\mu A$
$I_{SHD}$	Off Switch Current	ON/OFF = GND, $V_{OUT} = 0$		0.1	1.0	$\mu A$
$R_{DS(ON)}$	On Resistance	$V_{IN} = 12V$		240	400	m $\Omega$
		$V_{IN} = 5V$		310	500	
		$V_{IN} = 3.3V$		380		
$TCR_{RDS}$	On Resistance Temperature Coefficient			2800		ppm/ $^{\circ}C$
$T_{D(ON)}$	Output Turn-On Delay Time <sup>2</sup>	$R_{LOAD} = 20\Omega$ , $T_A = 25^{\circ}C$		20	40	$\mu s$
$T_{ON}$	Turn-On Rise Time <sup>2</sup>	$R_{LOAD} = 20\Omega$ , $T_A = 25^{\circ}C$		100	250	$\mu s$
$T_{D(OFF)}$	Output Turn-Off Delay Time <sup>2</sup>	$R_{LOAD} = 20\Omega$ , $T_A = 25^{\circ}C$		1	10	$\mu s$
$R_{PD}$	Output Pull-Down Resistance During OFF	ON/OFF Inactive, $T_A = 25^{\circ}C$		520	800	$\Omega$
$V_{ON(L)}$	ON/OFF Input Logic Low Voltage	$V_{IN} = 3V$ to $13V$			0.4	V
$V_{ON(H)}$	ON/OFF Input Logic High Voltage	$V_{IN} = 3V$ to $13V$	1.6			V
$I_{ON}$	ON/OFF Leakage Current	$V_{ON/OFF} = 13V$	-1.0		1.0	$\mu A$

1. The AAT4285 is guaranteed to meet performance specifications over the  $-40^{\circ}C$  to  $+85^{\circ}C$  operating temperature range and is assured by design, characterization, and correlation with statistical process controls.  
 2. Contact factory for other turn-on and delay options.

### Typical Characteristics

Quiescent Current vs. Temperature

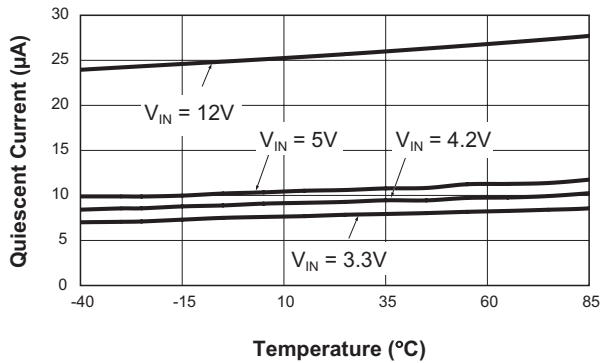

Quiescent Current vs. Input Voltage

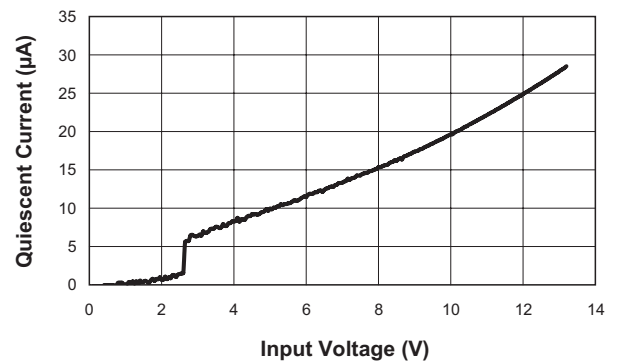

$R_{DS(ON)}$  vs. Temperature

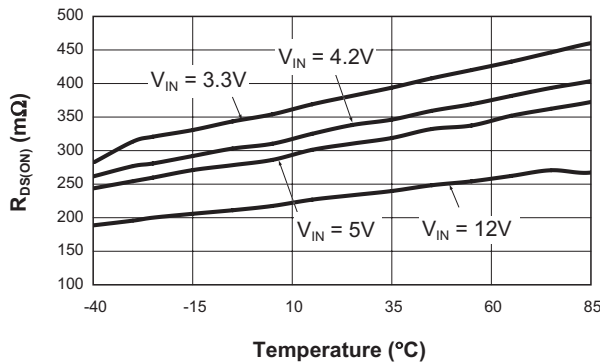

$R_{DS(ON)}$  vs. Input Voltage

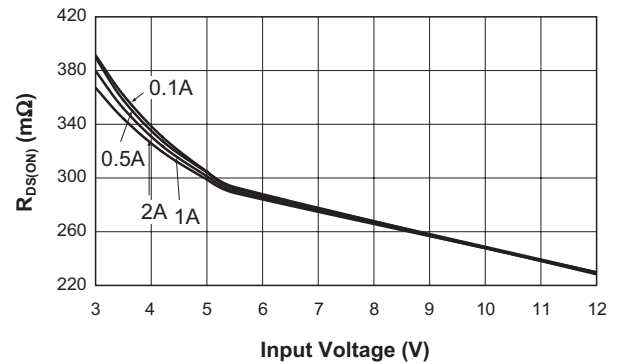

ON/OFF Threshold Low vs. Input Voltage

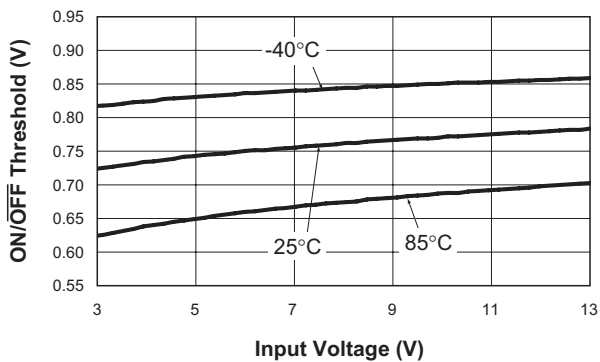

ON/OFF Threshold High vs. Input Voltage

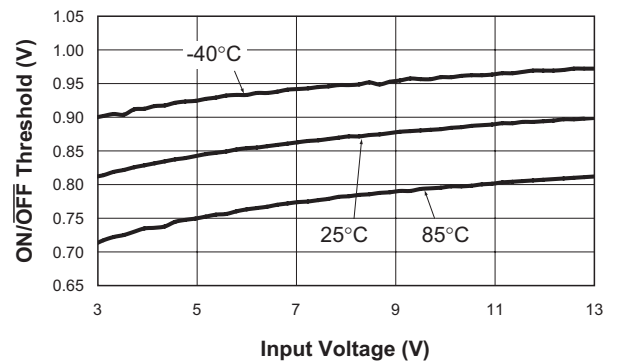

### Typical Characteristics

**Output Pull-Down Resistance vs. Temperature**

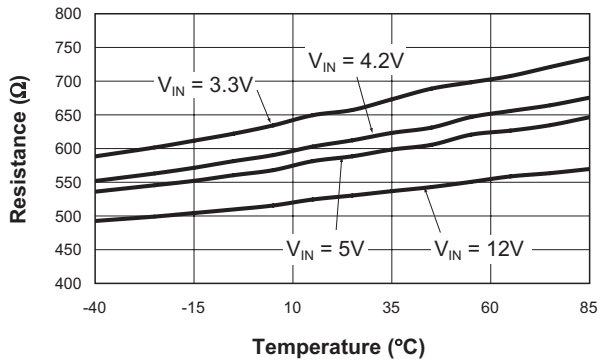

**Turn-On**  
( $V_{IN} = 12\text{V}$ ; 600mA Load)

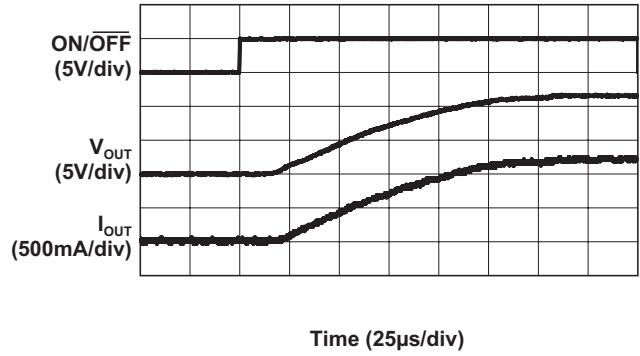

**Turn-Off**  
( $V_{IN} = 12\text{V}$ ; 600mA Load)

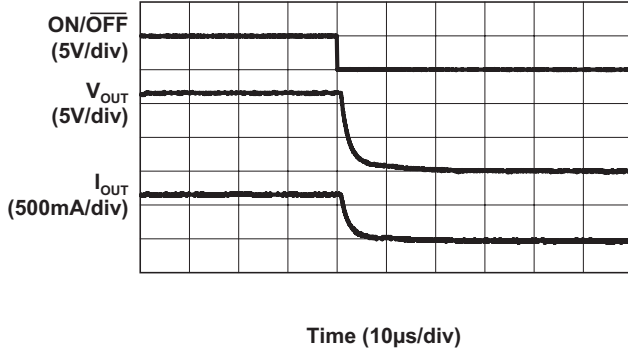

### Functional Block Diagram

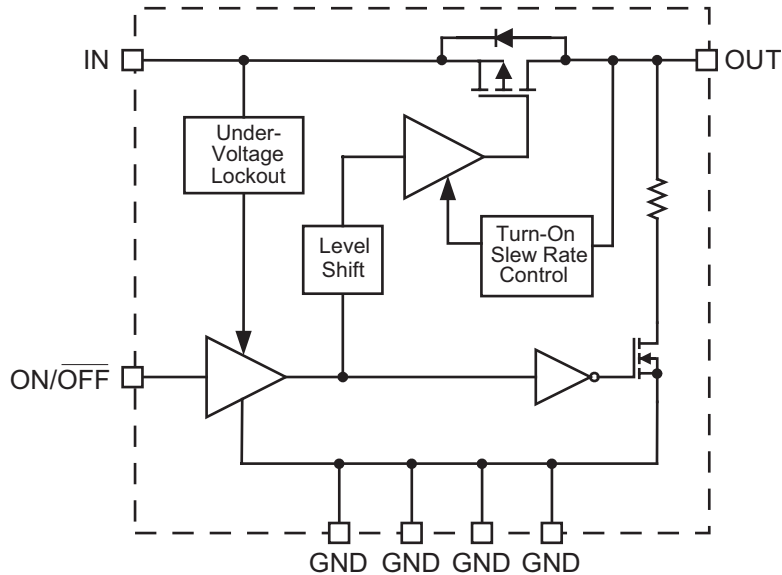

### Functional Description

The AAT4285 is a slew rate controlled P-channel MOSFET power switch designed for high-side load switching applications. The device operates with input voltages ranging from 3.0V to 13.2V, making it ideal for single- or multi-cell battery-powered applications. In cases where the input voltage drops below 3.0V, the AAT4285 MOSFET is protected from entering the saturated region of operation by automatically shutting down. In addition, the TTL compatible ON/OFF pin makes the AAT4285 an ideal level-shifted load switch. The slew rate controlling feature eliminates inrush current when

the MOSFET is turned on, allowing the AAT4285 to operate with a small input capacitor, or no input capacitor at all. During slewing, the current ramps linearly until it reaches the level required for the output load condition. The proprietary control method works by careful control and monitoring of the MOSFET gate voltage. When the device is switched ON, the gate voltage is quickly increased to the threshold level of the MOSFET. Once at this level, the current begins to slew as the gate voltage is slowly increased until the MOSFET becomes fully enhanced. Once it has reached this point, the gate is quickly increased to the full input voltage and  $R_{DS(ON)}$  is minimized.

## Applications Information

### Input Capacitor

A 1 $\mu$ F or larger capacitor is typically recommended for  $C_{IN}$  in most applications. A  $C_{IN}$  capacitor is not required for basic operation. However,  $C_{IN}$  is useful in preventing load transients from affecting upstream circuits.  $C_{IN}$  should be located as close to the device  $V_{IN}$  pin as practically possible.

Ceramic, tantalum, or aluminum electrolytic capacitors may be selected for  $C_{IN}$ . There is no specific capacitor ESR requirement for  $C_{IN}$ . However, for higher current operation, ceramic capacitors are recommended for  $C_{IN}$  due to their inherent capability over tantalum capacitors to withstand input current surges from low impedance sources, such as batteries in portable devices.

### Output Capacitor

For proper slew operation, a 0.1 $\mu$ F capacitor or greater between OUT and GND is recommended.

The output capacitor has no specific capacitor type or ESR requirement. If desired,  $C_{OUT}$  may be increased without limit to accommodate any load transient condition without adversely affecting the device turn-on slew rate time.

### Enable Function

The AAT4285 features an enable / disable function. This pin ( $\overline{ON/OFF}$ ) is compatible with both TTL and CMOS logic.

### Reverse Output-to-Input Voltage Conditions and Protection

Under normal operating conditions, a parasitic diode exists between the output and input of the load switch. The input voltage should always remain greater than the output load voltage, maintaining a reverse bias on the internal parasitic diode. Conditions where  $V_{OUT}$  might exceed  $V_{IN}$  should be avoided since this would forward bias the internal parasitic diode and allow excessive current flow into the OUT pin and possibly damage the load switch.

In applications where there is a possibility of  $V_{OUT}$  exceeding  $V_{IN}$  for brief periods of time during normal operation, the use of a larger value  $C_{IN}$  capacitor

is highly recommended. A larger value of  $C_{IN}$  with respect to  $C_{OUT}$  will affect a slower  $C_{IN}$  decay rate during shutdown, thus preventing  $V_{OUT}$  from exceeding  $V_{IN}$ . In applications where there is a greater danger of  $V_{OUT}$  exceeding  $V_{IN}$  for extended periods of time, it is recommended to place a Schottky diode from IN to OUT (connecting the cathode to IN and anode to OUT). The Schottky diode forward voltage should be less than 0.45V.

### Thermal Considerations and High Output Current Applications

The AAT4285 is designed to deliver a continuous output load current. The limiting characteristic for maximum safe operating output load current is package power dissipation. In order to obtain high operating currents, careful device layout and circuit operating conditions need to be taken into account.

The following discussions will assume the load switch is mounted on a printed circuit board utilizing the minimum recommended footprint, as stated in the Layout Considerations section of this datasheet.

At any given ambient temperature ( $T_A$ ), the maximum package power dissipation can be determined by the following equation:

$$P_{D(MAX)} = \frac{T_{J(MAX)} - T_A}{\theta_{JA}}$$

Constants for the AAT4285 are maximum junction temperature,  $T_{J(MAX)} = 125^\circ\text{C}$ , and package thermal resistance,  $\theta_{JA} = 140^\circ\text{C/W}$ . Worst case conditions are calculated at the maximum operating temperature where  $T_A = 85^\circ\text{C}$ . Typical conditions are calculated under normal ambient conditions where  $T_A = 25^\circ\text{C}$ . At  $T_A = 85^\circ\text{C}$ ,  $P_{D(MAX)} = 286\text{mW}$ . At  $T_A = 25^\circ\text{C}$ ,  $P_{D(MAX)} = 714\text{mW}$ .

The maximum continuous output current for the AAT4285 is a function of the package power dissipation and the  $R_{DS}$  of the MOSFET at  $T_{J(MAX)}$ . The maximum  $R_{DS}$  of the MOSFET at  $T_{J(MAX)}$  is calculated by increasing the maximum room temperature  $R_{DS}$  by the  $R_{DS}$  temperature coefficient. The temperature coefficient ( $\text{TCR}_{RDS}$ ) is 2800ppm/ $^\circ\text{C}$ . Therefore,

$$\begin{aligned} \text{MAX } R_{DS} 125^\circ\text{C} &= R_{DS} 25^\circ\text{C} \cdot (1 + \text{TCR}_{RDS} \cdot \Delta T) \\ \text{MAX } R_{DS} 125^\circ\text{C} &= 240\text{m}\Omega \cdot (1 + 0.0028 \cdot (125^\circ\text{C} - 25^\circ\text{C})) \\ &= 307\text{m}\Omega \end{aligned}$$



For maximum current, refer to the following equation:

$$I_{OUT(MAX)} < \sqrt{\frac{P_{D(MAX)}}{R_{DS}}}$$

For example, if  $V_{IN} = 12V$ ,  $R_{DS(MAX)} = 307m\Omega$  and  $T_A = 25^\circ C$ ,  $I_{OUT(MAX)} = 1.53A$ . If the output load current were to exceed 1.53A or if the ambient temperature were to increase, the internal die temperature would increase, and the device would be damaged. Higher peak currents can be obtained with the AAT4285. To accomplish this, the device thermal resistance must be reduced by increasing the heat sink area or by operating the load switch in a duty cycled manner.

### High Peak Output Current Applications

Some applications require the load switch to operate at a continuous nominal current level with short duration, high-current peaks. The duty cycle for both output current levels must be taken into account. To do so, first calculate the power dissipation at the nominal continuous current level, and then add in the additional power dissipation due to the short duration, high-current peak scaled by the duty factor.

For example, a 12V system using an AAT4285 operates at a continuous 100mA load current level and has short 2A current peaks.

The current peak occurs for 500 $\mu$ s out of a 5ms period.

First, the current duty cycle is calculated:

$$\% \text{ Peak Duty Cycle} = \left( \frac{x}{100} \right) = \left( \frac{500\mu s}{5.0ms} \right)$$

$$\% \text{ Peak Duty Cycle} = 10\%$$

The load current is 100mA for 90% of the 5ms period and 2A for 10% of the period.

De-rated for temperature:

$$240m\Omega \cdot (1 + 0.0028 \cdot (125^\circ C - 25^\circ C)) = 307m\Omega$$

The power dissipation for a 100mA load is calculated as follows:

$$\begin{aligned} P_{D(MAX)} &= I_{OUT}^2 \cdot R_{DS} \\ P_{D(100mA)} &= (100mA)^2 \cdot 307m\Omega \\ P_{D(100mA)} &= 3.07mW \\ P_{D(90\%D/C)} &= \%DC \cdot P_{D(100mA)} \\ P_{D(90\%D/C)} &= 0.90 \cdot 3.07mW \\ P_{D(90\%D/C)} &= 2.76mW \end{aligned}$$

The power dissipation for 100mA load at 90% duty cycle is 2.76mW. Now the power dissipation for the remaining 10% of the duty cycle at 2A is calculated:

$$\begin{aligned} P_{D(MAX)} &= I_{OUT}^2 \cdot R_{DS} \\ P_{D(2A)} &= (2A)^2 \cdot 307m\Omega \\ P_{D(2A)} &= 1.23W \\ P_{D(10\%D/C)} &= \%DC \cdot P_{D(2A)} \\ P_{D(10\%D/C)} &= 0.10 \cdot 1.23mW \\ P_{D(10\%D/C)} &= 123mW \end{aligned}$$

The power dissipation for 2A load at 10% duty cycle is 123mW. Finally, the two power figures are summed to determine the total true power dissipation under the varied load.

$$\begin{aligned} P_{D(TOTAL)} &= P_{D(100mA)} + P_{D(2A)} \\ P_{D(TOTAL)} &= 2.76mW + 123mW \\ P_{D(TOTAL)} &= 125.76mW \end{aligned}$$

The maximum power dissipation for the AAT4285 operating at an ambient temperature of 85 $^\circ$ C is 286mW. The device in this example will have a total power dissipation of 123mW. This is well within the thermal limits for safe operation of the device; in fact, at 85 $^\circ$ C, the AAT4285 will handle a 2A pulse for up to 23% duty cycle. At lower ambient temperatures, the duty cycle can be further increased.

### Printed Circuit Board Layout Recommendations

For proper thermal management and to take advantage of the low  $R_{DS(ON)}$  of the AAT4285, a few circuit board layout rules should be followed:  $V_{IN}$

and  $V_{OUT}$  should be routed using wider than normal traces, and GND should be connected to a ground plane. To maximize package thermal dissipation and power handling capacity of the AAT4285 SC70JW-8 package, the ground plane area connected to the ground pins should be made as large as possible. For best performance,  $C_{IN}$  and  $C_{OUT}$  should be placed close to the package pins.

### Evaluation Board Layout

The AAT4285 evaluation board layout follows the printed circuit board layout recommendations and can be used for good application guide. Refer to Figures 1 through 3.

Note: Board layout shown is not to scale.

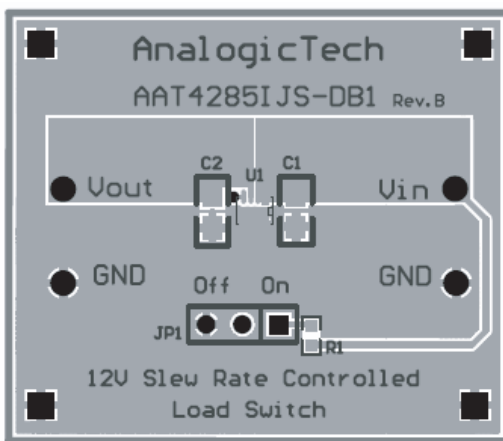

Figure 1: AAT4285 Evaluation Board Component Side Layout and Silk Screen.

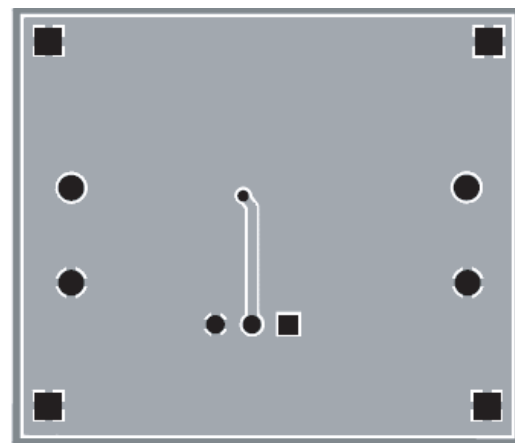
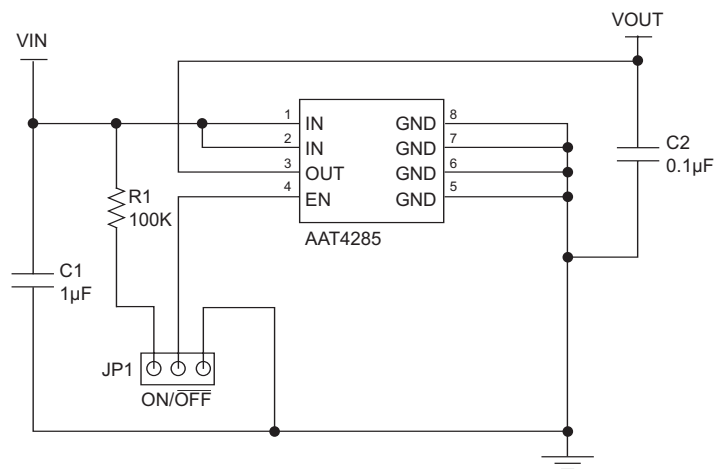

Figure 2: AAT4285 Evaluation Board Solder Side Layout.



C1 1µF X7R 16V 0805 GRM21BR71C105KA01  
(C1 1µF X5R 16V 0603 GRM188R61C105KA93)

C2 0.1µF X5R 16V 0805 GRM219R71C104KA01  
(C2 0.1µF X7R 16V 0603 GRM188R71C104KA01)

Figure 3: AAT4285 Evaluation Board Circuit Schematic Diagram.

### Ordering Information

Package	Marking <sup>1</sup>	Part Number (Tape and Reel) <sup>2</sup>
SC70JW-8	UAXYY	AAT4285IJS-3-T1



All AnalogicTech products are offered in Pb-free packaging. The term “Pb-free” means semiconductor products that are in compliance with current RoHS standards, including the requirement that lead not exceed 0.1% by weight in homogeneous materials. For more information, please visit our website at <http://www.analogictech.com/pbfree>.

### Package Information

#### SC70JW-8

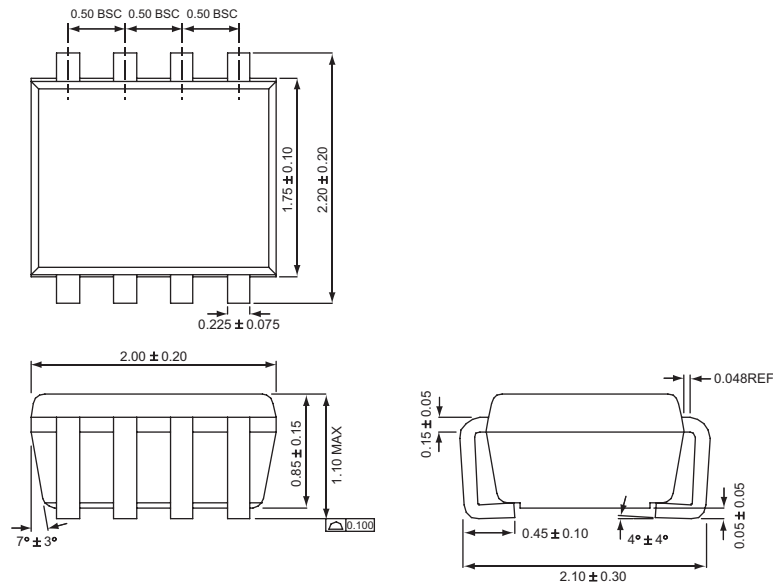

All dimensions in millimeters.

1. XYY = assembly and date code.
2. Sample stock is generally held on part numbers listed in **BOLD**.

© Advanced Analogic Technologies, Inc.

AnalogicTech cannot assume responsibility for use of any circuitry other than circuitry entirely embodied in an AnalogicTech product. No circuit patent licenses, copyrights, mask work rights, or other intellectual property rights are implied. AnalogicTech reserves the right to make changes to their products or specifications or to discontinue any product or service without notice. Except as provided in AnalogicTech's terms and conditions of sale, AnalogicTech assumes no liability whatsoever, and AnalogicTech disclaims any express or implied warranty relating to the sale and/or use of AnalogicTech products including liability or warranties relating to fitness for a particular purpose, merchantability, or infringement of any patent, copyright or other intellectual property right. In order to minimize risks associated with the customer's applications, adequate design and operating safeguards must be provided by the customer to minimize inherent or procedural hazards. Testing and other quality control techniques are utilized to the extent AnalogicTech deems necessary to support this warranty. Specific testing of all parameters of each device is not necessarily performed. AnalogicTech and the AnalogicTech logo are trademarks of Advanced Analogic Technologies Incorporated. All other brand and product names appearing in this document are registered trademarks or trademarks of their respective holders.

**Advanced Analogic Technologies, Inc.**  
 830 E. Arques Avenue, Sunnyvale, CA 94085  
 Phone (408) 737-4600  
 Fax (408) 737-4611