



Advanced Analog Technology, Inc.

AAT7203

Details are subject to change without notice

## 4+1-CHANNEL BUFFER FOR TFT LCD

### FEATURES

- 4+1-Channel:  
4 Channels with an Output Current of  $\pm 30\text{mA}$  (MAX); 1  $V_{\text{com}}$  with an Output Current of  $\pm 100\text{mA}$  (MAX)
- Unity Gain Buffer Capable of Driving Large Capacitive Loads
- Input Range Matched to LCD Reference Requirements
- $V_{\text{DD}}$  Specified for 6.5V to 16V
- TSSOP14 Package

### GENERAL DESCRIPTION

The AAT7203 is a 4+1-channel buffer designed for thin film transistor liquid crystal display (TFT LCD). This device consists of a  $V_{\text{com}}$  buffer circuit, two rail-to-rail buffer amplifier circuits, and 2 buffer amplifier circuits. Each buffer is capable of driving heavy capacitive loads and providing fast load current ( $V_{\text{com}}$  : 100mA, and the others: 30mA).

AAT7203 comes in a compact TSSOP14 package, which makes it an ideal component for space-sensitive designs of LCD monitors and LCD TVs.

### PIN CONFIGURATION

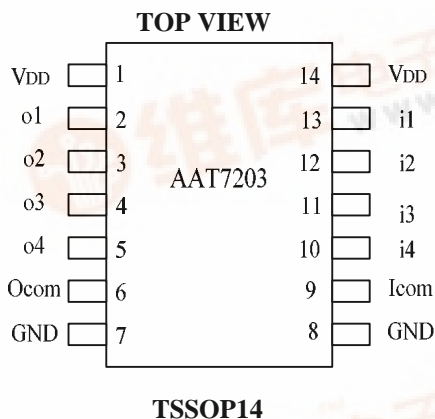

**PIN DESCRIPTION**

PIN NO.	NAME	I/O	DESCRIPTION
1	V <sub>DD</sub>	I	Power Supply
2	o1	O	Buffer Channel 1 Output
3	o2	O	Buffer Channel 2 Output
4	o3	O	Buffer Channel 3 Output
5	o4	O	Buffer Channel 4 Output
6	O <sub>com</sub>	O	Com Buffer Output
7	GND	I	Ground
8	GND	I	Ground
9	I <sub>com</sub>	I	Com Buffer Input
10	i4	I	Buffer Channel 4 Input
11	i3	I	Buffer Channel 3 Input
12	i2	I	Buffer Channel 2 Input
13	i1	I	Buffer Channel 1 Input
14	V <sub>DD</sub>	I	Power Supply

**ABSOLUTE MAXIMUM RATINGS**

CHARACTERISTICS	SYMBOL	VALUE	UNIT
Supply Voltage	V <sub>DD</sub>	+18	V
Input Voltage	V <sub>I</sub>	-0.5 to V <sub>DD</sub> + 0.5	V
Output Voltage	V <sub>O</sub>	-0.5 to V <sub>DD</sub> + 0.5	V
Output Loading Current for Gamma, Rail-to-Rail Buffer	I <sub>L</sub>	± 30	mA
Output Loading Current for Com Buffer		± 100	mA
Maximum Junction Temperature	T <sub>J</sub>	+125	°C
Operating Temperature	T <sub>C</sub>	- 20 to +85	°C
Storage Temperature	T <sub>storage</sub>	- 45 to +125	°C
Lead Temperature (Soldering for 10 Seconds)	---	260	°C

Note: Values beyond absolute maximum ratings may cause permanent damage to the device.



**ELECTRICAL CHARACTERISTICS ( $V_{DD}=10V$ ,  $T_C=25^{\circ}C$  UNLESS OTHERWISE SPECIFIED)**

**POWER SUPPLY PERFORMANCE**

PARAMETER		TEST CONDITIONS	MIN	TYP	MAX	UNITS
Power Supply Rejection Ratio	PSRR	$V_{DD}$ varies from 6.5V to 16.0V	-	80	-	dB
Supply Current	$I_S$		-	6.3	-	mA

**INPUT CHARACTERISTICS**

PARAMETER		TEST CONDITIONS	MIN	TYP	MAX	UNITS
Input Offset Voltage	$V_{OS}$	$V_I = V_{DD}/2$ , $V_O = V_{DD}/2$	-	2	12	mV
Input Bias Current	$I_B$	$V_I = V_{DD}/2$ , $V_O = V_{DD}/2$	-	2	50	nA

Note 2: Slew rate is measured on rising and falling edges.



**ELECTRICAL CHARACTERISTICS ( $V_{DD}=10V$ ,  $T_C=25^{\circ}C$  UNLESS OTHERWISE SPECIFIED)**

**OUTPUT CHARACTERISTICS**

PARAMETER		TEST CONDITIONS	MIN	TYP	MAX	UNITS
Output Swing Low	$V_{OL}$	$I_L=5mA$ (Buffer 1, 4) $V_I=0V$	-	0.08	0.15	V
		$I_L=10mA$ (Buffer 2, 3) $V_I=1V$	-	1.02	1.05	V
Output Swing High	$V_{OH}$	$I_L=-5mA$ (Buffer 1, 4) $V_I=10V$	9.85	9.92	-	V
		$I_L=-10mA$ (Buffer 2, 3) $V_I=9V$	8.95	8.98	-	V
Output Swing (Buffer 2,3)	$V_{OL}$	$I_L=10mA$ , $V_I=5V$	-	5.02	5.04	V
	$V_{OH}$	$I_L=-10mA$ , $V_I=5V$	4.96	4.98	-	V
Output Swing (COM)	$V_{OL}$	$I_L=50mA$ , $V_I=5V$	-	5.03	5.05	V
	$V_{OH}$	$I_L=-50mA$ , $V_I=5V$	4.95	4.97	-	V
Short Circuit Current	$I_{SC}$	(Buffer 2,3 )	-	$\pm 70$	-	mA
		(Com Buffer, Buffer 1, 4)	-	$\pm 180$	-	mA

**AC CHARACTERISTICS**

Parameter		Test Conditions	Min	Typ	Max	Units
Slew Rate (Note 2)	SR	$V_I=2V$ to $8V$ , 20% to 80%	-	1	-	V/ $\mu s$
Settling Time	$t_s$	$V_I=4.5V$ to $5.5V$ 0.1%	-	5	-	$\mu s$
		$V_I=5.5V$ to $4.5V$ 0.1%				

Note 2: Slew rate is measured on rising and falling edges.



**BLOCK DIAGRAM**

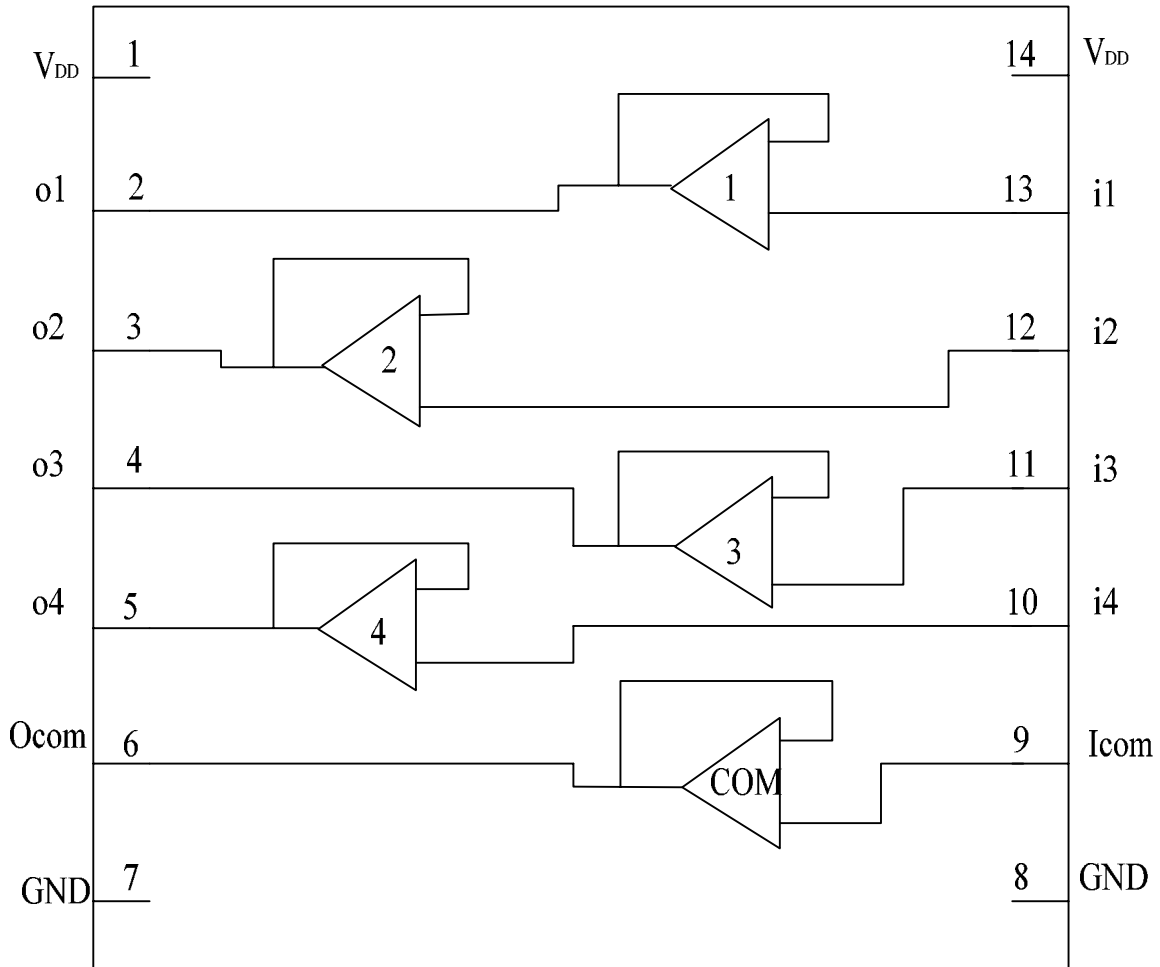



APPLICATION CIRCUIT

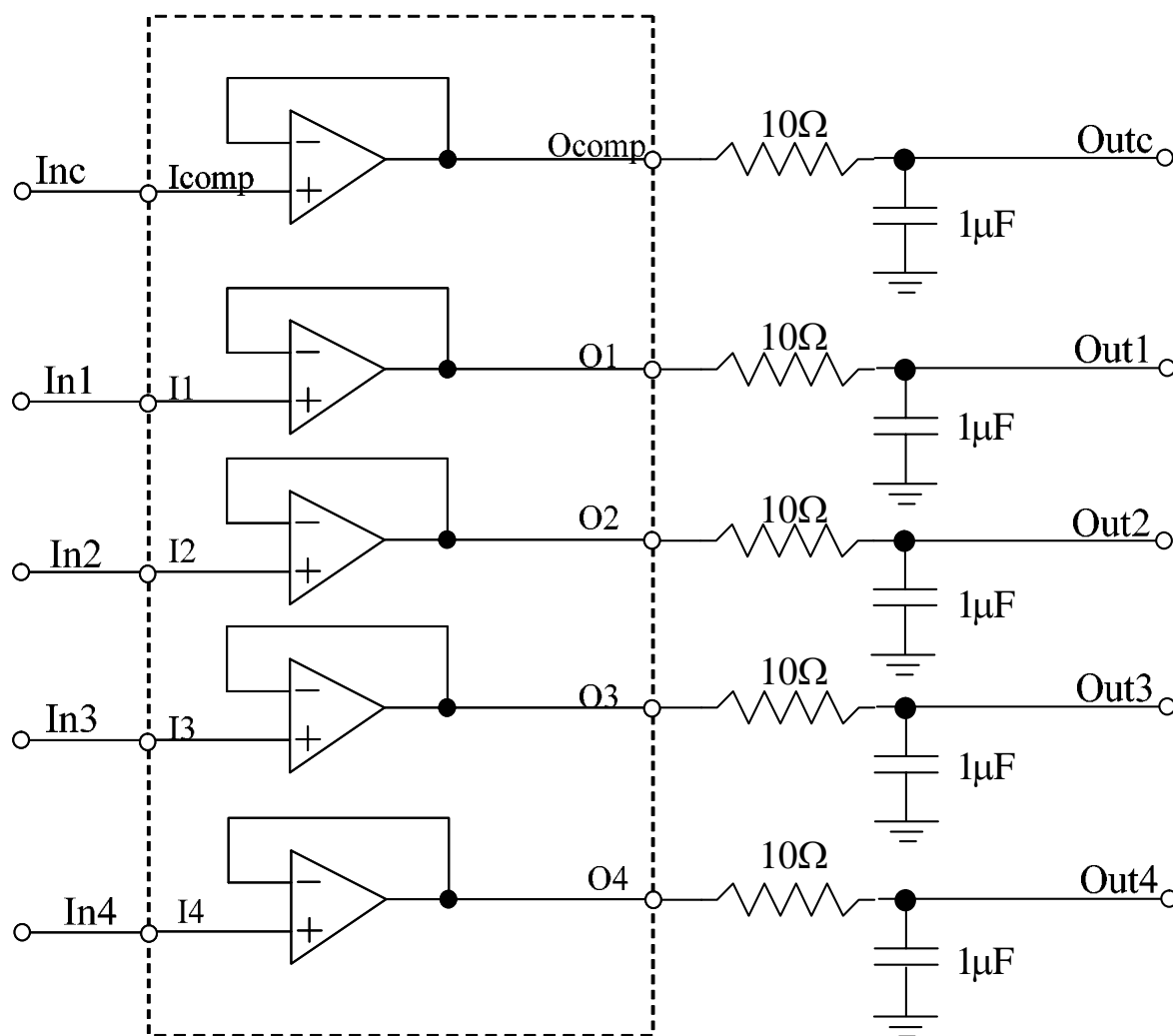



**PACKAGE DIMENSION**  
**TSSOP14**

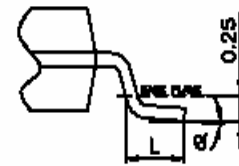
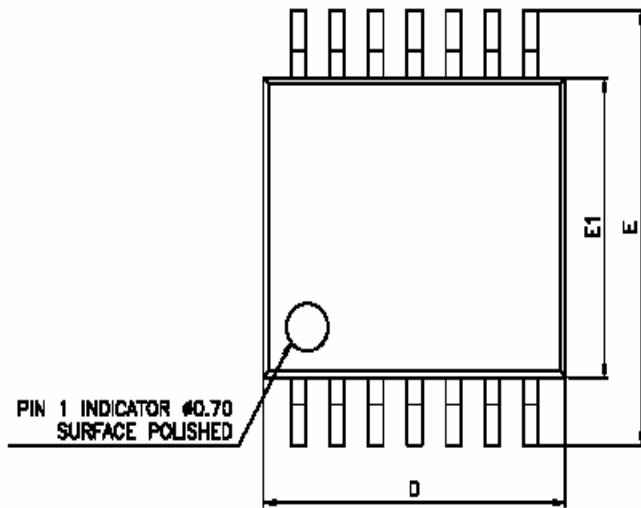

DETAIL A

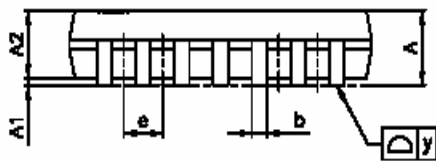

**PACKAGE DIMENSION (CONT.)  
TSSOP14**

SYMBOL	DIMENSIONS IN MILLIMETERS			DIMENSIONS IN INCHES		
	MIN	TYP	MAX	MIN	TYP	MAX
A	---	---	1.20	---	---	0.047
A1	0.05	---	0.15	0.002	---	0.006
A2	0.80	1.00	1.05	0.031	0.039	0.041
b	0.19	---	0.30	0.007	---	0.012
C	0.09	---	0.20	0.0035	---	0.0080
D	4.90	5.00	5.10	0.193	0.197	0.201
E	---	6.40	---	0.193	0.252	0.201
E1	4.30	4.40	4.50	0.170	0.173	0.177
e	---	0.65	---	---	0.026	---
L	0.45	0.60	0.75	0.0177	0.0240	0.0295
y	---	---	0.076	---	---	0.003
θ	0°	---	8°	0°	---	8°

## Note:

1. CONTROLLING DIMENSION: MILLIMETERS
2. LEAD FRAME MATERIAL: OLIN C7025/EFTEC 64T
3. DIMENSION "D" DOES NOT INCLUDE MOLD FLASH, TIE BAR BURRS AND GATE BURRS. MOLD FLASH, TIE BAR BURRS AND GATE BURRS SHALL NOT EXCEED 0.006" [0.15 MILLIMETERS] PER END. DIMENSION "E1" DOES NOT INCLUDE INTERLEAD FLASH. INTERLEAD FLASH SHALL NOT EXCEED 0.010" [0.25 MILLIMETERS] PER SIDE.
4. DIMENSION "b" DOES NOT INCLUDE DAMBAR PROTRUSION. ALLOWABLE DAMBAR PROTRUSION SHALL BE 0.003" [0.08 MILLIMETERS] TOTAL IN EXCESS OF THE "b" DIMENSION AT MAXIMUM MATERIAL CONDITION. DAMBAR CANNOT BE LOCATED ON THE LOWER RADIUS OR THE FOOT. MINIMUM SPACE BETWEEN PROTRUSION AND AN ADJACENT LEAD TO BE 0.0028" [0.07 MILLIMETERS]
5. TOLERANCE: ± 0.010" [0.25 MILLIMETERS] UNLESS OTHERWISE SPECIFIED.
6. OTHERWISE DIMENSION FOLLOW ACCEPTABLE SPEC.
7. REFERENCE DOCUMENT: JEDEC SPEC MO-153





**ORDERING INFORMATION**

**AAT xxxxx-xx-x**

AAT Part Number

Package Code 1  
Tssop14: T5

Package Code 2  
T=Taping Reel  
Blank=Tube or Tray

**Remark:**  
**T=Taping Reel**

**Blank=Tube**